

SUNBA[®]

Dedicated PTZ Camera Professional

2021/06
Version 4.1

SUNBA[®] PTZ Camera Analog Series

User Manual

Version 4.1

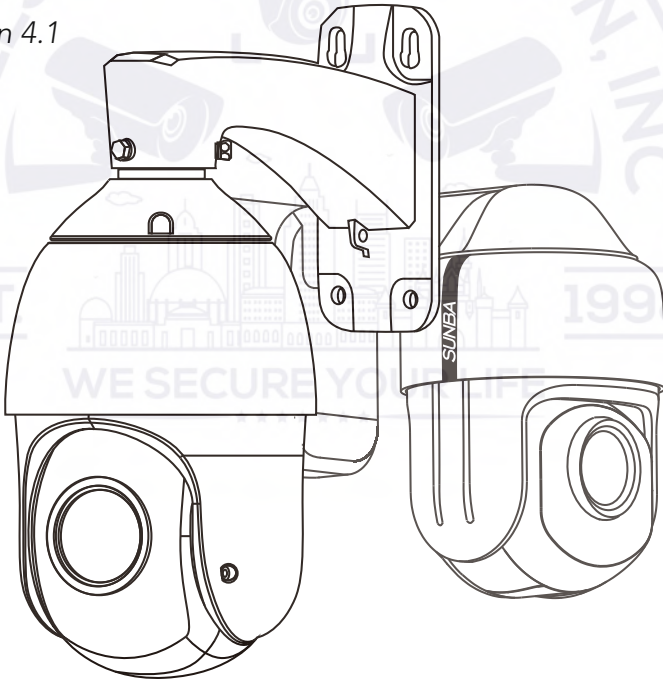

FCC Warning (U.S.A)

The device has been tested in compliance with limits set by Part 15 of Federal Communication Commission (Class B). The operation of the device is thus limited by the following two conditions:

1) it is not permitted to cause harmful interference to any authorized radio communications, and 2) it must accept any interference it receives.



WARNING: Please test the camera locally by directly connecting to the default power adapter from the package before mounting it outside. Stay at least 24 hours to test both daytime and night vision IR LED.

1. Camera Compatibility



Analog cameras require a decoder to display images on a monitor. Sunba Analog PTZ camera requires Pelco D protocol and RS485 standard to support PTZ.

A decoder can be a DVR or a video capture card. Some TV (with built-in decoder) also supports CVBS signal.

Sunba Analog Cameras: 960H CVBS Signal
Model: 305-A4X, 301-3X, 405-22X, 405-36X

Common Decoding Equipment

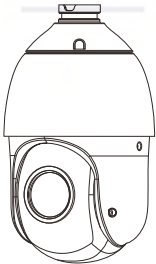

Type A: 960H Digital Video Recorder (DVR)

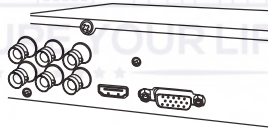

Type B: CCTV Monitor with Built-in CVBS decoder



This enables your camera to properly display videos.

Common RS485 Control Equip-

Type A: Digital Video Recorder (DVR) with RS485 Port

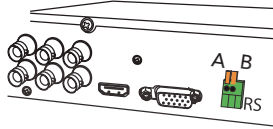
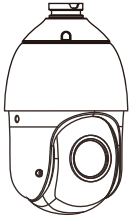

Type B: 3D Pan Tilt Zoom Joystick (usually used with DVR without RS485 port or with CCTV monitor)



This enables your camera to pan tilt zoom.



Incompatible DVR will result in problems such as B/W display, no video or the loss of PTZ control.

2.Camera Installation

Stage1:Before Mounting Outside

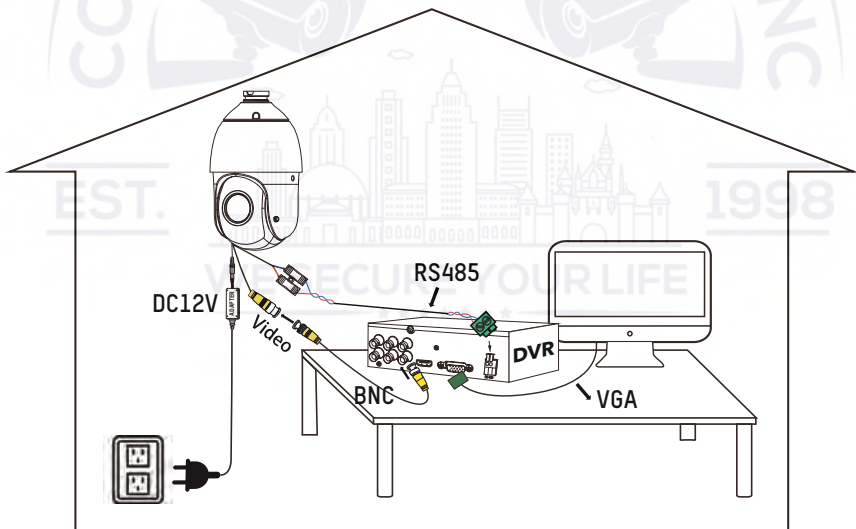

Use Default 12DVC Power Adapter! No Power Extension in Testing Phase!

Indoor Bench Test

When you first receive the PTZ camera, please make sure it works properly before mount the camera outside. Note PTZ dome cameras have higher power requirements than bullet cameras and corresponding IP cameras. Therefore, how the unit is powered can be critical to its functionality. Please make sure the unit itself is working, and try eliminating all cabling factors to set up the bench test.

How to Test Locally

In short, in a bench test, do NOT extend the power line. Please connect the camera with its default adapter.

Don't:

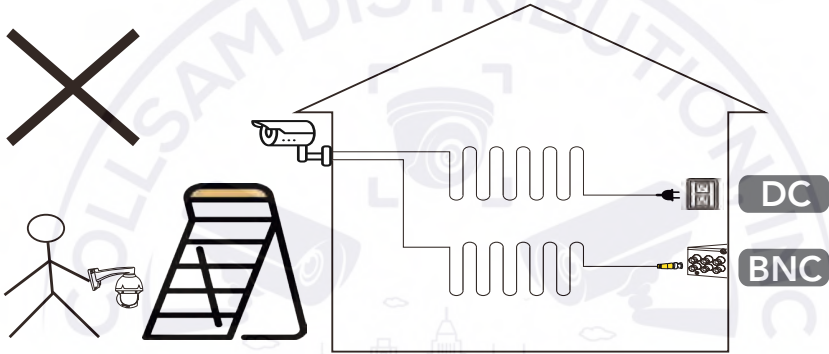

Do not directly apply the old wirings for bullet cameras on dome Cameras.

For example, if you have previously wired a fixed lens bullet camera and you remove the old camera and adopt old wires directly on Sunba PTZ dome camera, this is likely NOT working given two units have different power requirements.

Why Test Locally

The reason you should NOT extend the power cable during the bench test is because DC power drops along the cable. Underpower can cause problems such as 1) screen flickering, 2) unstable infrared (on/off automatically) and 3) camera spinning recklessly. A bench test helps you rule out all problems caused by power supply.

Stage2:Permanent Installation

With DVR

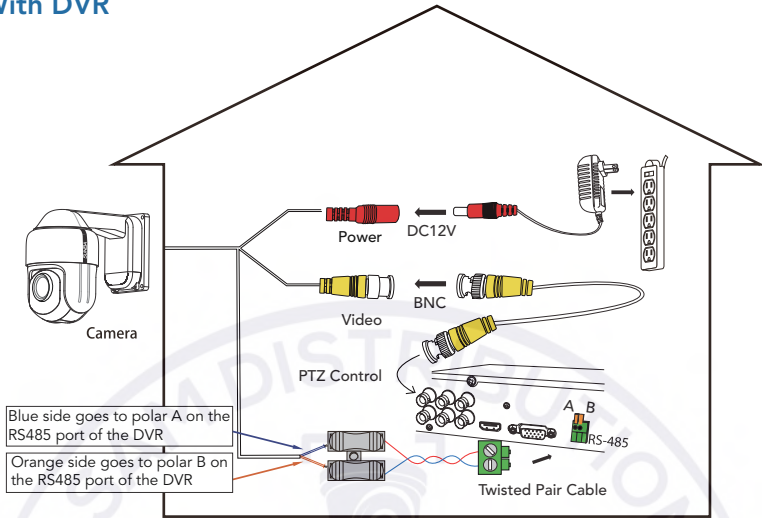

With CCTV Monitor and 3D Pan Tilt Zoom Joystick

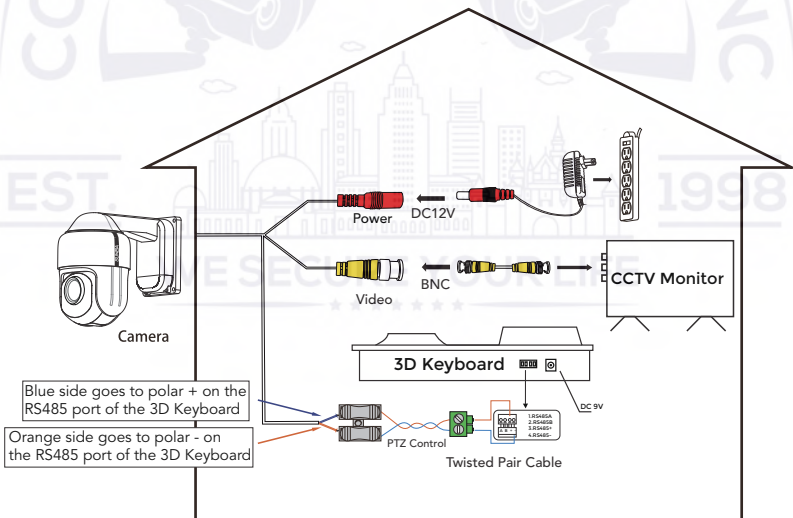

3. Mount Installation for 305-A4X

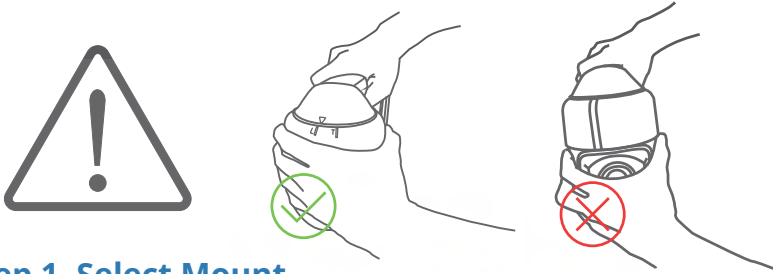

Step 1. Select Mount

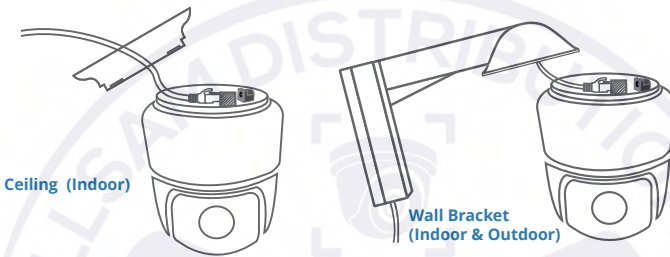

Step 2. Align ▽ with "L" next to Mark "L"



Step 3. Turn to Align ▽ with "T"

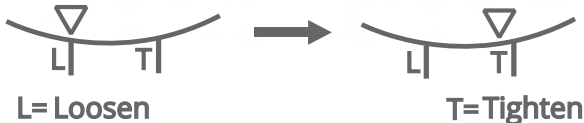

To tighten the mount, make sure the ▽ icon on the mount is aligned with the "L" mark on the camera top. Then gradually turn the mount counter-clockwisely so that ▽ is now aligned to "T".

4. Cable Extension Methods

1) AC cable: Make sure your AC power source is close enough to the camera. The easiest way is to get a premade AC extension cable (no distance limit). Power strip is an example.

2) DC cable: Make sure the wire is AWG18 or thicker (distance dependent). The thicker the cable, the smaller the electrical resistance and the longer it can run without voltage loss.

WARNING: Please strictly follow any applicable local security camera installation rules.

RS485 Cable

Please use any twisted pair from Ethernet cable (cat5/5e/6). Please ensure the direction of +/- or A/B are consistent on both DVR and camera's end. 3-in-1 cables are for bullet cameras and are not recommended as most of them are parallel instead of twisted.

DON'T

- 1) If it is an infrared camera, do not put a dome cover on the camera which will block and obscure the IR Led.
- 2) Use a cat5 as the extension for power adapter. Cat5 has strong electrical resistance (usually only AWG24) that can cause underpower.
- 3) Install the camera next to an electrical cable which will cause interference and degrade video quality.
- 4) Disassemble the camera without notifying Sunba support team. This may void the warranty.

5. Address Setting for PTZ



This chapter is NOT applicable if your device is AHD and you are using BNC coaxial connection for PTZ.

What is the PTZ address bit?

Address bit is the unique ID (virtual) for PTZ analog cameras so that the terminal controller (DVR/Joystick) can recognize each camera connected to it.

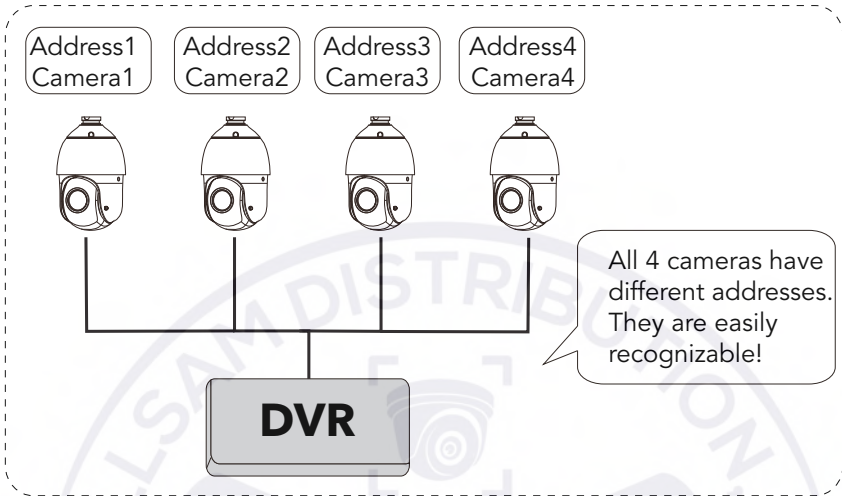

The default address of Sunba PTZ camera is 1. So if you buy 2 PTZ cameras without changing the address on the 2nd unit, then.....

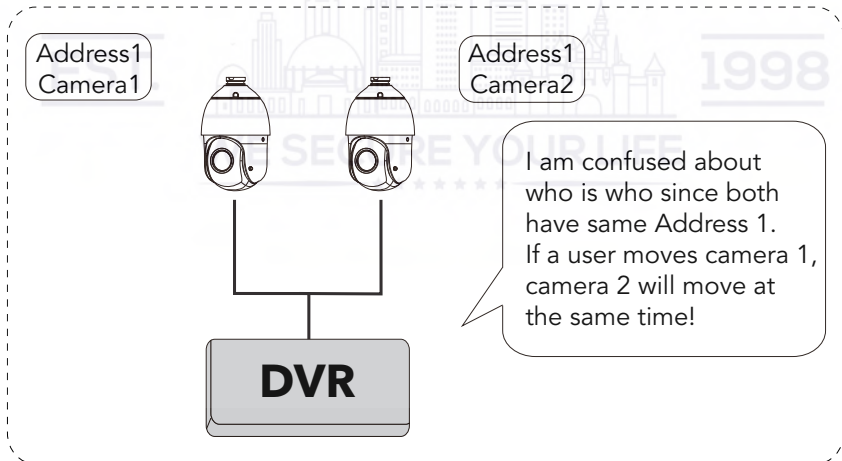

How to modify the PTZ address of the camera?

Please set the camera's address before using this dome. No same address (or ID) is allowed for more than one PTZ camera. By default, the address of PTZ camera is 1.

Step 1: Go to the **OSD Menu of the camera** by calling preset 95+CALL (refer to the manual of your DVR if you want to learn how to use/call preset). See **Chapter 5** for details of calling preset.

Step 2: The first item in the OSD menu is the address bit. Use the **left/right direction arrow** to modify the address. Use the **up and down direction arrow** to select item.



SOFT ADDR	1
PARK ACT	NONE
PARK TIMEV	15
FRAME SPEED	16
DWELL TIME	6
LED MODE	AUTO
LED ON	201
LED OFF	185
CAMERA	

Step 3: You **MUST** reboot the camera (cut and restore the power) before the soft address change takes effect.

Step 4: Don't forget to modify the correct address in the DVR's PTZ Control setup page correspondingly. The **PTZ Config** page can usually be found at "Main Menu" of the DVR.



WARNING: Failure to set the address bit here correspondingly will cause inability to PTZ.

Please change the address number that you just modified for the corresponding channel here.

	PTZ Device	RS485 Device
Channel	1	
Protocol	Pelco D	None
Address	1	1
Baud Rate	9600	9600
Data Bits	8	8
Stop Bits	1	1
Parity	None	None

Important:

If two cameras are both at the same address bit 1, you need to power one of the units off in order to modify the PTZ address bit of the other.

How to double check the current PTZ address of the camera?

Please **reboot** the device. After the self-diagnostic process of the camera. The camera will then display the current address information on the screen such as (ADDR = address):

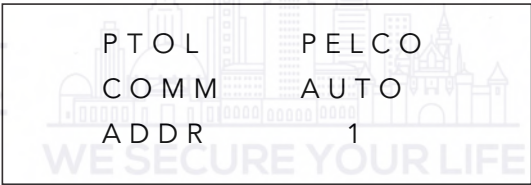

6. Preset and Patrol

PTZ Preset Position

Sunba dome cameras can set preset PTZ positions for which cameras can memorize and travel directly by calling the preset. Preset Positions are represented by numbers. You need to “add” a preset and then “call” it. You can always “delete” them later.

Special Presets

Special presets are preset numbers not associated with positions but to advanced commands that cameras can follow to modify/enable settings such as setting up special auto scan boundaries etc. You can call the preset directly (no need to "add" a special preset as they are pre-existed) according to The Full Preset List.

What does XX + CALL Mean? Example for 95+CALL below:

Every PTZ supported DVR has a built-in PTZ control panel on the screen. With Sunba's DVR, for example, enter 95 in the preset box on the control panel and hit "start" to call preset 95, which opens the OSD menu of the camera. The "start" button may have other names in different DVRs. Please refer to the manual of your DVR to learn the specific way of setting up/calling presets.

This is the preset control panel in Sunba's DVR:

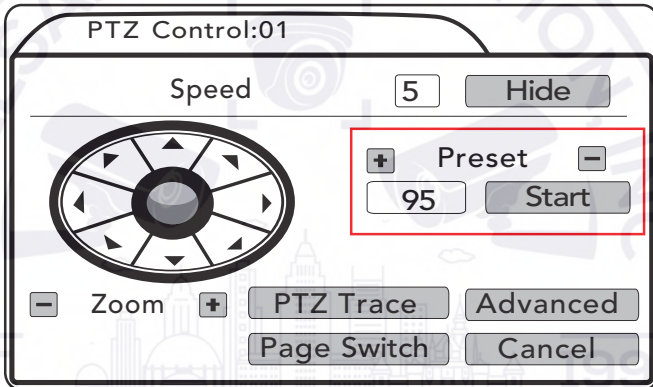

Patrol

The PTZ camera can travel from one preset to another by order. A patrol is also known as a **tour** or a **cruise**. The total presets included in a patrol can be up to 10. To activate a patrol, first you will need to save corresponding presets you want to tour across. For example, patrol over presets 1-10 can be activated by calling special preset 88 (see The Full Preset List).

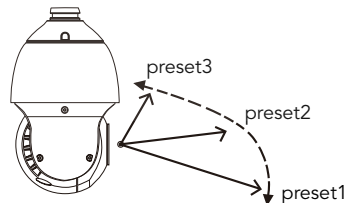
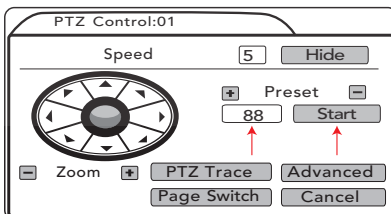

The Full Preset List

Special Preset	Function
0~50 Preset	Conventional Position Preset
XXX + Add Preset	Set preset XXX.
XXX + CALL	Call preset XXX.
95 + CALL	Open the On-Screen-Display menu of the camera
47 + SET	Set the left boundary of auto scan
48 + SET	Set the right boundary of auto scan
82 + CALL	Boundary auto scan (from 48 to 47 counter-clockwise)
83 + CALL	Clear all presets
88 + CALL	Patrol from 1 to 10 preset
89+ CALL	Patrol from 11 to 20 preset
90 + CALL	Patrol from 21 to 30 preset
91 + CALL	Patrol from 31 to 40 preset
92 + CALL	Reset to default
99 + CALL	360 degree scan
100 + CALL	IR on
101 + CALL	IR off
102 + CALL	IR auto
103 + CALL	IR all on
97+CALL + 116+CALL	Switch camera to AHD format (Need AHD-DVR Support)
97+CALL + 117+CALL	Switch camera to CVBS format
97+CALL + 118+CALL	Change camera signal to NTSC
97+CALL + 119+CALL	Change camera signal to PAL

Note:

If the camera is in a patrol or auto scan, it will stop immediately if it receives any further instructions from the user including pan, tilt, zoom etc. To ensure the camera resumes a patrol after that, please set up a Park Act following instruction from Chapter 6.

The preset list is up-to-date at the time of release. It may have slight change with the actual one you receive. If there is any question, feel free to contact Sunba.

7.Camera OSD Menu

Model: 305-A4X, 405-22X

When you open the OSD menu with preset 95+CALL, use the up and down keys to move the cursor, left key to go back to the previous menu, right key to select and confirm.

Preset 95 + call will appear the following menu:

MAIN MENU PAGE 1		MAIN MENU PAGE 2	
SOFT ADDR	1	RESET	
PARK ACT	NONE	EXIT	
PARK TIME	15		
FRAME SPEED	16		
DWELL TIME	6		
LED MODE	AUTO		
LED ON	201		
LED OFF	185		
CAMERA			

Description of each option from the menu:

1.SOFT ADDR

Set up the soft address of the camera (refer to Address Setting chapter for more details).

2.PARK ACT

This option is also called the watch function or the defend function of a PTZ camera. The dome will automatically execute a corresponding preset action after a settled idle time (15 seconds is default) if no additional commands were received from users. Control the up and down keys to select the option, and use the left and right direction arrow to select idle actions.

3.PARK TIME

The waiting time (or idle time) before the camera executes its PARK ACTION (see below). The default is 15 seconds.

4.FRAME SPEED

The rate the dome scans continuously between two preset points. Valid value 1~31. Please read the "The Full Preset List" to learn how to set left and right scan boundary.

5.LED MODE

A. AUTO MODE: Turn on and off IR LED automatically according to the value of photoresistor. If the value of the ambient environment (CURRENT LEVEL) is \geq the IR ON SENS, then the LED will be turned on automatically, vice versa. Larger CURRENT LEVEL is equivalent to darker environment.
B. MANUAL mode: Open and close the IR LED manually. This can be accomplished using The Special Presets (see the preset list above).

6. IR ON SENS

The value of photoresistor to turn on the IR LED, default is 210.

7. IR OFF SENS

The value of photoresistor to turn off the IR LED, default is 185. The difference between the LED ON and LED OFF values must be at least 30 to avoid problems of IR LED blinking. Only half side of IR will be on for nearview, please zoom in to enable the further view and the other side of the IR. PRESET 130+CALL to manually turn on both sides together.

Note: Two values of IR ON and OFF need to keep 30 of the gap to avoid the problem of IR LED blinking repeatedly.

8. CAMERA

This menu is for engineer's development purpose and is not open to end-users.

9. RESET

Restore the camera to default.

8.Troubleshooting

Built-in Self Test

When powered up, the speed dome will automatically begin a self -diagnostic process during which the camera will pan horizontally and vertically to make sure PTZ, lens and other parts of the camera are functional. Please contact our technical staff if a self-test does not happen on your unit. Please refrain from disassembling the unit before contacting us.

Symptom	Reason & Solution
PTZ not working properly	<ol style="list-style-type: none"> 1.Bad RS485 cable: try another twister pair or change to another Ethernet cable or try tightening the connector; 2.RS485 in wrong polarity: switching the order of the pair to ensure it matches the +/- of the RS485 ports; 3.Loosen belt during transportation: tighten the tilt and pan belt (ask Sunba for instruction); 4.Make sure the RS485 connector is functional; 5.See the "Address Setting" Chapter to ensure the camera has correct corresponding address set in Main Menu->PTZ Config of the DVR. Check ptz.sunba.net for more details.
B/W display	The signal of camera and DVR are not consistent (both needs to be PAL or NTSC); this may happen after a reset.
Red lights on but no power	Defective power adapter; test with another adapter to confirm and ask Sunba to send a replacement adapter.
Video disconnection	<ol style="list-style-type: none"> 1. Bad BNC cable: replace to a new BNC cable or try to tighten the connection 2. Underpower
Camera powers off automatically	<ol style="list-style-type: none"> 1. Underpower 2. Adapter defects; test with another adapter to confirm and ask Sunba to send a replacement adapter
Flashing/flickering screen	Underpower
Camera reboots at night	Underpower
Camera spinning automatically	Underpower

9. Warranty Claim Step

Contact Sunba support team with the following information. This is not necessary if you want to send the camera to Sunba repairing center as our technician will fully check the camera. It is necessary, however, if you are requesting parts from Sunba for replacement.

Name		
Order Number	Condition	
Camera Features	Yes <input type="checkbox"/>	No <input type="checkbox"/>
Pan working?	Yes <input type="checkbox"/>	No <input type="checkbox"/>
Tilt working?	Yes <input type="checkbox"/>	No <input type="checkbox"/>
Zoom working?	Yes <input type="checkbox"/>	No <input type="checkbox"/>
Power up Self-test working?	Yes <input type="checkbox"/>	No <input type="checkbox"/>
Checked RS485?	Yes <input type="checkbox"/>	No <input type="checkbox"/>
Checked BNC?	Yes <input type="checkbox"/>	No <input type="checkbox"/>
Describe how you powered the camera, including the length of extension cable or anything relevant.		
Describe the problem you have, or parts you want to obtain for self-installation.		

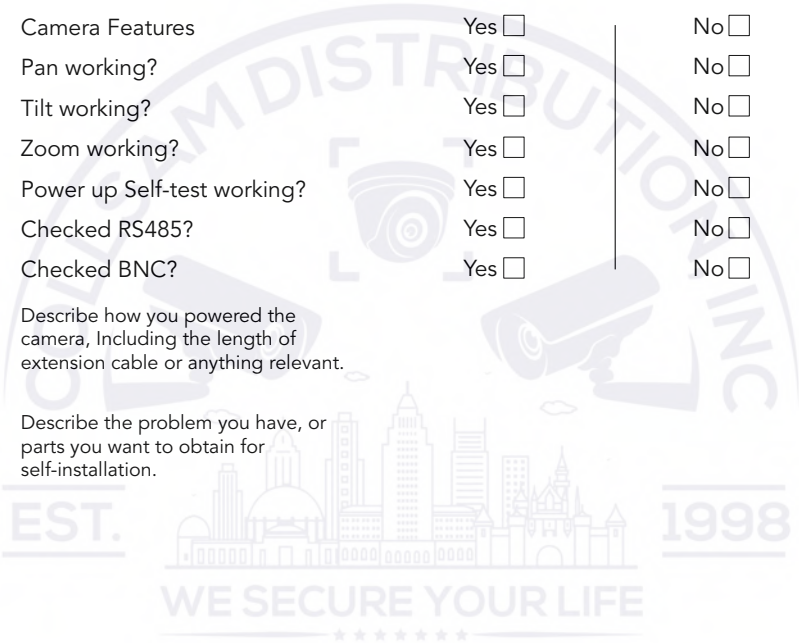

Warranty Statement

1.This product comes with a 2-year limited US warranty covering parts only (1-Yr in other regions). You must pay the labor fee for repair inside the warehouse. However, any parts replacements are always covered and we will be sending you videos & instructions on how to fix the unit. Please contact us first within the warranty period to make sure the condition of warranty is met.

2.Our warranty does not extend to any products that are physically damaged or are not under normal operating conditions as a result of misuse or improper installation on the user's end.

Sunba's Return Policy

**Return Window

Please return your product within 30 days of your receipt. That's the official deadline the return request must be received. Exception applies for items in resellable conditions.

**RMA

We will provide a Returned Merchandise Authorization (RMA) Number for each item that satisfies the return request. Please put your RMA sheet inside the box for reference to expedite the refund process. All products must be returned within 14 days from the RMA issuing date.

**Complete Package Rule

Please return the product with its original packaging, including manuals, brackets and toolkit that come with the unit for a full refund. According to Amazon's restocking fee policy, returns with incomplete/materially different package may enable sellers to charge a restocking fee up to 15% subject to the completeness of the package. Therefore, please make sure you keep the package in good condition in the period of valid return window to avoid any additional charge.

**Refund

If you didn't receive an automatic refund within 10 days of the receipt of your return, it is either the RMA was not attached to the package or the RMA was lost by the warehouse. In this case, please kindly provide us with your tracking number so that we can match the return package and the refund will be manually processed within 24 hours. Please watch your email notifications.

For any questions, don't hesitate to reach support@sunba.net SUNBA® Technology

