

# DH-PFA107

## Adapter Plate of PT Network Camera



### Features

- Compatible cameras Mini PTZ Network Cameras
  - 1A203TNI
  - 12203TNI
- Made of Aluminum Structure
- Load bearing capacity of 4.4 lb (2 kg)
- High-efficiency motion control
- Improved surveillance accuracy
- Security and surveillance Industrial and Commercial
- Durable
- Cost-effective
- Easy to install

### Technical Specifications

<b>Model</b>	<b>DH-PFA107</b>
<b>General</b>	
Material	Aluminum
Dimension (DIA x H)	Φ134.1mmx83.5mm (Φ5.28"x3.29")
Weight	0.29kg(0.64lb)
Load Bearing	1kg(2.2lb)
Color	White
Operating Temperature	-40°C ~60°C(-40°F ~140°F)
Humidity	<90% RH
Applicable Model	DH-PFB305W, DH-PFB220C

**Dimensions (mm/inch)**

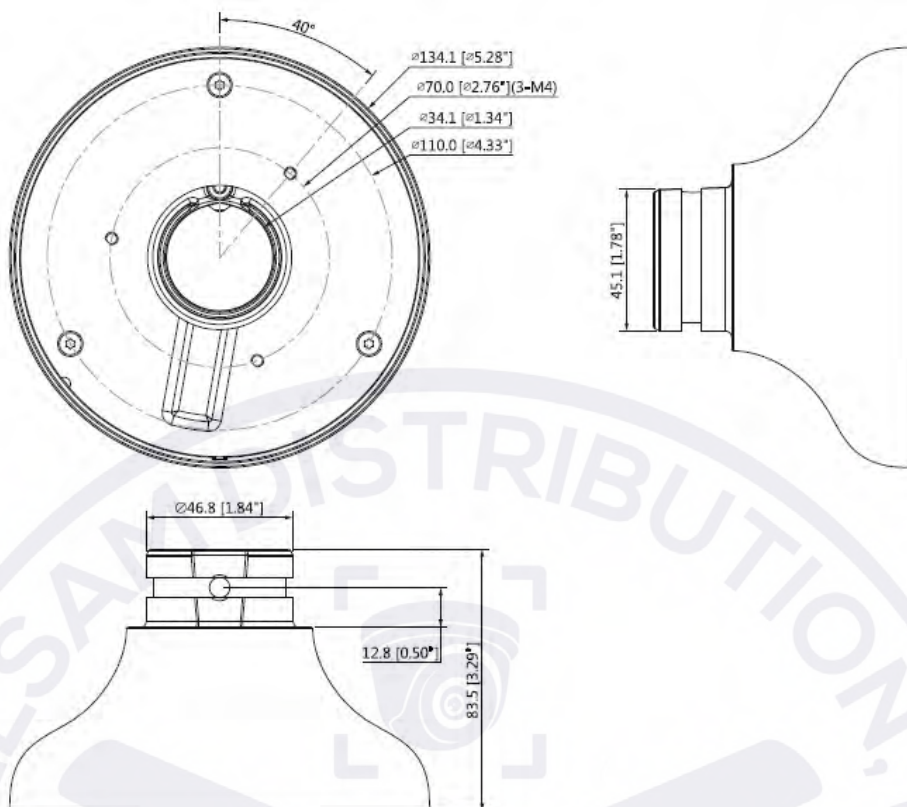

**Application**

Wall Mount	Ceiling Mount
PFB305W+PFA107	PFB220C+PFA107
