

Mount Adapter

for DH-IPC-PDBW5831N-B360-E4 Multi-sensor Dome Camera



- Made of Aluminum
- Compatible with DH-IPC-PDBW5831N-B360-E4 Multi-sensor Dome Camera
- Easy to Install
- Durable and Stable Support
- Low-profile Design

Technical Specifications

Material	Aluminum
Color	White
Dimensions (W x H)	ø140.0 mm x 39.50 mm (ø5.51 in. x 1.56 in.)
Load Bearing Capacity	3.0 kg (6.61 lb)
Weight	0.23 kg (0.51 lb)
Operating Temperature	-40 °C to 60 °C (-40 °F to 140 °F)
Humidity	< 90% RH
Compatibility	DH-IPC-PDBW5831N-B360-E4 Multi-sensor Dome Camera

Dimensions (mm/in.)

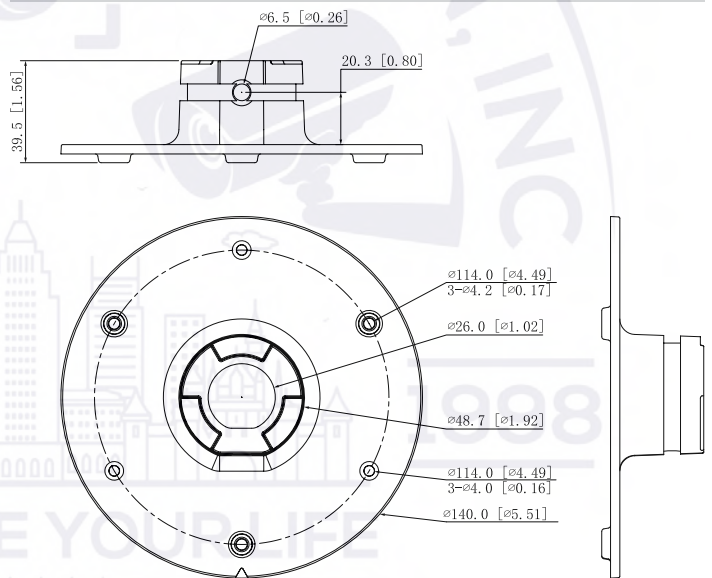

Ordering Information

Type	Part Number	Description
Mount Adapter	DH-PFA108	Multi-sensor Dome Camera Mount Adapter
Package Contents	3 x M4 x 10 Screws	
	1 x S5.0 Hex Wrench	