



Installation & Operation Manual

V2100D-ICD In-Ceiling Mounting Kits

Vicon Industries Inc. does not warrant that the functions contained in this equipment will meet your requirements or that the operation will be entirely error free or perform precisely as described in the documentation. This system has not been designed to be used in life-critical situations and must not be used for this purpose.

Document Number: 8009-8318-98-00 Product specifications subject to change without notice. Issued: 8/21 Copyright © 2021 Vicon Industries Inc. All rights reserved.

Vicon Industries Inc.
Tel: 631-952-2288 Fax: 631-951-2288
Toll Free: 800-645-9116
24-Hour Technical Support: 800-34-VICON
(800-348-4266) UK: 44/(0) 1489-566300
www.vicon-security.com

Introduction

The information in this manual covers the installation, operation, and maintenance of the V2100D-ICD In-Ceiling Mounting Kits for the V2100D Series of Dome Cameras. These units should only be installed by a qualified technician using approved materials and wiring practices in accordance with the national Electric Code ANSI/NFPA 70, state, and local codes. Read these instructions through completely before attempting installation.

The V2100D-ICD is designed to allow the V2100D camera to be mounted into a dropped ceiling. These mounting kits provide a sturdy support when an in-ceiling installation is required. Refer to Table 1.

**Table 1
Product Description**

Model Number	Description
V2100D-ICD	In-ceiling mounting kit for drop ceilings; includes mounting rails (packaged separately) and all necessary hardware

Installation

The V2100D-ICD In-Ceiling Mounting Kits include all the components necessary to complete the installation, including appropriate hardware.

Table 2: Mounting Kit Components

V2100D-ICD		
Paper template	1	Used to mark exact hole to cut for dome installation
Mounting rails and mounting bracket assembly	1	Secures camera dome assembly to the drop ceiling supports
Interface frame assembly	1	Adapts camera dome for in-ceiling installation
Dome dress plate	1	Masks the tile cut hole at final installation; attached to interface frame assembly for shipping purposes
8-32x2 flat head mounting screws	4	Secures interface frame assembly to the in-ceiling mounting bracket
6-32x5/8 pan head screws with lock and flat washers	4 sets	Secures camera base to interface plate; extra set of hardware is provided
6-32x3/8 flat head dome dress plate screws	4	Secures the dome dress plate to interface frame assembly

The ceiling material must provide suitable strength to support the weight of the V2100D camera and interface frame assembly (2.4 lb, 1.1 kg). Be sure the area around the selected location is clear of obstacles (such as steel beams, headers, pipes, electrical wiring, etc.) that would interfere with mounting. Video and power cables must be routed to the location. Before beginning installation, refer to the Quick Guide for the V2100D Mini Dome Camera, XX318-20, for complete instructions.

Using the Template

A paper template is provided to assist in marking an accurate hole size in a hard ceiling or a ceiling tile for in-ceiling installations (note there are separate templates for the hard ceiling or drop ceiling kit). Refer to Figures 1 and 7 and use as follows:

Installing the V2100D-ICD

1. Remove the camera frame assembly from the shipping container and detach the dome dress plate, as shown in Figure 2.
Note that the in-ceiling mounting bracket is not included in the V2100D-ICD kit.
2. If not already done, cut a hole in the ceiling tile using the paper template provided. Refer to Using the Template section but use the template for the V2100D-ICD shown in Figure 7 below. Place the template at the center of the required location, mark the outer profile and cut the hole in the tile.

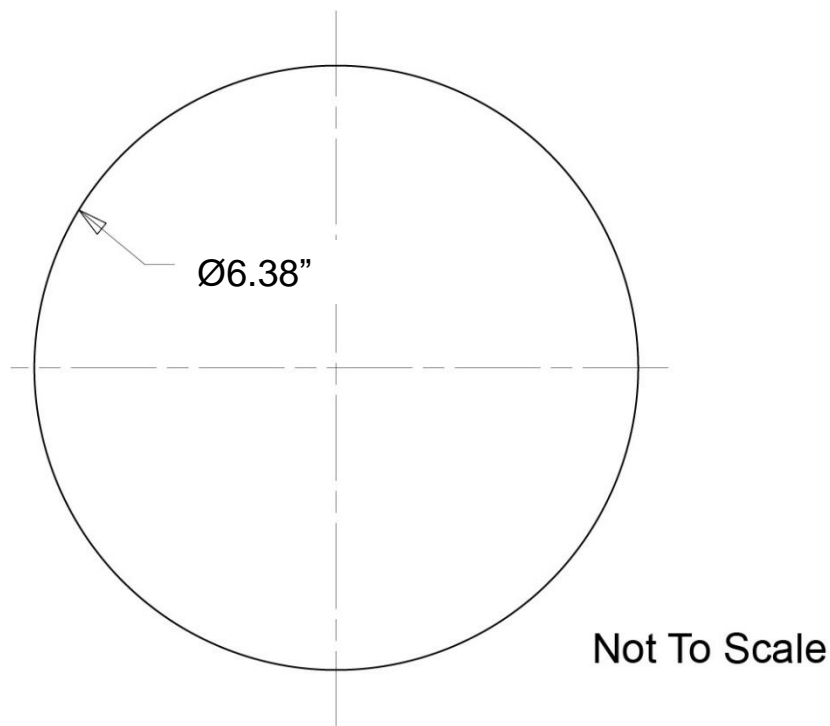

Figure 7
V2100D-ICD Template

3. Remove adjacent tiles to access the clips to attach the mounting bracket assembly.
4. The mounting bracket assembly, rail kits and accessories are shipped in three separate packages.
5. Insert one rail through the slot in the bracket; the rail can only go through one way. Insert another rail on the same side from the opposite direction so that there is a clip on both ends. Repeat this procedure on the other side of the bracket. Tighten screws as needed to secure the rails.
6. Working from the adjacent tile area, position this rail/bracket assembly squarely over the hole and fasten the caddy rail clips to the existing frame. Refer to Figure 8.
7. Tighten the horizontal adjustment screws to secure the position.
8. Secure the interface frame assembly to the caddy rail mounting plate using the four (4) 8-32x2 flat head screws provided. Align the four (4) countersunk holes in the interface frame assembly to the

four (4) holes in the caddy rail mounting plate. Tighten each screw a little at a time until snug. Do NOT OVERTIGHTEN screws. Refer to Figure 8.

9. Prior to attaching the V2100D camera to the interface frame assembly, extend the I/O cabling with I/O connectors through the ceiling hole. Refer to the V2100D Quick Guide for the cable connections.
10. Remove the V2100D trim ring assembly from the camera base and, with the base relatively close to the opening, install the I/O cable according to the instructions in the V2100D Quick Guide. Mount the camera base to the interface frame assembly using the no. 6 hardware provided; the hardware is magnetic and using a magnetic tip screwdriver will aid in the installation. Refer to V2100D Quick Guide for details on camera setup.
11. After setting up the camera, reattach the camera lower dome assembly to the camera base. Then attach the dome dress plate to the interface frame assembly using Figure 6 as a guide.

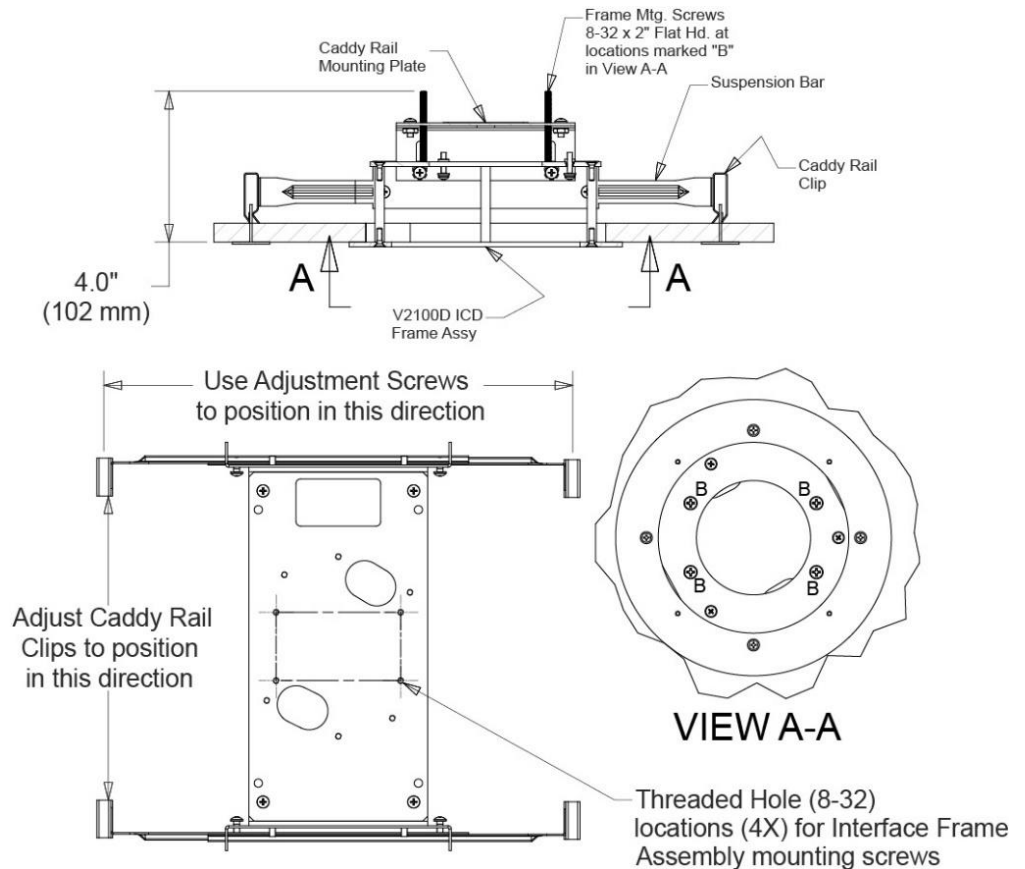

Figure 8
V2100D-ICD Installation

Vicon Standard Equipment Warranty

Vicon Industries Inc. (the "Company") warrants your equipment to be free from defects in material and workmanship under Normal Use from the date of original retail purchase for a period of three years, with the following exceptions:

1. Access Control System Components: Two year from date of original retail purchase. Some credentials have a lifetime warranty; refer to VAX warranty document for details.
2. Thermal Body Temperature Camera and Biometric Thermal Kiosk: Two years from date of original retail purchase.
3. Thermal Sensor VTR-3XXX/VTR-6XXX: One year from date of original retail purchase.
4. For PTZ cameras, "Normal Use" excludes prolonged use of lens and pan-and-tilt motors, gear heads, and gears due to continuous use of "autopan" or "tour" modes of operation. Such continuous operation is outside the scope of this warranty.
5. Any product sold as "special" or not listed in Vicon's commercial price list: One year from date of original retail purchase.

NOTE:

- If the product is to be used outdoors or in dusty, humid, or other hostile environments, it must be suitably protected.
- Camera products must be protected, whether in use or not, from exposure to direct sunlight or halogen light as the light may damage the camera image sensor. This applies to both indoor and outdoor use of the cameras.
- Failure to comply with any of the aforementioned requirements will invalidate this Limited Hardware Warranty.

Date of retail purchase is the date original end-user takes possession of the equipment, or, at the sole discretion of the Company, the date the equipment first becomes operational by the original end-user.

The sole remedy under this Warranty is that defective equipment be repaired or (at the Company's option) replaced, at Company repair centers, provided the equipment has been authorized for return by the Company, and the return shipment is prepaid in accordance with policy. Repaired or replacement hardware will be warranted for the remainder of the original Warranty Period or ninety (90) days, whichever is longer. When a product or part is exchanged the replacement hardware becomes the property of the original purchaser and all hardware or part thereof that is replaced shall become the property of Vicon.

The warranty does not apply (a) to faulty and improper installation, maintenance, service, repair and/or alteration in any way that is not contemplated in the documentation for the product or carried out with Vicon consent in writing, operation adjustments covered in the operating manual for the product or normal maintenance, (b) to cosmetic damages, (c) if the product is modified or tampered with, (d) if the product is damaged by acts of God, misuse, abuse, negligence, accident, normal wear and tear and deterioration, improper environmental conditions (including, but not limited to, electrical surges, water damage, chemical exposure, an/or heat/cold exposure) or lack of responsible care, (e) if the product has had the model or serial number altered, defaced or removed, (f) to consumables (such as storage media or batteries) (g) to products that have been purchased "as is" and Vicon the seller or the liquidator expressly disclaim their warranty obligation pertaining to the product, (h) to any non-Vicon hardware product or any software (irrespective of packaged or sold with Vicon hardware product) and Vicon products purchased from an unauthorized distributor/reseller, (i) to damage that occurs in shipment or (j) to damages by any other causes not related to defective design, workmanship and/or materials.

The warranty for the products shall run from Vicon to End User customers only (including product purchased through authorized partners and resellers). Vicon is not obligated under any circumstances to honor warranties on product(s) purchases from internet auction sites including eBay, uBid or from any other unauthorized resellers. Except as explicitly provided herein, Vicon disclaims all other warranties, including the implied warranties of fitness for a particular purpose and merchantability.

Software supplied either separately or in hardware is furnished on an "As Is" basis. Vicon does not warrant that such software shall be error (bug) free. Software support via telephone, if provided at no cost, may be discontinued at any time without notice at Vicon's sole discretion. Vicon reserves the right to make changes to its software in any of its products at any time and without notice.

The Warranty and remedies provided above are exclusive and in lieu of all other express or implied warranties including, but not limited to, the implied warranties of merchantability or fitness for a particular purpose. Certain jurisdictions do not allow the exclusion of implied warranties. If laws under such jurisdictions apply, then all express and implied warranties are limited to the warranty period identified above. Unless provided herein, any statements or representations made by any other person or firm are void. Except as provided in this written warranty and to the extent permitted by law, neither Vicon nor any affiliated shall be liable for any loss, (including loss of data and information), inconvenience, or damage, including, but not limited to, direct, special, incidental or consequential damages, resulting from the use or inability to use the Vicon product, whether resulting from breach of warranty or any other legal theory. Notwithstanding the foregoing, Vicon total liability for all claims under this warranty shall not exceed the price paid for the product. These limitations on potential liabilities have been an essential condition in setting the product.

No one is authorized to assume any liability on behalf of the Company, or impose any obligations on it in connection with the sale of any Goods, other than that which is specified above. In no event will the Company be liable for indirect,

special, incidental, consequential, or other damages, whether arising from interrupted equipment operation, loss of data, replacement of equipment or software, costs or repairs undertaken by the Purchaser, or other causes.

This warranty applies to all sales made by the Company or its dealers and shall be governed by the laws of New York State without regard to its conflict of laws principles. This Warranty shall be enforceable against the Company only in the courts located in the State of New York.

The form of this Warranty is effective May 1, 2021.

THE TERMS OF THIS WARRANTY APPLY ONLY TO SALES MADE WHILE THIS WARRANTY IS IN EFFECT. THIS WARRANTY SHALL BE OF NO EFFECT IF AT THE TIME OF SALE A DIFFERENT WARRANTY IS POSTED ON THE COMPANY'S WEBSITE, WWW.VICON-SECURITY.COM. IN THAT EVENT, THE TERMS OF THE POSTED WARRANTY SHALL APPLY EXCLUSIVELY.



VICON INDUSTRIES INC.

For office locations, visit the website: vicon-security.com