

Junction Box

- Aluminum Construction
- Durable Aluminum Construction
- Weatherproof Finish
- 7.0 kg (15.43 lb) Load Bearing Capacity
- Compatible with Dahua Multi-Sensor Panoramic Bullet Cameras
- The Dahua DH-PFA120-SG Junction Box from Dahua Technology is an aluminum junction box with a silver or gray finish.
- It is suitable for camera mounting with operating temperatures from -40 °F (-40 °C) to 140 °F (60 °C)
- Relative humidity less than 90%.



Technical Specifications

| | |
|------------------------|---|
| Material | Aluminum |
| Dimensions (W x H x D) | 115.0 mm x 160.0 x 38.80 mm (4.53 in. x 6.30 x 1.53 in.) |
| Pipe Thread | M20 (G1/2 in.) |
| Weight | 0.53 kg (1.17 lb) |
| Load Bearing Capacity | 7.0 kg (15.43 lb) |
| Color | Silver-gray |
| Operating Temperature | -40 °C to 60 °C (-40 °F to 140 °F) |
| Humidity | < 90% RH |
| Compatibility | DH-IPC-PFW8840N-A180 |

Dimensions (mm)

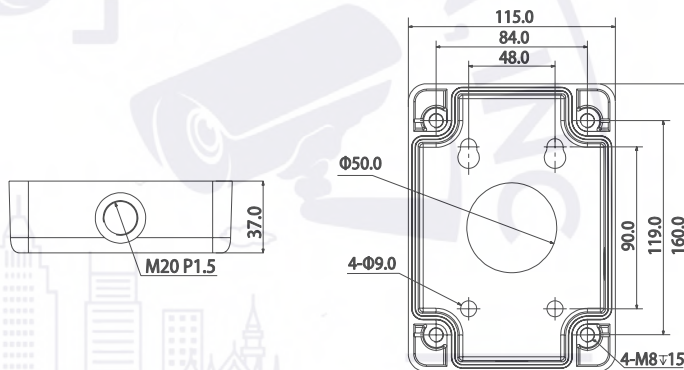

Ordering Information

| Type | Part Number | Description |
|--------------|--------------|---------------------------|
| Junction Box | DH-PFA120-SG | Junction Box, silver-gray |

Camera Compatibility

- IPC-PFW83242-A180-S2
- IPC-PFW81642-A180
- IPC-PFW8840-A180
- IPC-PFW83242-A180