

NETWORK I/O BOX

User Manual

SPM-4210



EST.



WE SECURE YOUR LIFE



1998

COLLSAM SECURITY

Network I/O Box User Manual

Copyright

©2020 Hanuwa Vision Co., Ltd. All rights reserved.

Trademark

Each of trademarks herein is registered. The name of this product and other trademarks mentioned in this manual are the registered trademark of their respective company.

Restriction

Copyright of this document is reserved. Under no circumstances, this document shall be reproduced, distributed or changed, partially or wholly, without formal authorization.

Disclaimer

Hanuwa Vision makes the best to verify the integrity and correctness of the contents in this document, but no formal guarantee shall be provided. Use of this document and the subsequent results shall be entirely on the user's own responsibility. Hanuwa Vision reserves the right to change the contents of this document without prior notice.

※ Design and specifications are subject to change without prior notice.

※ The initial administrator ID is "admin" and the password should be set when logging in for the first time.

Please change your password every three months to safely protect personal information and to prevent the damage of the information theft.

Please, take note that it's a user's responsibility for the security and any other problems caused by mismanaging a password.

EST.

1998

WE SECURE YOUR LIFE

IMPORTANT SAFETY INSTRUCTIONS

1. Read these instructions.
2. Keep these instructions.
3. Heed all warnings.
4. Follow all instructions.
5. Do not use this apparatus near water.
6. Clean the contaminated area on the product surface with a soft, dry cloth or a damp cloth. (Do not use a detergent or cosmetic products that contain alcohol, solvents or surfactants or oil constituents as they may deform or cause damage to the product.)
7. Do not block any ventilation openings. Install in accordance with the manufacturer's instructions.
8. Do not install near any heat sources such as radiators, heat registers, stoves, or other apparatus (including amplifiers) that produce heat.
9. Do not defeat the safety purpose of the polarized or grounding-type plug. A polarized plug has two blades with one wider than the other. A grounding type plug has two blades and a third grounding prong. The wide blade or the third prong are provided for your safety. If the provided plug does not fit into your outlet, consult an electrician for replacement of the obsolete outlet.
10. Protect the power cord from being walked on or pinched particularly at plugs, convenience receptacles, and the point where they exit from the apparatus.
11. Only use attachments/ accessories specified by the manufacturer.
12. Use only with the cart, stand, tripod, bracket, or table specified by the manufacturer, or sold with the apparatus. When a cart is used, use caution when moving the cart/ apparatus combination to avoid injury from tip-over.
13. Unplug this apparatus during lighting storms or when unused for long periods of time.
14. Refer all servicing to qualified service personnel. Servicing is required when the apparatus has been damaged in any way, such as power-supply cord or plug is damaged, liquid has been spilled or objects have fallen into the apparatus, the apparatus has been exposed to rain or moisture, does not operate normally, or has been dropped.
15. This product is intended to be supplied by a Listed Power Supply Unit marked "Class 2" or "LPS" and rated from PoE(48 Vdc), 0.1A.
16. This product is intended to be supplied by isolation power.
17. If you use excessive force when installing the product, the product may be damaged and malfunction. If you forcibly install the product using non-compliant tools, the product may be damaged.
18. Do not install the product in a place where chemical substances or oil mist exists or may be generated. As edible oils such as soybean oil may damage or warp the product, do not install the product in the kitchen or near the kitchen table. This may cause damage to the product.
19. When installing the product, be careful not to allow the surface of the product to be stained with chemical substance. Some chemical solvents such as cleaner or adhesives may cause serious damage to the product's surface.
20. If you install/disassemble the product in a manner that has not been recommended, the production functions/ performance may not be guaranteed. Install the product by referring to "Installation & connection" in the user manual.
21. Installing or using the product in water can cause serious damage to the product.



WARNING

TO REDUCE THE RISK OF FIRE OR ELECTRIC SHOCK, DO NOT EXPOSE THIS PRODUCT TO RAIN OR MOISTURE. DO NOT INSERT ANY METALLIC OBJECT THROUGH THE VENTILATION GRILLS OR OTHER OPENINGS ON THE EQUIPMENT.

Apparatus shall not be exposed to dripping or splashing and that no objects filled with liquids, such as vases, shall be placed on the apparatus.

To prevent injury, this apparatus must be securely attached to the Wall/ceiling in accordance with the installation instructions.

CAUTION

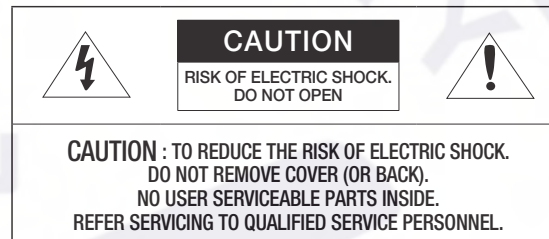

EXPLANATION OF GRAPHICAL SYMBOLS



The lightning flash with arrowhead symbol, within an equilateral triangle, is intended to alert the user to the presence of "dangerous voltage" within the product's enclosure that may be of sufficient magnitude to constitute a risk of electric shock to persons.



The exclamation point within an equilateral triangle is intended to alert the user to the presence of important operating and maintenance (servicing) instructions in the literature accompanying the product.

Class I construction

An apparatus with CLASS I construction shall be connected to a MAINS socket outlet with a protective earthing connection.

Battery

Batteries (battery pack or batteries installed) shall not be exposed to excessive heat such as sunshine, fire or the like.

The battery cannot be replaced.

Disconnection Device

Disconnect the main plug from the apparatus, if it's defected. And please call a repair man in your location.

When used outside of the U.S., it may be used HAR code with fittings of an approved agency is employed.

CAUTION

RISK OF EXPLOSION IF BATTERY IS REPLACED BY AN INCORRECT TYPE.
DISPOSE OF USED BATTERIES ACCORDING TO THE INSTRUCTIONS.

ATTENTION

IL Y A RISQUE D'EXPLOSION SI LA BATTERIE EST REMPLACÉE PAR UNE BATTERIE DE TYPE INCORRECT.

METTRE AU REBUT LES BATTERIES USAGÉES CONFORMÉMENT AUX INSTRUCTIONS.

These servicing instructions are for use by qualified service personnel only.

To reduce the risk of electric shock do not perform any servicing other than that contained in the operating instructions unless you are qualified to do so.

The ITE is to be connected only to PoE networks without routing to the outside plant.

The wired LAN hub providing power over the Ethernet (PoE) in accordance with IEEE 802.3af shall be a UL Listed device with the output evaluated as a Limited Power Source as defined in UL60950-1 or PS2 as defined in UL62368-1.

Unit is intended for installation in a Network Environment 0 as defined in IEC TR 62102. As such, associated Ethernet wiring shall be limited to inside the building.

Please read the following recommended safety precautions carefully.

- Do not place this apparatus on an uneven surface.
- Do not install on a surface where it is exposed to direct sunlight, near heating equipment or heavy cold area.
- Do not place this apparatus near conductive material.
- Do not attempt to service this apparatus yourself.
- Do not place a glass of water on the product.
- Do not install near any magnetic sources.
- Do not block any ventilation openings.
- Do not place heavy items on the product.
- Please wear protective gloves when installing/removing the product. The high temperature of the product surface may cause a burn.

User's Manual is a guidance book for how to use the products.

The meaning of the symbols are shown below.

- Reference : In case of providing information for helping of product's usages
- Notice : If there's any possibility to occur any damages for the goods and human caused by not following the instruction

※ Please read this manual for the safety before using of goods and keep it in the safe place.

We do not guarantee the quality of third-party products (e.g. lenses, accessories) that you separately purchase.

EST.

1998

OVERVIEW 3
3 Important Safety Instructions
6 Recommended PC Specifications
6 What's Included
7 At a Glance

INSTALLATION & CONNECTION 8
8 Connecting with other Device

NETWORK CONNECTION AND SETUP 11
11 Connecting the product Directly to Local Area Networking
11 Using Device Manager
11 Automatically searching product
11 Configuring IP address
12 Manually registering product
13 Automatically configuring IP
13 Port Range Forward (Port Mapping) Setup
13 Connecting to the product from a Shared Local PC

WEB VIEWER 14
14 Connecting to the product
14 Password setting
14 Login
14 Setting up product
14 Connecting camera with product

APPENDIX 15
15 Troubleshooting

EST.

1998

WE SECURE YOUR LIFE

RECOMMENDED PC SPECIFICATIONS

- CPU : Intel(R) Core(TM) i7 3.4 GHz or higher
- RAM : 8G or higher
- Recommended browser: Chrome
- Supported browsers: Chrome, Safari, Firefox, MS Edge(chromium based)
- Supported OS : Windows, Mac, Linux, Android, iOS, Chrome
- Verification environment
 - Windows 10: Google Chrome version 80 or later, Firefox version 72 or later, MS Edge version 83 or later
 - Mac 10.13/14: Safari version 11.0.1 or later

WHAT'S INCLUDED

Please check if your product and accessories are all included in the product package.
(As for each sales country, accessories are not the same.)

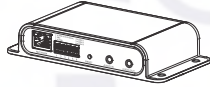
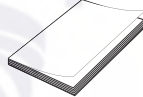
Appearance	Item Name	Quantity	Description
	Network I/O Box	1	External connection device for camera's alarm and audio I/O
	Quick Guide (Optional)	1	

Rear Side

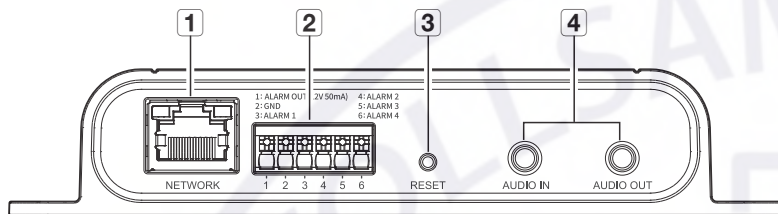

Item	Description	
1 Network port	This port connects power and network via PoE injector.	
2 Alarm I/O Port	ALARM OUT (12V, 50mA)	A port that connects to a sensor or warning light that is 12V/50mA or below.
	GND	Used for earth-grounding.
	ALARM1~4	A port that connects an alarm input sensor, external day/night sensor, or alarm output device.
3 Reset Button	<p>The button restores all product settings to the factory default. Press and hold for about 5 seconds to reboot the system.</p> <p>! If you reset the product, the network settings will be adjusted so that DHCP can be enabled. If there is no DHCP server in the network, you must run the Device Manager program to change the basic network settings such as IP address, Subnet mask, Gateway, etc., before you can connect to the network.</p>	
4 Audio cable port	AUDIO OUT	Used to connect to speakers.
	AUDIO IN	Used to connect to a microphone.



WE SECURE YOUR LIFE

CONNECTING WITH OTHER DEVICE

Powering and networking

Connect the PoE device of the camera-connected network to the network port of the product.

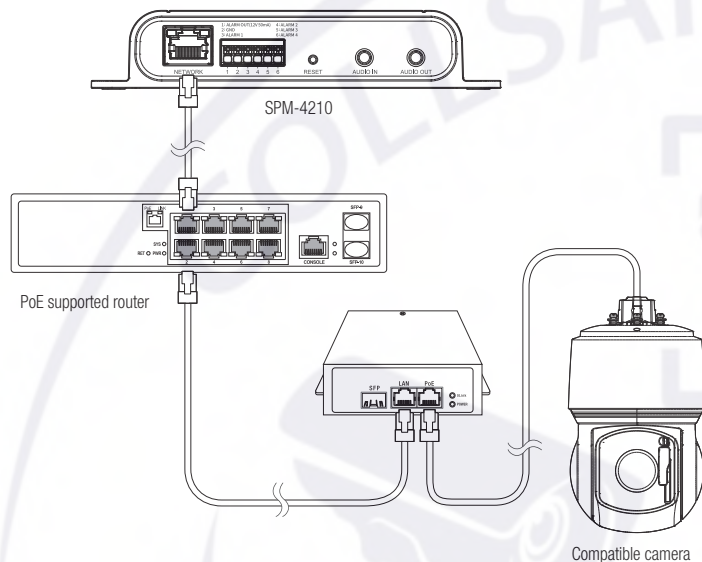

- ! ■ Connect and use a PoE enabled router.
- Use a PoE device that complies with the IEEE 802.3af standard.
- If you connect using an PoE enabled router, you don't need a separate power supply cable to power it on.
- It is recommended to connect the product and camera to the same router in order to prevent communication latency.
- Connect only one camera per network I/O box. The product may malfunction if more than one camera is connected.
- Download the DataSheet from the website of Harwha Vision (<https://www.harwhavision.com>) to see the list of models compatible with this product.

Network Cable Specification

Item	Contents	Remark
Connector	RJ45 (10/100BASE-T)	
Ethernet	10/100BASE-T	
Cable	Category 5e	
Max Distance	100 m	DC Resistance ≤ 0.125 Ω/m
PoE Support	IEEE 802.3af	

Connecting to Audio Input/Output

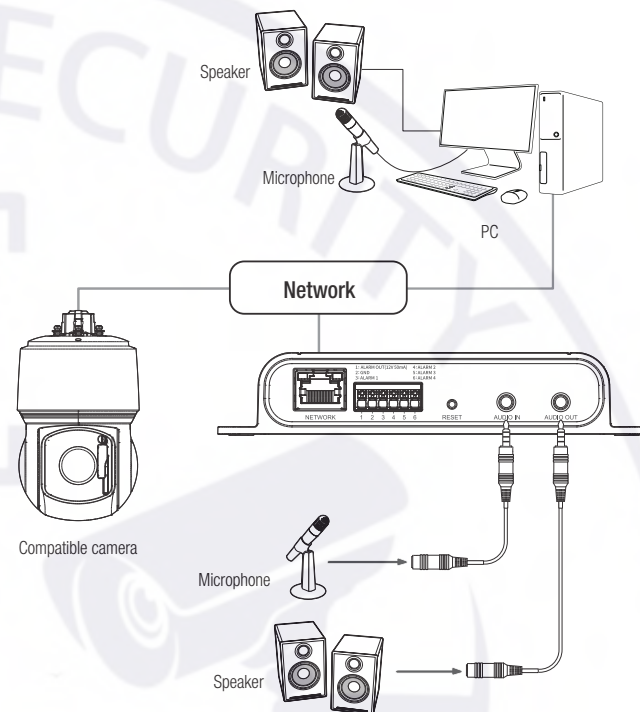

1. Connect the AUDIO IN port of the product with the microphone or LINE OUT port of the amplifier that the microphone is connected to.
2. Connect the AUDIO OUT port of the product with the speaker or LINE IN port of the amplifier that the speaker is connected to.
3. Check the specifications for audio input.

- **Audio Codec**
 - Audio In : G.711 PCM (Bit Rate: 64kbps / Sampling Frequency: 8kHz), G.726 ADPCM (Bit Rate: 16Kbps, 24Kbps, 32Kbps, 40Kbps / Sampling Frequency: 8kHz), AAC (Bit Rate: 48Kbps / Sampling Frequency: 16kHz)
- **Full duplex Audio**
- **Audio in** : Selectable (microphone/Line-in), Supported voltage: 2.5VDC (4mA), Input impedance: 2K Ohm
- **Audio out** : Line-out (3.5mm mono jack), Maximum output: 1Vms, Line out impedance : 600Ω

Connecting to the alarm I/O port

Connect the Alarm I/O cable to the corresponding port of the port box.

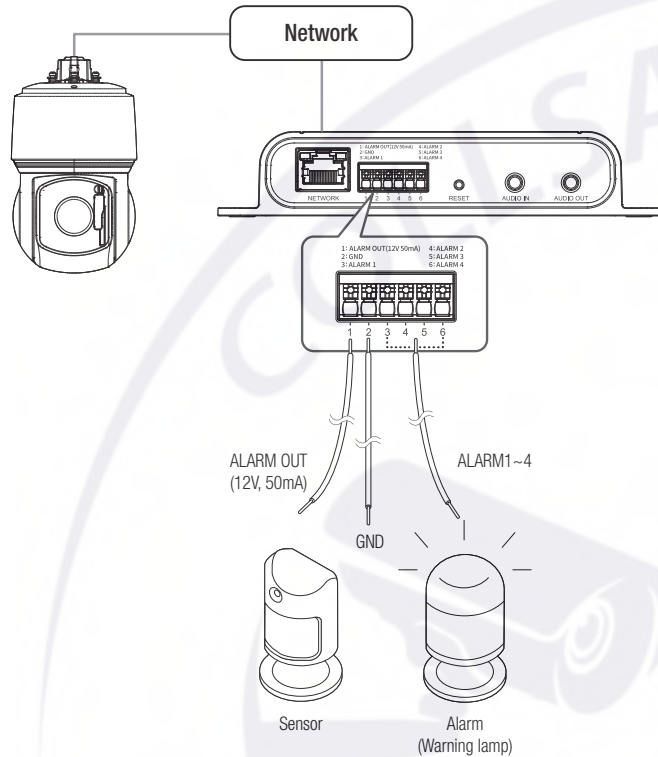

- ALARM OUT (12V, 50mA) : Connect to a sensor or warning light that uses electric power of 12V/50mA or below.
- GND : Common port for alarm in/output signal.
- ALARM 1~4 : These ports can be used as alarm input or output ports. If used as input ports, alarm input or day/night sensors can be connect to them. If used as output ports, alarm output signals can be connect to them.
※ Alarm I/O can be changed in the web viewer settings of the connected camera.

To connect the external sensor

Connect one of the 2 signal lines to the [ALARM 1~4] port (if you want this to be the input port) and the remaining one to the [GND] port.

Alarm In Wiring Diagram

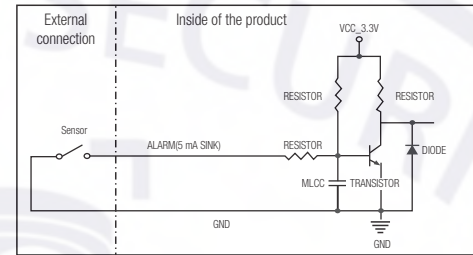

EST.

1998

WE SECURE YOUR LIFE

To connect the alarm out

If devices (e.g., flashing light and siren) that exceed the voltage and current specifications are connected by using the open collector method, it may cause malfunction.

Refer to the alarm out connection diagram below when connecting devices that exceed the voltage and current specifications.

Alarm Out Wiring Diagram

When the warning light/siren exceeds DC12V/50mA

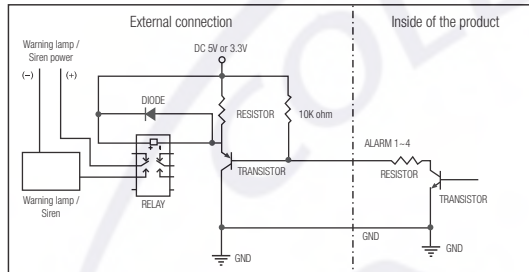

When the warning light/siren does not exceed DC12V/50mA

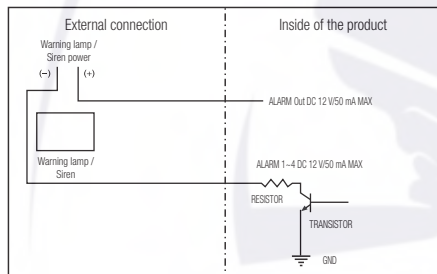

EST.

1998

You can set up the network settings according to your network configurations.

CONNECTING THE PRODUCT DIRECTLY TO LOCAL AREA NETWORKING

Connecting to the product from a local PC in the LAN

1. Launch an Internet browser on the local PC.
2. Enter the IP address of the product in the address bar of the browser.

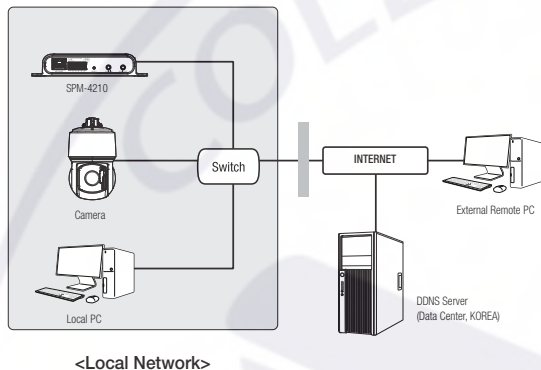

- A remote PC in an external Internet out of the LAN network may not be able to connect to the product installed in the intranet if the port-forwarding is not properly set or a firewall is set. In this case, to resolve the problem, contact your network administrator.
- By factory default, the IP address will be assigned from the DHCP server automatically. If there is no DHCP server available, the IP address will be set to 192.168.1.100. To change the IP address, use the Device Manager. For further details on Device Manager use, refer to "Using Device Manager".

USING DEVICE MANAGER

- Device manager program can be downloaded from <Support>-<Online Tool> menu at Hanwha Vision website (<https://www.HanwhaVision.com>).
- More instructions of Device Manager can be found at <Help> menu of the main page.

AUTOMATICALLY SEARCHING PRODUCT

If a product is connected to the same network of the PC where device manager is installed, you can find network product by using search function.

1. Click <Search> at the main page of device manager.
2. Check the product from the list.
 - Check MAC address at the sticker attached to the product.

CONFIGURING IP ADDRESS

If you want to change product network setting, <Login OK> sign must be displayed at <Status>. Click <Authentication> at the main page to log in.

Configuring Static IP

Manually insert and configure IP address & port information.

1. Click the product from the list that you want to change the IP setting.
2. Click <IP Assign> at the main page of device manager.
3. Select <Assign the following IP address>.
 - IP information of the product will be displayed as previously set.
4. Fill in IP & Port related categories.

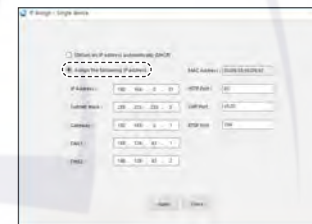

If not using a Broadband Router

For setting <IP Address>, <Subnet Mask>, and <Gateway>, contact your network administrator.

- HTTP Port : Used to access the product using the Internet browser, defaulted to 80.
- RTSP Port: A port that controls real-time streaming. The initial value is 554.

If using a Broadband Router

- IP Address : Enter an address falling in the IP range provided by the Broadband Router.
ex) 192.168.1.2~254, 192.168.0.2~254, 192.168.XXX.2~254
- Subnet Mask : The <Subnet Mask> of the Broadband Router will be the <Subnet Mask> of the product.
- Gateway : The <Local IP Address> of the Broadband Router will be the <Gateway> of the product.



- The settings may differ depending on the connected Broadband Router model. For more information, refer to the user manual of the applicable router.
- For more information about port forwarding of the broadband router, refer to "Port Range Forward (Port Mapping) Setup". (Page 13)

If the Broadband Router has more than one product connected

Configure the IP related settings and the Port related settings distinctly with each other.

ex)

Category		Product #1	Product #2
IP related settings	IP Address	192.168.1.100	192.168.1.101
	Subnet Mask	255.255.255.0	255.255.255.0
	Gateway	192.168.1.1	192.168.1.1
Port related settings	HTTP Port	8080	8081
	RTSP Port	554	555

- If the <HTTP Port> is set other than 80, you must provide the <Port> number in the address bar of the Internet browser before you can access the product.
ex) http://IP address : HTTP Port
http://192.168.1.100:8080

- Click [Apply] Button.
- If the success message is displayed, click [OK].

Configuring Dynamic IP

Receive IP address from DHCP

- Example of the Dynamic IP environment
 - If a Broadband Router, with products connected, is assigned an IP address by the DHCP server
 - If connecting the product directly to modem using the DHCP protocols
 - If IPs are assigned by the internal DHCP server via the LAN

- Click the product from the list that you want to change the IP setting.
- Click <IP Assign> at the main page of device manager.
- Select <Obtain an IP address automatically (DHCP)>.
- Click [Apply] button.
- If the success message is displayed, click [OK].



MANUALLY REGISTERING PRODUCT

If the product cannot be found using search function, the product can be registered remotely by manually inserting IP information, if the product is connected to external network.

- Click <Add Devices> - <Manually Add Device> at the main page of device manager.
- Insert the range of IP address that you search.
- Select the <Model Name> of the product that you register, and insert HTTP port, ID, and password.
- Click [Register] button.
- Check if product is registered.
 - Check MAC address at the sticker attached to the product.



EST.

1998

WE SECURE YOUR LIFE

AUTOMATICALLY CONFIGURING IP

1. Click the product from the list that you want to automatically configure the IP.
2. Click < + > at the main page of device manager.
 - Equipment Setting menu appears.
3. At the menu, click <Auto IP Configure>.
4. Click [Close] button.



PORT RANGE FORWARD (PORT MAPPING) SETUP

If you have installed a Broadband Router with a product connected, you must set the port range forwarding on the Broadband Router so that a remote PC can access the product in it.

Manual Port Range Forwarding

1. From the Setup menu of the Broadband Router, select <Applications & Gaming> - <Port Range Forward>. For setting the port range forward for a third-party Broadband Router, refer to the user guide of that Broadband Router.
2. Select <TCP> and <UDP Port> for each connected product to the Broadband Router. The number of each port to be configured to the IP router should be set according to the port number designated in <Setup> - <Basic> - <IP & Port> on the product web viewer.
3. When done, click [Save Settings]. Your settings will be saved.



- Port forwarding setting is an example of setting CISCO IP router.
- The settings may differ depending on the connected Broadband Router model. For more information, refer to the user manual of the applicable router.

Setting up Port Range Forward for several network products

- You can set a rule of Port Forwarding on the Broadband Router device through its configuration web page.
- A user can change each port using the product setting screen.

When Product#1 and Product#2 are connected to a router :

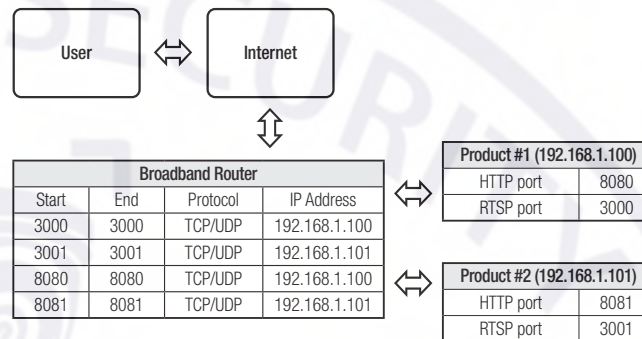

CONNECTING TO THE PRODUCT FROM A SHARED LOCAL PC

1. Run device manager. It will scan for connected products and display them as a list.
2. Double-click a product to access. The Internet browser starts and connects to the product.

- Access to the product can also be gained by typing the product's IP address in the address bar of the Internet browser.

CONNECTING TO THE PRODUCT

Normally, you would

1. Launch the Internet browser.
2. Type the IP address of the product in the address bar.
 - ex) • IP address (IPv4) : 192.168.1.100 → http://192.168.1.100 - the Login dialog should appear.
 - IP address (IPv6) : 2001:230:abcd:ffff:0000:0000:ffff:1111 → http://[2001:230:abcd:ffff:0000:0000:ffff:1111] - the Login dialog should appear.



If the HTTP port is other than 80

1. Launch the Internet browser.
2. Type the IP address and HTTP port number of the product in the address bar.
 - ex) IP address : 192.168.1.100:HTTP Port number(8080) → http://192.168.1.100:8080 - the Login dialog should appear.

PASSWORD SETTING

When you access the product for the first time, you must register the login password.



- For a new password with 8 to 9 digits, you must use at least 3 of the following: uppercase/lowercase letters, numbers and special characters. For a password with 10 to 15 digits, you must use at least 2 types of those mentioned.
 - Special characters that are allowed: ~!@#\$%^&*()_+=|{}?/
- For higher security, you are not recommended to repeat the same characters or consecutive keyboard inputs for your passwords.
- If you lost your password, you can press the **[RESET]** button to initialize the product. So, don't lose your password by using a memo pad or memorizing it.



LOGIN

Whenever you access the product, the login window appears. Enter the User ID and password to access the product.

1. Enter "**admin**" in the <User name> input box.
 - The administrator ID, "**admin**", is fixed and can not be changed.
2. Enter the password in the <Password> input field.
3. Click **[Sign in]**.
 - Once logged in, product setup screen appears.



SETTING UP PRODUCT

1. Access your product through web browser, then setup screen appears.
2. You can configure settings for the product's basic information, network, and system over the network.
3. Click <Help (?)> to view detailed descriptions of each function.

CONNECTING CAMERA WITH PRODUCT

To use the features of the product, you need to connect the camera with the product through camera setup.

1. Access the camera through web browser, and click <Event> → <I/O box> in the setup screen.
2. Click <Enable I/O box> to activate sub menus.
3. Enter the product's IP type, IP address, port number, etc. and then enter the password set for the product.
4. Once the camera is connected with the product, set the alarm and audio I/O appropriate for the installation environment.

TROUBLESHOOTING

PROBLEM	SOLUTION
I can't access the product from a web browser.	<ul style="list-style-type: none">• Check to make sure that the product's Network settings are appropriate.• Check to make sure that all network cables have been connected properly.• If connected using DHCP, verify that the product is able to acquire dynamic IP addresses without any problem.• If the product is connected to a Broadband Router, verify that port forwarding is properly configured.
The product connected to the network is not detected in the Device Manager program.	<ul style="list-style-type: none">• Turn off the firewall settings on your PC and then search the product again.



Any changes or modifications in construction of this device which are not expressly approved by the party responsible for compliance could void the user's authority to operate the equipment.

This device complies with part 15 of the FCC Rules. Operation is subject to the following two conditions: (1) This device may not cause harmful interference, and (2) this device must accept any interference received, including interference that may cause undesired operation.

This equipment has been tested and found to comply with the limits for a Class A digital device, pursuant to part 15 of the FCC Rules. These limits are designed to provide reasonable protection against harmful interference when the equipment is operated in a commercial environment. This equipment generates, uses, and can radiate radio frequency energy and, if not installed and used in accordance with the instruction manual, may cause harmful interference to radio communications. Operation of this equipment in a residential area is likely to cause harmful interference in which case the user will be required to correct the interference at his own expense.

- Reorient or relocate the receiving antenna.
- Increase the separation between the equipment and receiver.
- Connect the equipment into an outlet on a circuit different from that to which the receiver is connected.
- Consult the dealer or an experienced radio/TV technician for help.



Hanwha Vision cares for the environment at all product manufacturing stages, and is taking measures to provide customers with more environmentally friendly products.

The Eco mark represents Hanwha Vision's devotion to creating environmentally friendly products, and indicates that the product satisfies the EU RoHS Directive.



Correct Disposal of This Product (Waste Electrical & Electronic Equipment)

(Applicable in the European Union and other European countries with separate collection systems)

This marking on the product, accessories or literature indicates that the product and its electronic accessories (e.g. charger, headset, USB cable) should not be disposed of with other household waste at the end of their working life. To prevent possible harm to the environment or human health from uncontrolled waste disposal, please separate these items from other types of waste and recycle them responsibly to promote the sustainable reuse of material resources.

Household users should contact either the retailer where they purchased this product, or their local government office, for details of where and how they can take these items for environmentally safe recycling.

Business users should contact their supplier and check the terms and conditions of the purchase contract. This product and its electronic accessories should not be mixed with other commercial wastes for disposal.



Correct disposal of batteries in this product

(Applicable in the European Union and other European countries with separate battery return systems.)

This marking on the battery, manual or packaging indicates that the batteries in this product should not be disposed of with other household waste at the end of their working life. Where marked, the chemical symbols Hg, Cd or Pb indicate that the battery contains mercury, cadmium or lead above the reference levels in EC Directive 2006/66. If batteries are not properly disposed of, these substances can cause harm to human health or the environment.

To protect natural resources and to promote material reuse, please separate batteries from other types of waste and recycle them through your local, free battery return system.

COLLSAM SECURITY



EST.

1998

WE SECURE YOUR LIFE

Sales@collsam.com
(951)282-8707

[HTTPS://COLLSAM.COM](https://collsam.com)
Images May Not Reflect the Actual Product.
Design and specifications are subject to change without notice.

Support@collsam.com
(213)210-6744