

DH-PFM320D-US

12V 2A Power Adapter



Features

- Provides surge protection for sensitive equipment
- Visual indication helps identify power issues quickly
- Wide temperature range ensures the power adapter can handle extreme temperatures
- Accurate overcurrent and overvoltage protection protects equipment from damage
- CCC/CE/FCC/UL certification ensures the highest safety standards

Dimensions (mm/inch)

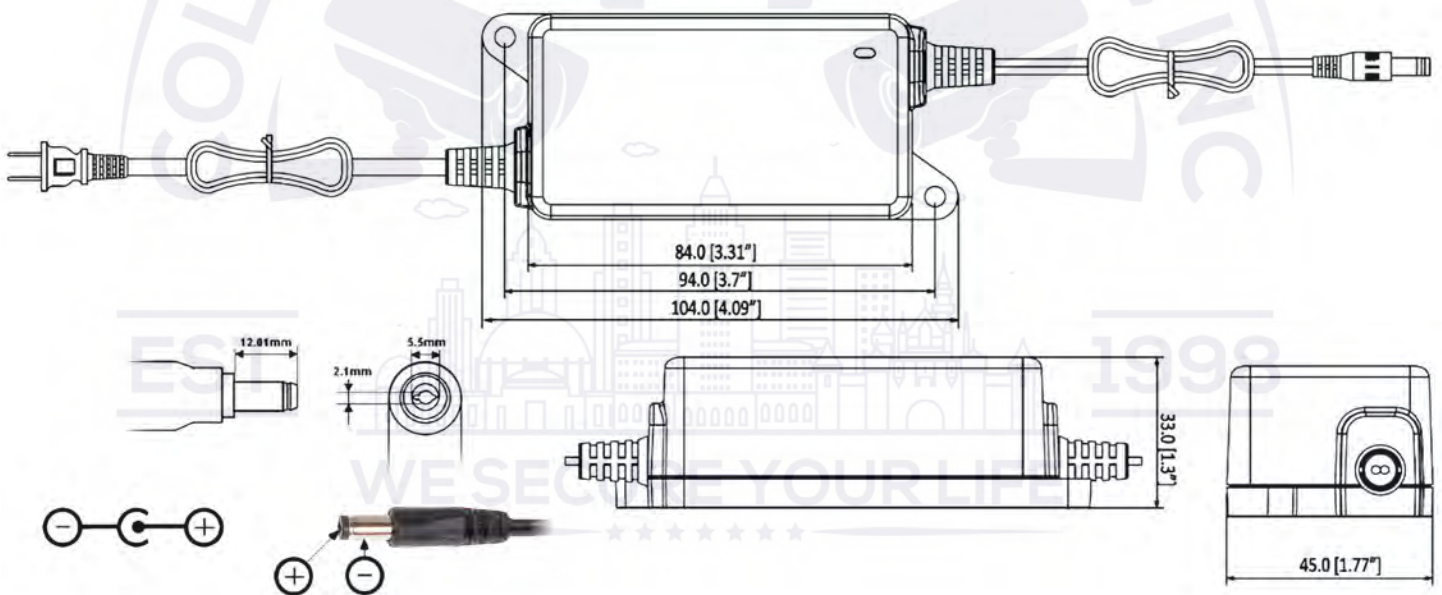

Technical Specifications

Model	DH-PFM320D-US
Electrical Specification	
Input	100~240V, 50/60Hz, 0.6A
Output	12V, 2A(+7% , -3%)
Protection/Environmental	
Protection	Surge protection, over temperature protection, over current, voltage load protection
	ESD: EN61000-4-2 ± 4kV Contact; ± 8kV Air
	Surge: EN61000-4-5" Combination Wave: Common Mode ±4KV (12 ohms); Differential Mode ±2kV (2 ohms)
Working Temperature	-30°C ~ +70°C (-22°F ~ +158°F)
Working Humidity	<95% RH
Physical Properties	
Weight	170g(0.37lb)
Dimension(Lxwxh)	104mmx45mmx33mm(4.09"x1.77"x1.3")
Installation Mode	Plane installation
Color	Black
Input Plug	2-pin North American plug
Outgoing Cord	AC wire: 50cm(19.69"), DC wire: 80cm(31.5")
DC Plug	Φ5.5mmxΦ2.1mmx12mm(Φ0.22"xΦ0.08"x0.47")
Safety Standards	
Certification	CE, FCC, UL-VI

