

---

# 5-inch In-ceiling Intelligent Speed Dome Installation Manual

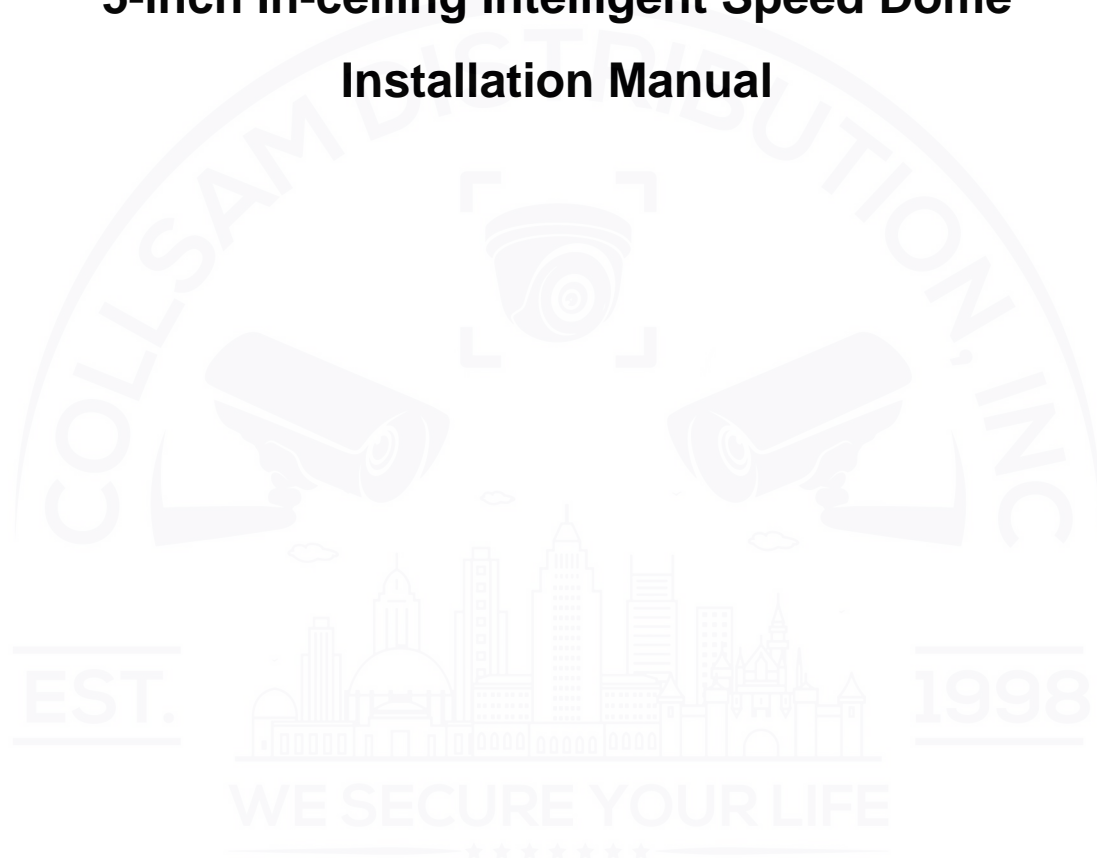

**Version 1.0.3**

---

# Table of Contents

<b>1</b>	<b>INSTALLATION PREPARATION</b> .....	<b>1</b>
1.1	Basic Requirements.....	1
1.2	Installation Check .....	1
1.3	Cable Preparation .....	1
1.3.1	Cable Lowest Specification Requirement.....	1
1.3.2	Select Needed Power Supply Cable According to Transmission Distance.....	2
<b>2</b>	<b>SPEED DOME INSTALLATION</b> .....	<b>3</b>
2.1	Check Accessories .....	3
2.2	Open Device .....	3
2.3	DIP Switch Setup.....	3
2.3.1	DIP Switch Location and Function.....	3
2.3.2	DIP Switch Setup .....	5
2.3.3	Address Setup .....	5
2.3.4	Baud Rate and Parity Setup .....	6
2.4	Terminal Matching Resistance Setup .....	7
2.5	Reset Button Location and SD Card Installation (Network Speed Dome) .....	8
2.6	Speed Dome Cable.....	9
2.6.1	Cable Description .....	9
2.6.2	Cable Connection .....	10
2.6.3	Alarm Cable Connection.....	10
2.6.4	Connect Speed Dome GND Cable.....	11
<b>3</b>	<b>IN-CEILING MOUNT</b> .....	<b>12</b>
3.1	Mounting Component and Dimension .....	12
3.2	Wall-mounted Bracket Installation Steps .....	12
3.2.1	Installation Conditions.....	12
3.2.2	Installation Steps .....	12
<b>4</b>	<b>APPENDIX I THUNDER PROOF AND SURGE PROTECTION (OUTDOORS)</b> .....	<b>17</b>

---

4.1	Lightning Protection (Indoors) .....	17
5	APPENDIX II ABOUT RS485 BUS .....	19
5.1	RS485 Bus Main Feature .....	19
5.2	RS485 Bus Transmission Distance .....	19
5.3	The Problem in Practical Use .....	19
5.4	RS485 Bus FAQ .....	20
6	APPENDIX III THE 24V AC WIRE GAUGE AND TRANSMISSION DISTANCE RELATIONSHIP SHEET .....	21
7	APPENDIX IV 12V DC WIRE GAUGE AND TRANSMISSION DISTANCE RELATIONSHIP SHEET .....	22
8	APPENDIX V WIRE GAUGE REFERENCE SHEET .....	23

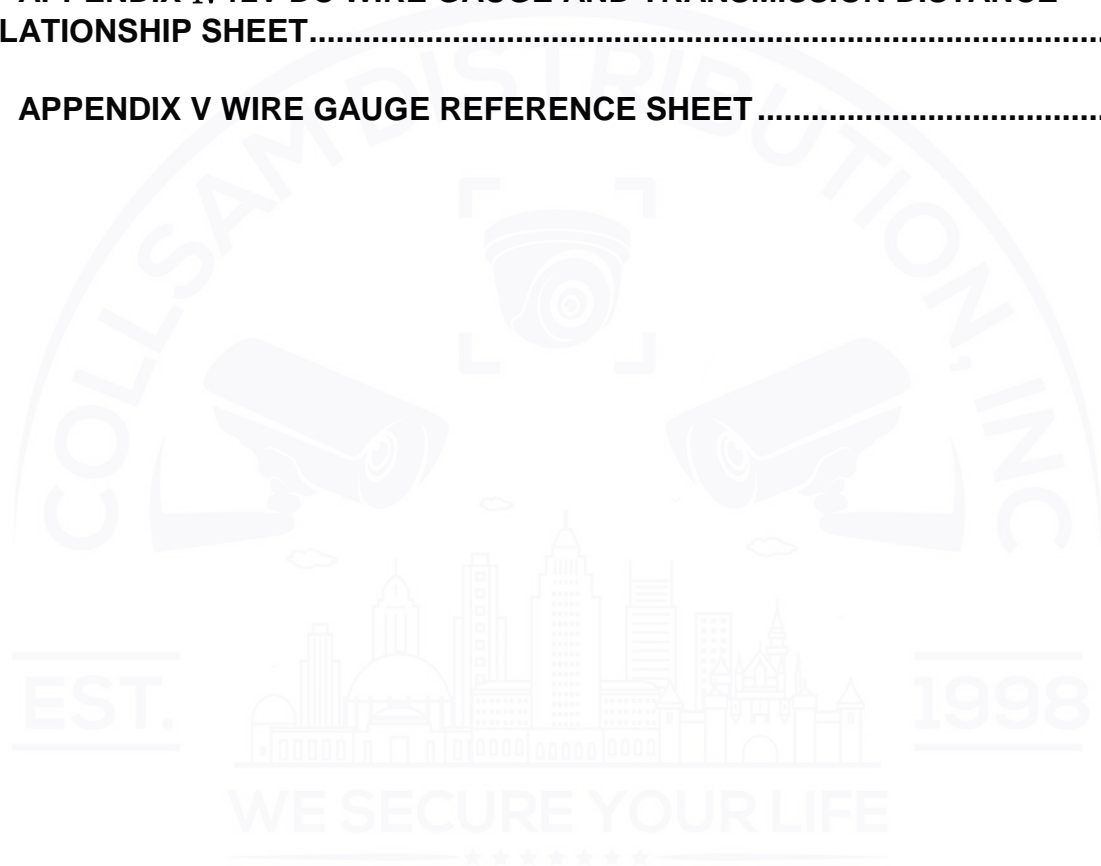

---

## Welcome

Thank you for purchasing our speed dome!

**Please read the following safeguards and warnings carefully before you install or use the product!**



---

# Important Safeguards and Warnings

## 1. Qualified Engineer Needed

- The installation engineer or maintenance engineer shall have corresponding CCTV system installation certificate or maintenance qualification certificate.
- The installation engineer or maintenance engineer shall have qualification certificate for work at height.
- The installation engineer or maintenance engineer shall have the basic knowledge and operation technique for low-voltage cable layout and low-voltage electronic cable connection.
- Please read the installation manual carefully and keep it well for future reference,
- We are not liable for any problems caused by unauthorized modifications or attempted repair.

## 2. Lifting Appliance Requirement

- Please select the proper speed dome installation mode and use the lifting appliances at the safety environment.
- The lifting appliances shall have the enough capacity to reach the installation height.
- The lifting appliances shall have safe performance.

**The precaution measures include two types: Warning and Note.**

- **Warning:** It is to alert you there is an optional risk of death or series injury!
- **Note:** It is to alert you there is an optional risk of damage or property loss!

## Warning

1. All installation and operation here should conform to your local electrical safety codes. We assume no liability or responsibility for all the fires or electrical shock caused by improper handling or installation.
2. Be sure to use all the accessories (such as power adapter) recommended by manufacturer.
3. Do not connect several speed domes to one power adapter. It may result in overheat or fire if it exceeds the rated load.
4. Before you connect the cable, install or uninstall, or begin the daily maintenance work, please turn off the power and unplug the power cable.
5. Please make sure the produce is secure firmly on the wall or the ceiling.
6. Please turn off the power and unplug the power cable, If there is any smoke, disgusting smell, or noise. Please contact your local retailer or customer service centre for help.

- 
7. All the examination and repair work should be done by the qualified service engineers. We are not liable for any problems caused by unauthorized modifications or attempted repair.

## Note

### 1. Safety Transportation

- Heavy stress, violent vibration or water splash are not allowed during transportation, storage and installation.
- This series product must use split type package during the transportation.
- We are not liable for any damage or problem resulting from the integrated package during the transportation.

### 2. When device is malfunction

Shut down the device and disconnect the power cable immediately if there is smoke, abnormal smell or abnormal function. Please contact your local retailer ASAP.

### 3. Do not try to dismantle or modify the device

- There is risk of personal injury or device damage resulting from opening the shell.
- Please contact your local retailer if there is internal setup or maintenance requirement.
- We are not liable for any problems caused by unauthorized modifications or attempted repair.

### 4. Do not allow other object falling into the device

- Please make sure there is no metal or inflammable, explosive substance in the speed dome.
- The above mentioned objects in the device may result in fire, short-circuit or damage.
- Please shut down the device and disconnect the power cable if there is water or liquid falling into the camera. Please contact your local retailer ASAP.
- Please pay attention to the camera. Avoid the sea water or rain to erode the camera.

### 5. Handle carefully

Do not allow this series product fall down to the ground.  
Avoid heavy vibration.

### 6. Installation Environment Requirement

- This series speed dome should be installed in a cool, dry place away from direct sunlight, inflammable, explosive substances and etc.
- This series product shall be away from the strong electromagnetism radiant, please keep it away from wireless power, TV transmitter, transformer and etc.

### 7. Daily Maintenance

- Please use the soft cloth to clean dust on the shell, or you can use soft cloth with cleaning liquid to clean the shell and then use soft cloth to make it dry.

- 
- Do not use gasoline, dope thinner or other chemical material to clean the shell. It may result in shell transfiguration or paint flake.
  - Do not allow the plastic or rubber material to touch the shell for a long time. It may result in paint flake.



---

# 1 INSTALLATION PREPARATION

## 1.1 Basic Requirements

- All installation and operation here should conform to your local electrical safety codes, fire prevention laws and some related regulations.
- Make sure if the application scene of the speed dome conforms to the installation requirements. Please contact your dealer if you have any questions.
- Please use the product according to the operating environment.
- Please keep the original packing material well after opening the package; you can use original packing material to pack the speed dome and send it back for maintenance in case problems occur.

## 1.2 Installation Check

- Make sure the installation site has enough space to hold the product and its mounting components.
- Please make sure the ceiling or wall can sustain 8X weight of the speed dome and its mounting components.
- Please make sure the wall is thick enough to install expansion bolts (Users need to purchase separately).
- It needs to guarantee the installation height shall be more than 6m if it is the intelligent tracking speed dome or laser speed dome.

## 1.3 Cable Preparation

Please select the specification of the needed video cable and video coaxial cable according to the transmission distance.

### 1.3.1 Cable Lowest Specification Requirement

- 75 ohm.
- Full cable with copper conductor.
- 95% knitted copper shield.
- Please refer to appendix II for RS485.

International Model	Max Transmission Distance (Ft\M)
RG59/U	750Ft/229M
RG6/U	1,000Ft/305M
RG11/U	1,500Ft/457M

#### Note

The above can be applied to analog speed dome and network speed dome.

International Model	Max Transmission Distance (M\Ft)
SYV-75-3	720P(25fps\30fps): 500M/1640Ft
	720P(50fps\60fps): 300M/984Ft
	1080P(25fps\30fps): 300M/984Ft

---

**Note**

The above can be applied to HDCVI speed dome.

**1.3.2 Select Needed Power Supply Cable According to Transmission Distance**

Refer to appendix III for AC 24V power supply device.

Refer to appendix IV for DC 12V power supply device.



---

## 2 SPEED DOME INSTALLATION

### 2.1 Check Accessories

Before the installation, please check the accessories one by one according to the packing list. Please make sure all the components listed are included.

### 2.2 Open Device

Open the package and then take out the device, which is shown in Figure 2-1.

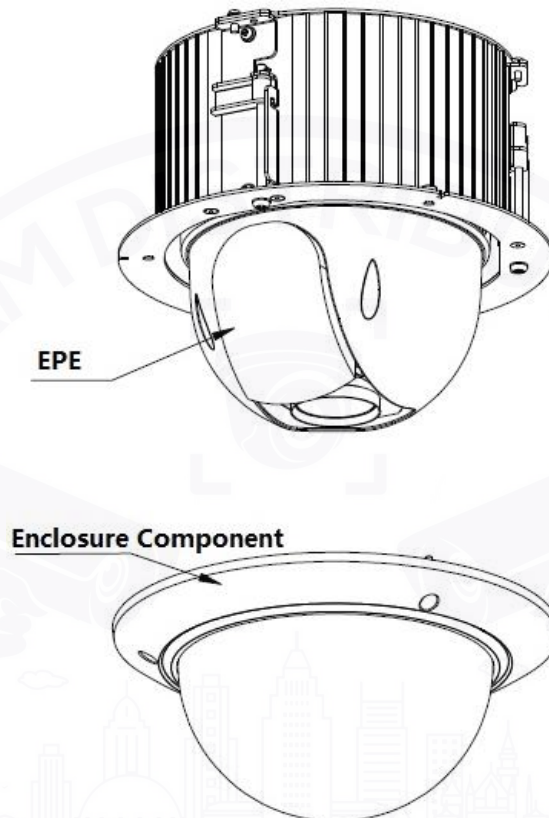

Figure 2-1

### 2.3 DIP Switch Setup

The corresponding functions of DIP switch for analog speed dome and HDCVI speed dome are different, which will be respectively introduced below.

#### 2.3.1 DIP Switch Location and Function

Use screwdriver to dismantle the module enclosure and then you can see the DIP switch, which is shown in Figure 2-2.

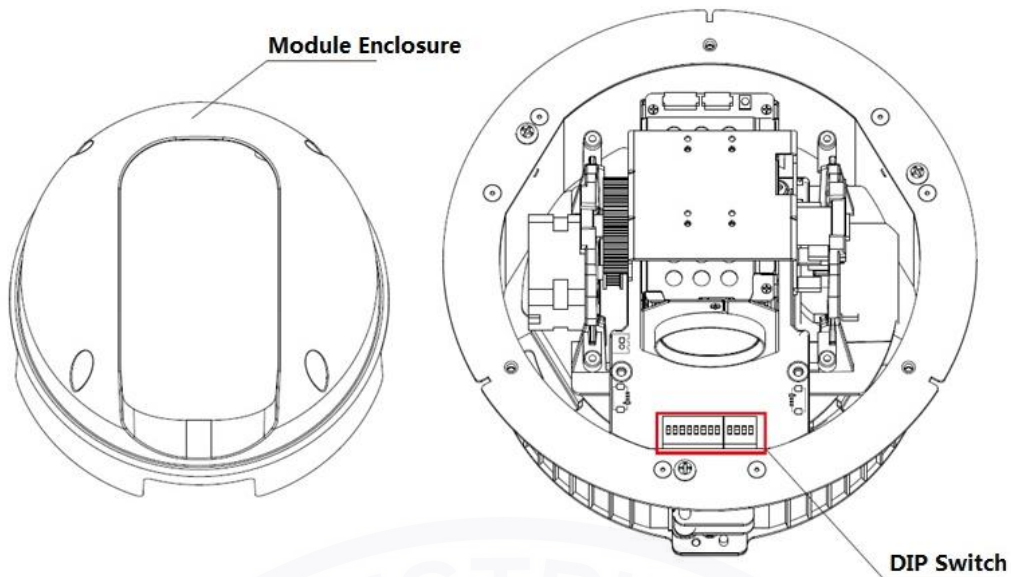

Figure 2-2

### 2.3.1.1 Analog Speed Dome

You can see there are two DIP switches on the PTZ after opening the speed dome, the two DIP switches are used to set the parameters of address, baud rate and parity, the location of DIP switch is shown in Figure 2-3.

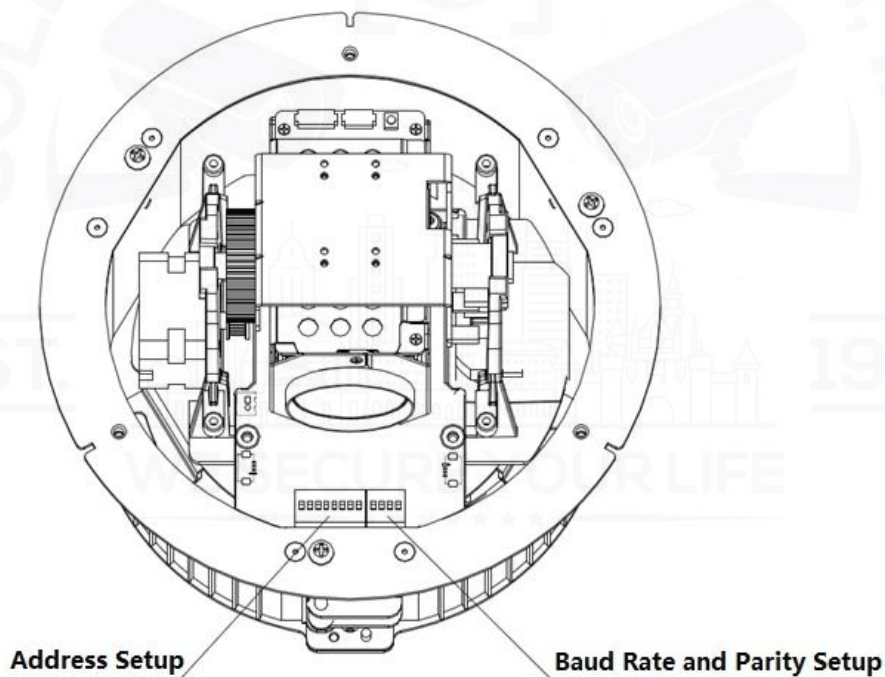

Figure 2-3

### 2.3.1.2 HDCVI Speed Dome

You can see there are two DIP switches on the PTZ after opening the speed dome, which are used to set address and baud rate of the speed dome. The location of DIP switch is shown in Figure 2-4.

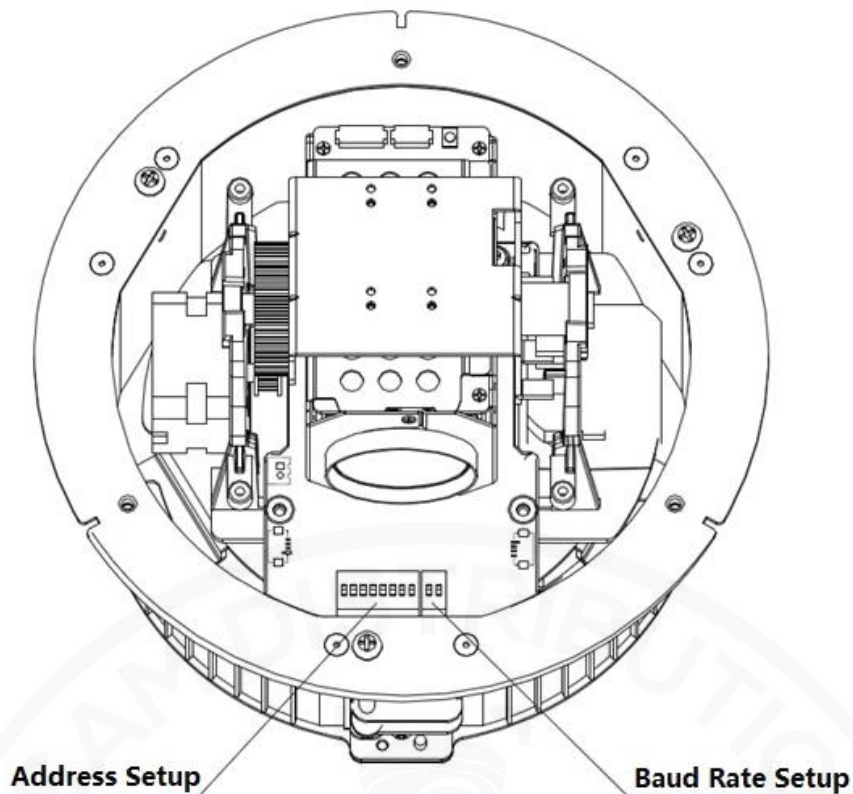

Figure 2-4

### 2.3.2 DIP Switch Setup

Before you control the speed dome, please set the speed dome address number, baud rate, and parity. The speed dome will respond to its control command after completing all these settings.

#### Note

- As for wall-mounted speed dome, it has to install transparent dome enclosure back in place after taking out EPE and setting DIP switch well.
- It has to cut off the power and restart the device to make new settings valid after some relevant information has been set again.

The two DIP switches on the PTZ are used to confirm the parameters of speed dome address, baud rate and parity. When you switch ON as 1, then 1 is the lowest bit and 8 is the highest bit in address setting dip switch; for baud rate and parity setting, 1 is the lowest bit and 4 is the highest bit.

#### Note

Please be noted that the speed dome can self-adapt to the industrial standard protocol, PELCO-D and PELCO-P, the control protocol doesn't need to be set via dip switch setting.

### 2.3.3 Address Setup

The speed dome can use DIP switch to set address number, the encoding mode adopts binary coding system. 1 to 8 is valid bit, and the highest address bit is 255. You can refer to Figure 2-5 for the address label, please refer to Table 2-1 for the setting of address bit.

1	2	3	4	5	6	7	8
Address							

Figure 2-5

Address	1	2	3	4	5	6	7	8
1	OFF	OFF	OFF	OFF	OFF	OFF	OFF	OFF
1	ON	OFF	OFF	OFF	OFF	OFF	OFF	OFF
2	OFF	ON	OFF	OFF	OFF	OFF	OFF	OFF
3	ON	ON	OFF	OFF	OFF	OFF	OFF	OFF
4	OFF	OFF	ON	OFF	OFF	OFF	OFF	OFF
5	ON	OFF	ON	OFF	OFF	OFF	OFF	OFF
6	OFF	ON	ON	OFF	OFF	OFF	OFF	OFF
7	ON	ON	ON	OFF	OFF	OFF	OFF	OFF
8	OFF	OFF	OFF	ON	OFF	OFF	OFF	OFF
.....	.....							
254	OFF	ON	ON	ON	ON	ON	ON	ON
255	ON	ON	ON	ON	ON	ON	ON	ON

Table 2-1

### 2.3.4 Baud Rate and Parity Setup

The functions which need to be set between analog speed dome and HDCVI speed dome will be introduced separately below.

#### 2.3.4.1 Analog Speed Dome

It is to set speed dome baud rate and parity. Bit 1 and 2 are used to set baud rate in the dip bit from 1 to 4, bit 3 and 4 are used to set parity. Refer to Figure 2-6 for the label and please refer to Table 2-2 and Table 2-3 for baud rate and parity setup.

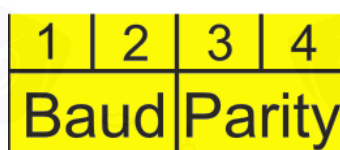

Figure 2-6

1	2	Baud Rate
OFF	OFF	9600bps
ON	OFF	4800bps
OFF	ON	2400bps
ON	ON	1200bps

Table 2-2

3	4	Parity
OFF	OFF	NONE
ON	OFF	EVEN
OFF	ON	ODD
ON	ON	NONE

Table 2-3

#### 2.3.4.2 HDCVI Speed Dome

It is to set speed dome baud rate. Bit 1 and 2 are used to set baud rate. Please refer to Figure 2-7 for the label, refer to Table 2-4 for baud rate setup.



Figure 2-7

1	2	Baud Rate
OFF	OFF	9600bps
ON	OFF	4800bps
OFF	ON	2400bps
ON	ON	1200bps

Table 2-4

## 2.4 Terminal Matching Resistance Setup

There is terminal resistance 120Ω on the main board. There are two modes: See Figure 2-8.

	1-2	2-3
120 Ω	ON	OFF

Figure 2-8

The factory default setup is shown as in Figure 2-9. Right now, the jumper (Connection board) is on the pin 2 and pin 3. The 120Ω resistance does not connect to the device.

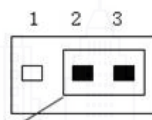

Factory Default Jump Setup  
(120Ω Resistance Unconnected)

Figure 2-9

If you want to connect the 120Ω resistance, please remove the jumper from the pin 2 and pin 3 and connect to pin 1 and pin 2. Now the 120Ω is connected to the circuit. See Figure 2-10.

1 2 3

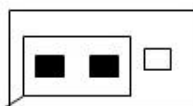

Jumper Setup  
(120Ω Resistance Connected)

Figure 2-10

---

## 2.5 Reset Button Location and SD Card Installation (Network Speed Dome)

After opening the speed dome, you can see there is a reset button on the PTZ mainboard shown as in Figure 2-11. The RESET button is used to reset network system.

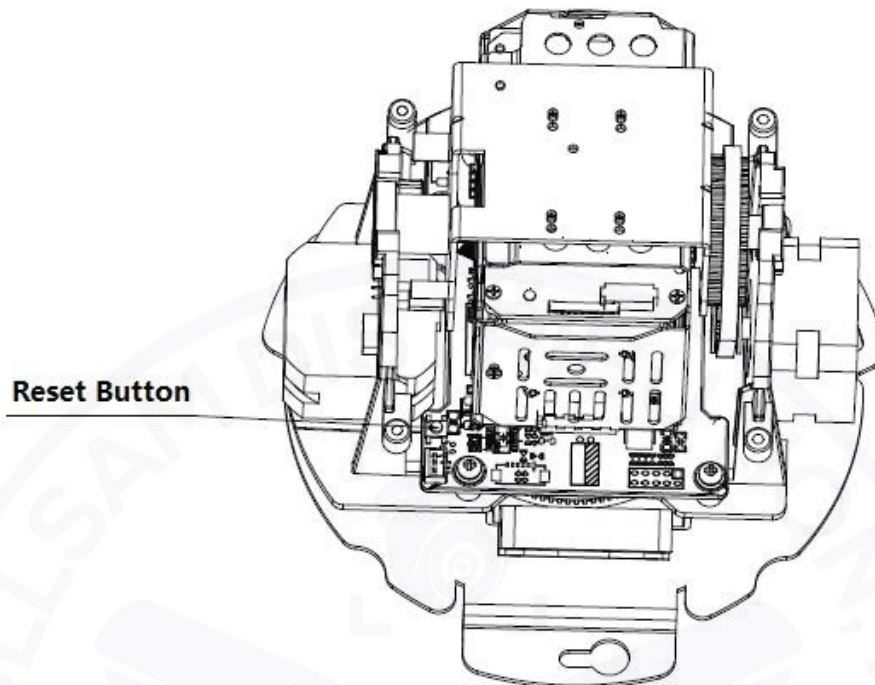
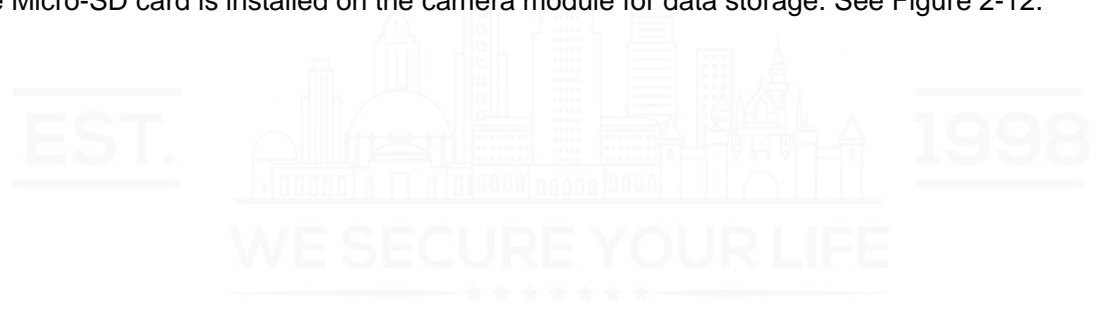

Figure 2-11

The Micro-SD card is installed on the camera module for data storage. See Figure 2-12.



---

### SD Card Location

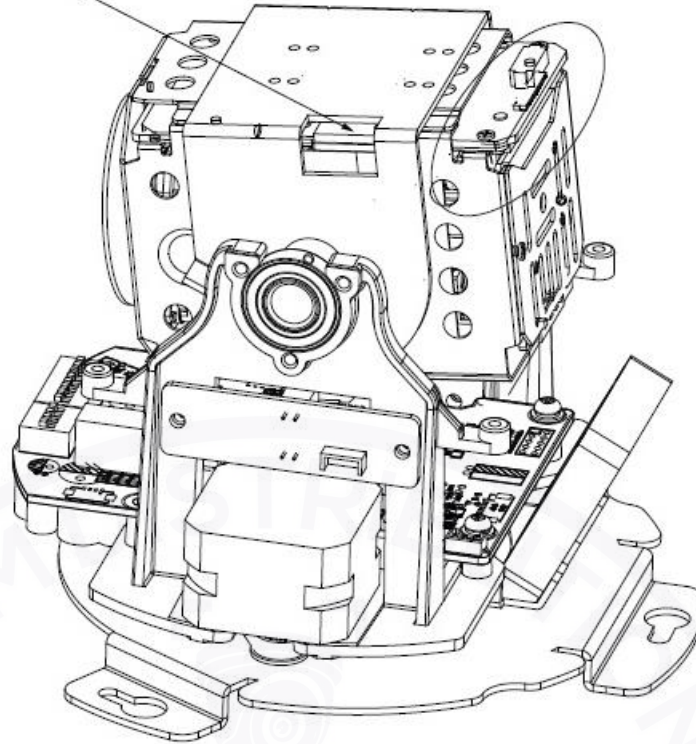

Figure 2-12

#### Note

- For some camera modules, the location of SD card slot is in the black circle which is shown in Figure 2-12.
- Please contact the technical support of our company if you have any questions.

## 2.6 Speed Dome Cable

### 2.6.1 Cable Description

The camera is equipped with a multi-functional combination cable by default, which includes power cable, video cable, audio cable, RS485 control cable, alarm cable, network cable, high-frequency cable and optical fiber cable etc. The cable detail is shown in Figure 2-13.

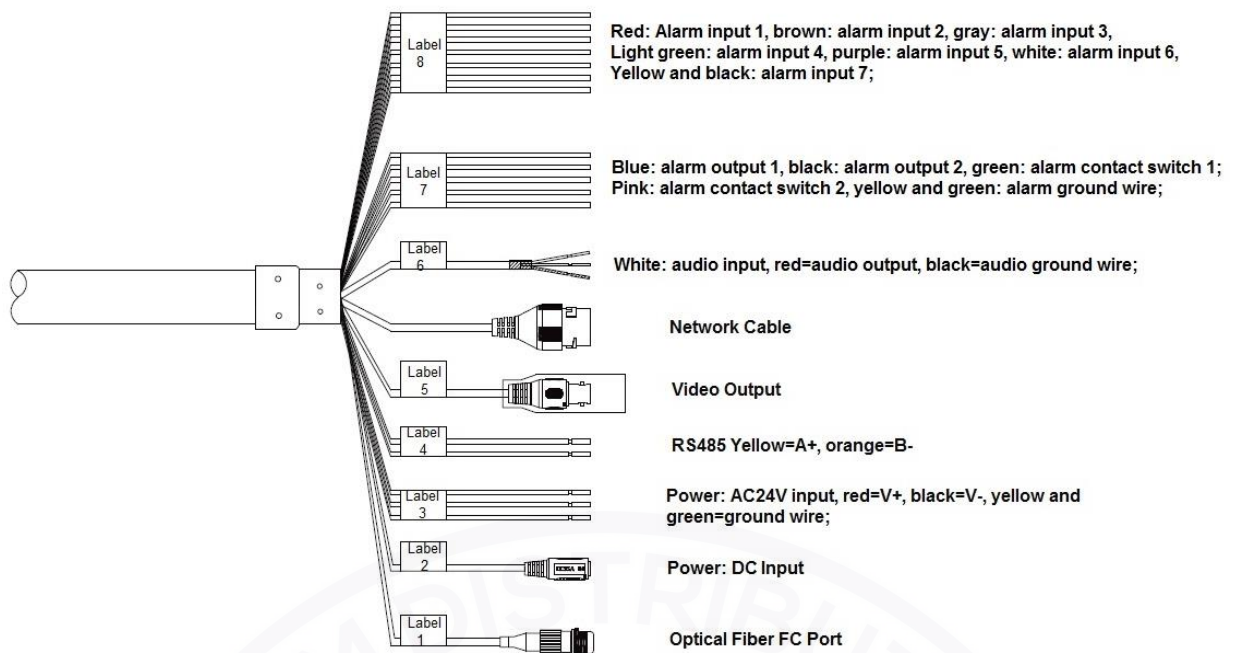

Figure 2-13

#### Note

Different models have different cable combinations; please refer to the actual cable combination for more details. The cable combination is the most comprehensive example shown in the figure above.

It is prohibited to pull the cable to lift the speed dome when moving the device.

### 2.6.2 Cable Connection

Buckle the safety hook of speed dome on the quick mount connector; connect the integrated cable reserved by wall-mounted bracket to the corresponding power cable, video cable, audio cable, RS485 control cable, alarm cable, network cable, high-frequency cable and optical fiber cable etc. of the multi-functional combination cable of the speed dome (according to requirement), and then use insulated rubber tape to twine the cable connection well to make it waterproof.

#### Note

- The video port is covered with heat-shrinkable tube with high shrinkage ratio, it needs to heat and shrink the tubes on both sides after the video port is well connected, which is to make sure the video port is moistureproof and waterproof.
- During actual installation, make sure the wire diameter of the cable which is to connect to RS485 control cable can't be too big; otherwise it will affect the control effect. Please refer to appendix 2 RS485 bus for relevant introduction.

### 2.6.3 Alarm Cable Connection

The alarm cable connection mode and config steps are shown as follows:

#### Step 1

Connect alarm input device to the ALARM IN and ALARM GND of the user cable.

#### Step 2

Connect alarm output device to the ALARM OUT and ALARM COM of the user cable, alarm output is the relay switch output.

---

**Step 3**

Open the device WEB interface, make corresponding settings to the alarm input and output device in "Setup > Event > Alarm Setup". The alarm input of WEB is corresponding to the alarm input of the user cable. It is to set the corresponding NO and NC output according to the high and low level signal generated by alarm input device when alarm triggers.

**Step 4**

Set the alarm output situation of user cable on the WEB.

**2.6.4 Connect Speed Dome GND Cable**

Connect the power line YELLOW & GREEN of the combination cable to the lightning protection device, and make sure the lightning protection device is well grounded.



---

## 3 IN-CEILING MOUNT

### 3.1 Mounting Component and Dimension

The in-ceiling bracket and main dome body are shown in Figure 3-1.

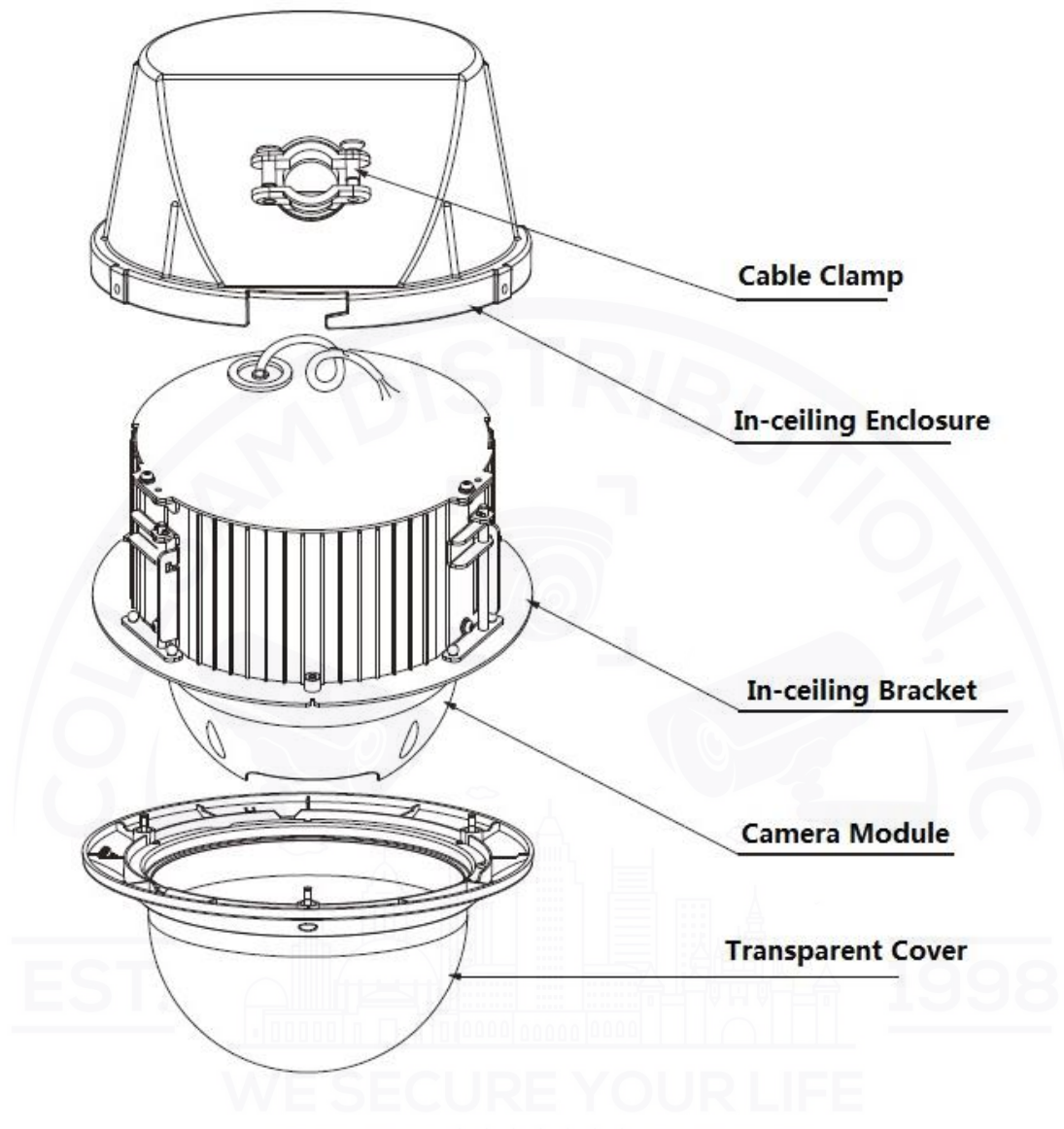

Figure 3-1

### 3.2 Wall-mounted Bracket Installation Steps

#### 3.2.1 Installation Conditions

The in-ceiling speed dome can be installed on the hard construction ceiling in indoor environment.

The ceiling needs to meet the following conditions:

- The thickness of ceiling shall be between 10mm and 40mm.
- The ceiling can at least sustain the 8x weight of the speed dome, bracket and the accessories.

#### 3.2.2 Installation Steps

---

**Step 1**

As it is shown in Figure 3-2, stick the punching position map after the mounting location is confirmed, and then take it as template to draw punching position on the ceiling and dig holes.

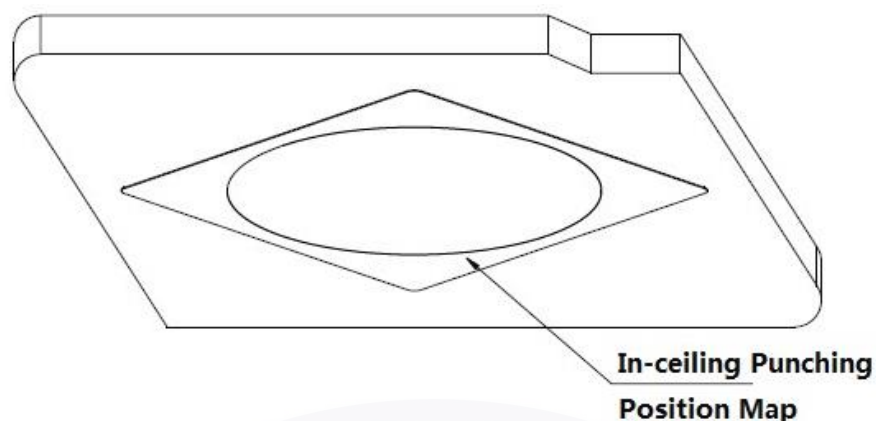

Figure 3-2

**Step 2**

Use screwdriver to loosen the screw on the cable clamp of the in-ceiling enclosure, which is shown in Figure 3-3.

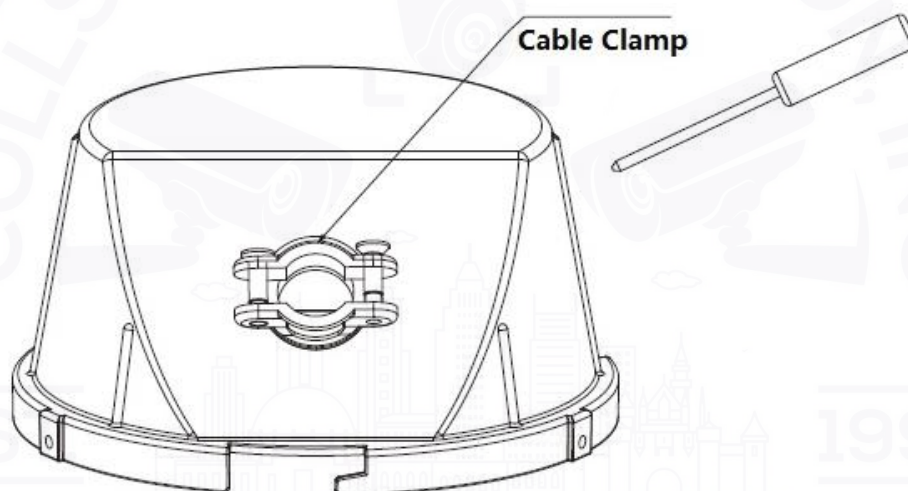

Figure 3-3

**Step 3**

Pull the cable out from the wall; insert it into the in-ceiling enclosure via cable clamp, and then use screwdriver to tighten the screw on the cable clamp, which is shown in Figure 3-4.

**Note**

The cable which is pulled out from wall needs to cover a fireproof metal tube that meets UL2043 standard.

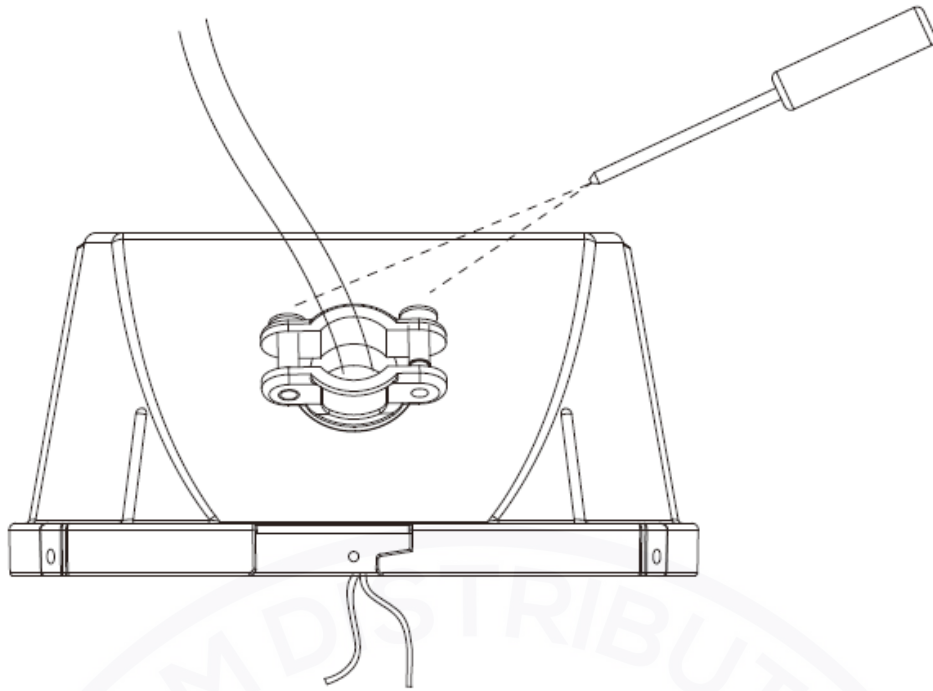

Figure 3-4

**Step 4**

Connect the speed dome cable to the wall cable well and make it waterproof, which is shown in Figure 3-5.

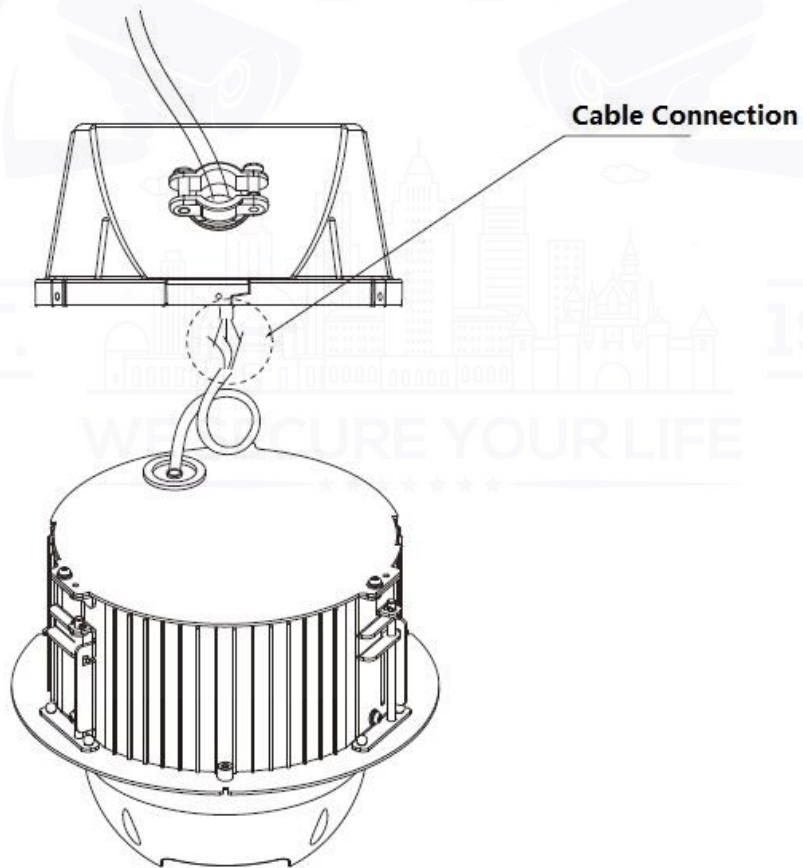

Figure 3-5

---

### Step 5

Rotate the enclosure clockwise to make the J-shaped hook fasten the flange of the camera module; Use screwdriver to tighten the screws on the enclosure edge, which is to fix the enclosure together with the camera module. Refer to Figure 3-6 for more details.

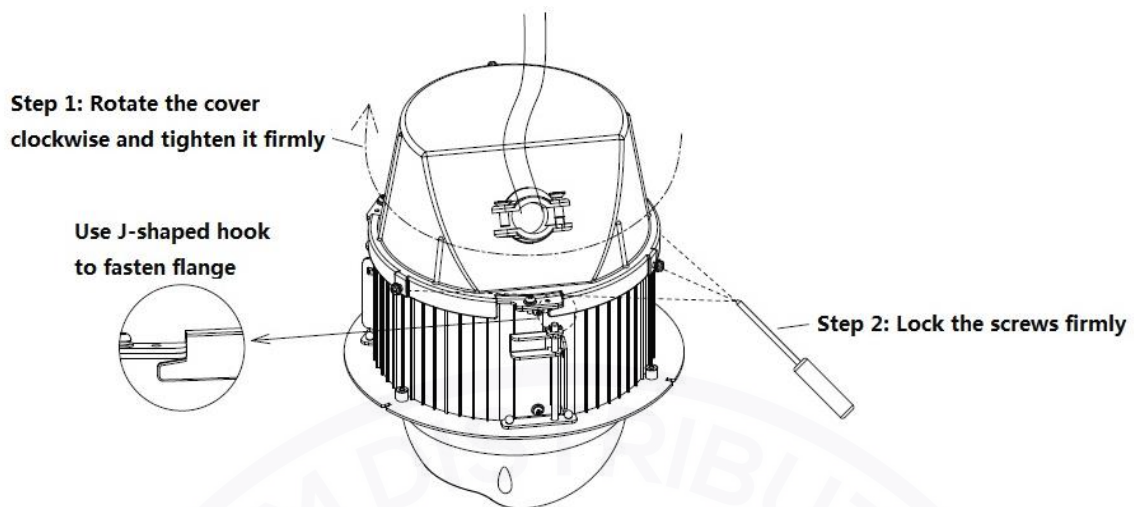

Figure 3-6

### Step 6

Place the speed dome into the mounting holes which have been well punched, use screwdriver to rotate the three studs on the speed dome edge clockwise, which is to make three clamps on the speed dome side unfolded and lower it to the bottom to clamp ceiling. Refer to Figure 3-7 for more details.

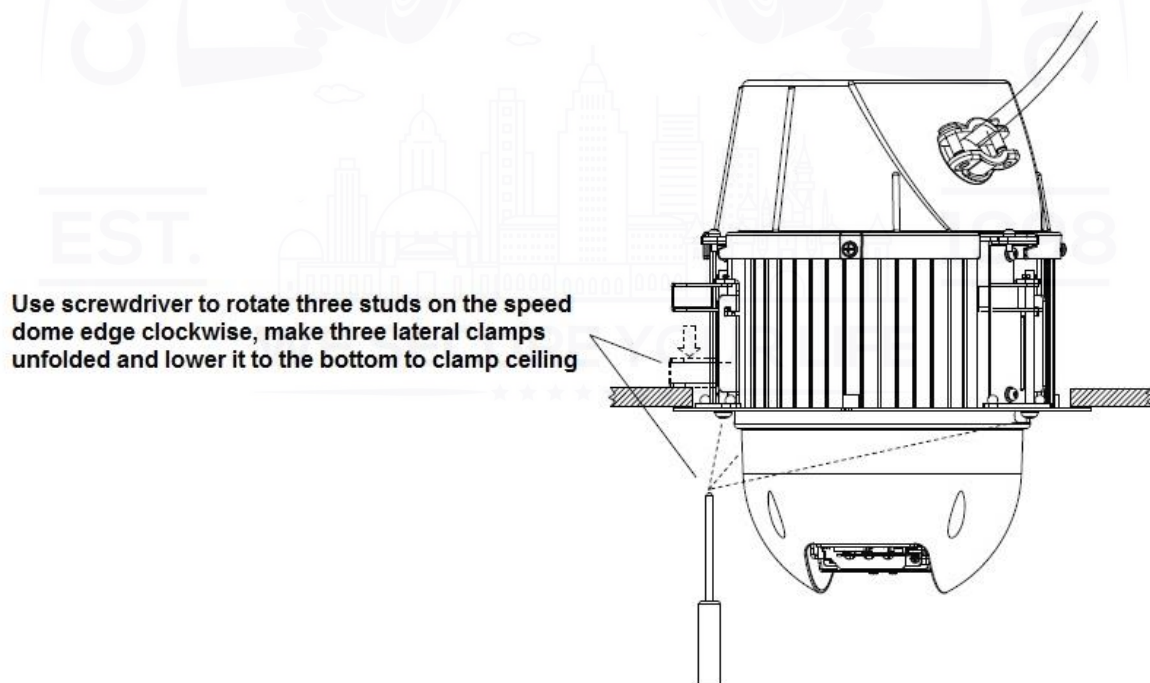

Figure 3-7

### Step 7

Use three screws to fix the in-ceiling decoration cover component to the in-ceiling bracket component, and then tighten the screws. Refer to Figure 3-8 for more details.

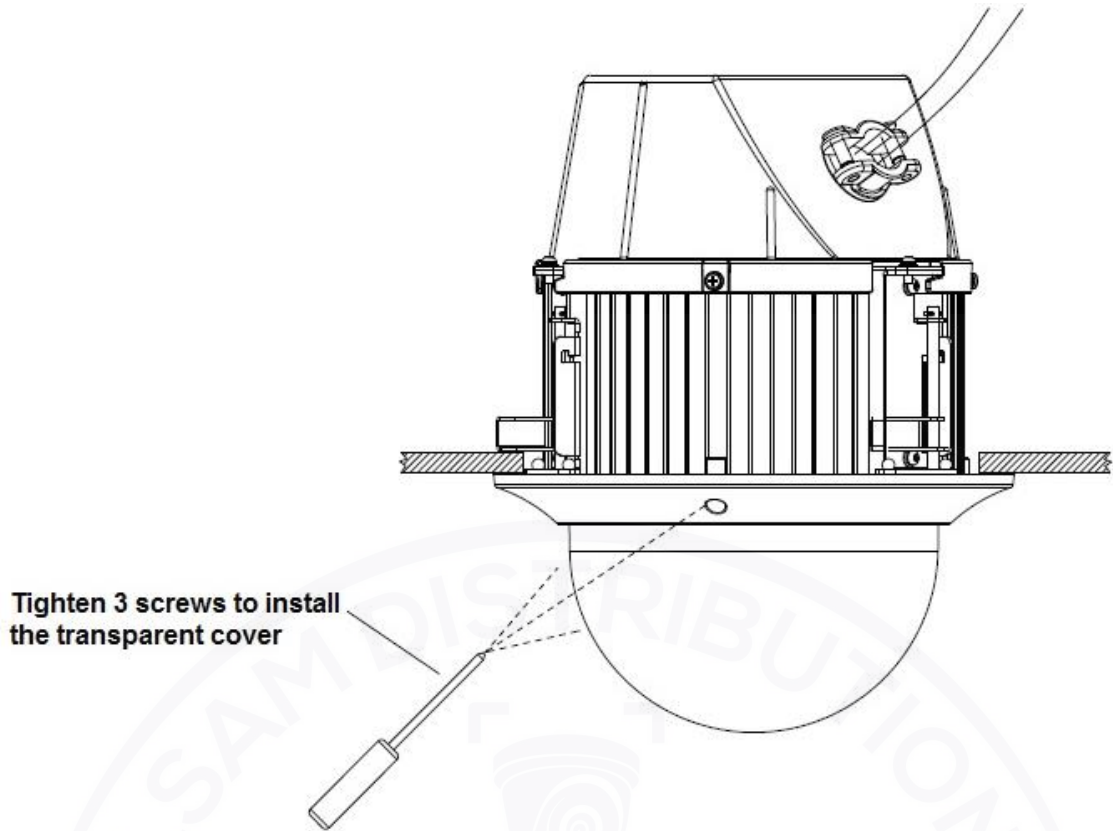

Figure 3-8

So far, the installation has been completed, which is shown in Figure 3-9.

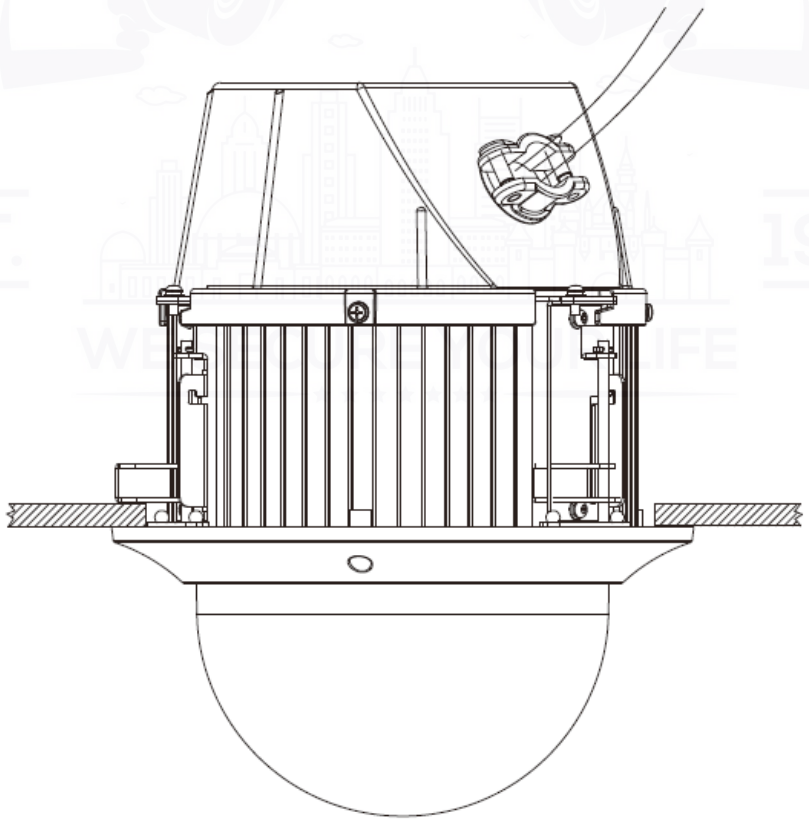

Figure 3-9

## 4 APPENDIX I THUNDER PROOF AND SURGE

### PROTECTION (Outdoors)

This series speed dome adopts TVS lightning protection technology. It can effectively prevent damages from various pulse signals below 6000V, such as sudden lightning and surge. While maintaining your local electrical safety code, you still need to take necessary precaution measures when installing the speed dome in the outdoor environment.

- The distance between the signal transmission cable and high-voltage device (or high-voltage cable) shall be at least 50 meters.
- Outdoor cable layout shall go under the penthouse if possible.
- For vast land, please use sealing steel tube under the land to implement cable layout and connects one point to the earth. Open floor cable layout is forbidden.
- In area of strong thunderstorm hit or near high sensitive voltage (such as near high-voltage transformer substation), you need to install additional high-power thunder protection device or lightning rod.
- The thunder protection and earth of the outdoor device and cable shall be considered in the building whole thunder protection and conform to your local national or industry standard.
- System shall adopt equal-potential wiring. The earth device shall meet anti-jamming and at the same time conforms to your local electrical safety code. The earth device shall not short circuit to N (neutral) line of high voltage power grid or mixed with other wires. When connect the system to the earth alone, the earth resistance shall not be more than  $4\Omega$  and earth cable cross-sectional area shall be no less than  $25\text{ mm}^2$ . See Figure 4-1

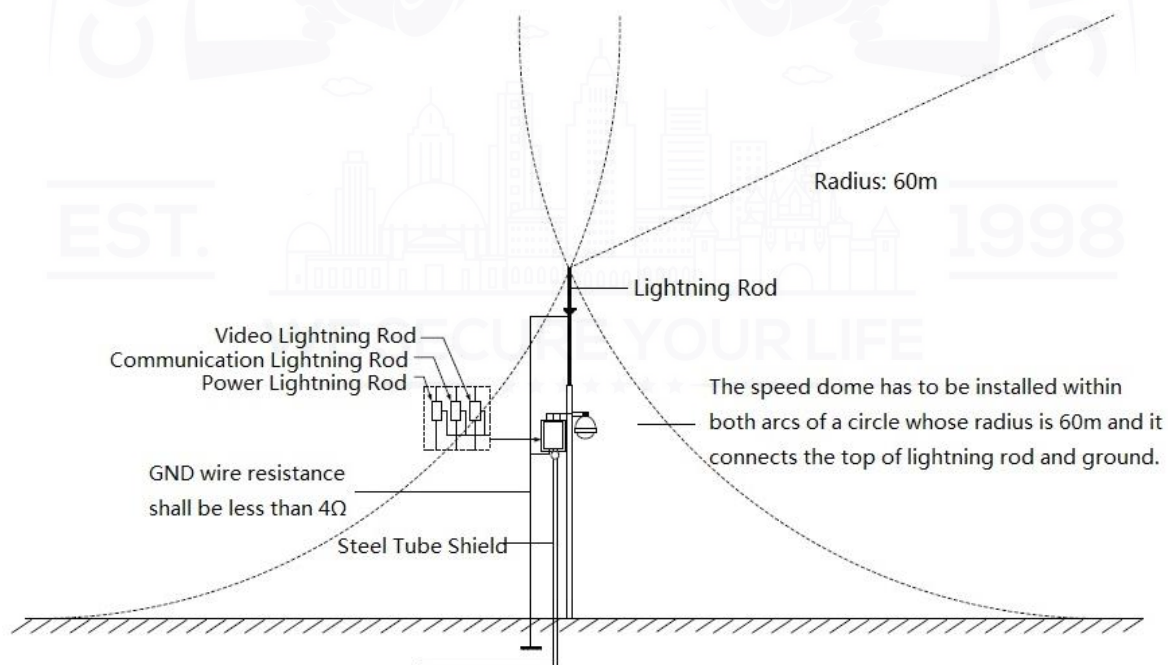

Figure 4-1

#### 4.1 Lightning Protection (Indoors)

The yellow and green GND wire or GND screw of the speed dome should be reliably connected by several strands of copper wire with no less than 25mm<sup>2</sup> and indoor equipotential GND terminal. Please refer to Figure 4-2 for lightningproof installation mode.

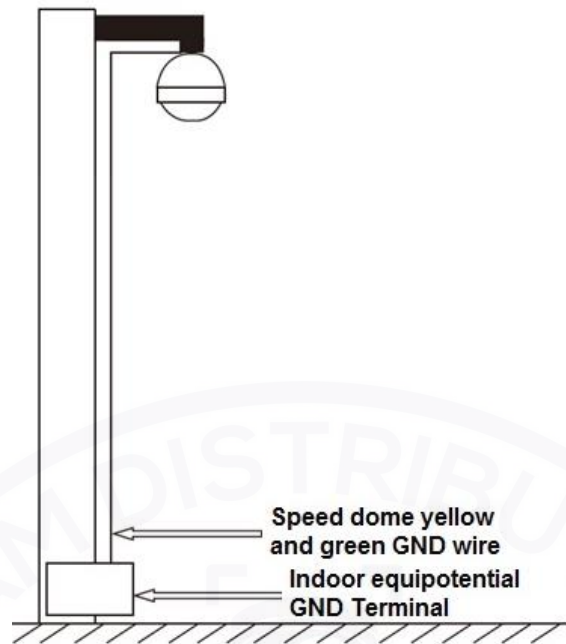
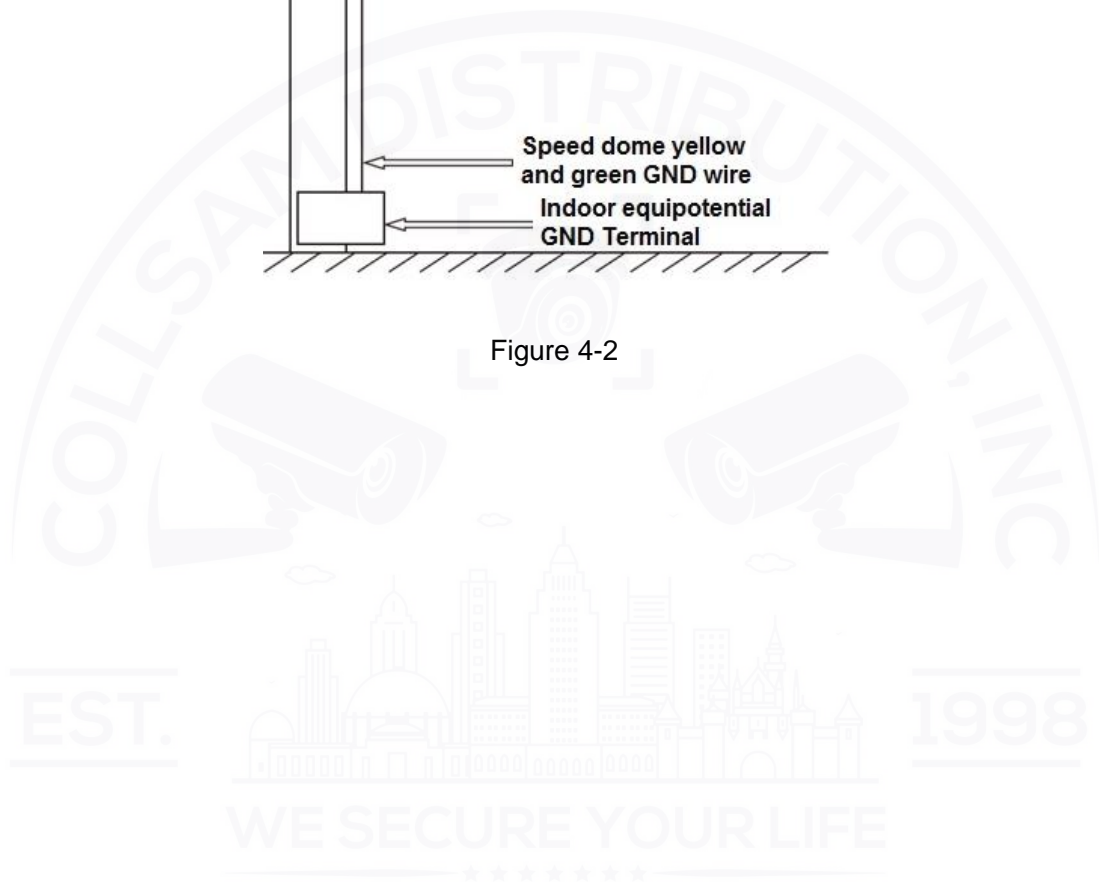

Figure 4-2



## 5 APPENDIX II ABOUT RS485 BUS

### 5.1 RS485 Bus Main Feature

RS485 is semi duplex communication cable of impedance  $120\ \Omega$  . Its max load amount is 32 effective loads (including main control device and devices to be charged).

### 5.2 RS485 Bus Transmission Distance

When we take 0.56mm (24AWG) twisted-pair as communication cable, the max transmission distance (theoretically) are listed below (according to different baud rates).

Baud Rate	Max Distance
2400 BPS	1800M
4800 BPS	1200M
9600 BPS	800M

In the following situations, the max transmission distance shall become shorter accordingly:

- The communication cable is a little bit thin;
- The surrounding environment has strong electromagnetic interference;
- There are too much devices connected to the RS485 bus;

And vice versa, the max transmission distance shall become longer.

### 5.3 The Problem in Practical Use

In practical usage, we usually adopt star type connection. The terminal resistance shall connect to the furthest two devices (Such as device 1# and device 15# in Figure 5-1 ). But this connection way does not conform to RS485 Bus standard. When the distances between devices are too long, the signal reflection occurs and anti-jamming decreases, thus the signal reliability becomes very low. You can see speed dome is not under control or speed dome is running automatically and cannot stop.

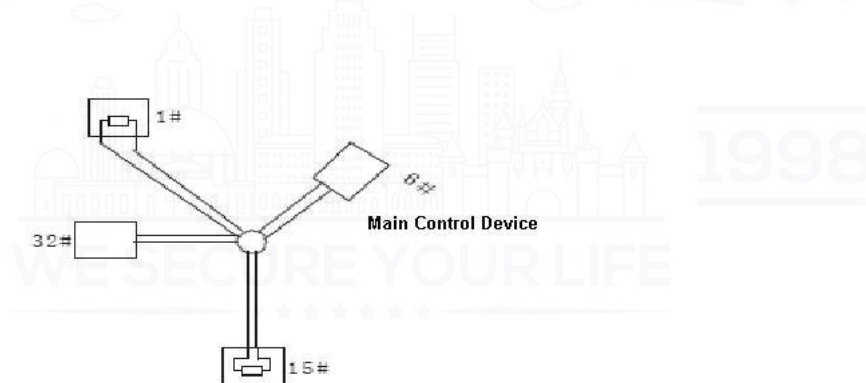

Figure 5-1

In this situation, we recommend RS485 distributor. This device can turn star type connection into the connection that conforms to RS485 bus industry standard, which can avoid the above mentioned problems and enhance communication reliability. See Figure 5-2.

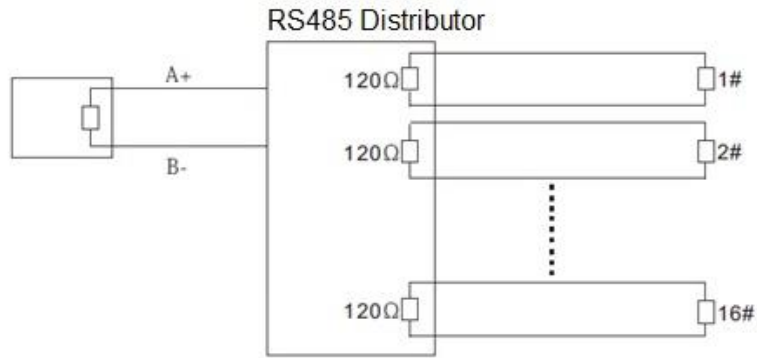

Figure 5-2

## 5.4 RS485 Bus FAQ

Phenomenon	Possible Reasons	Solution
Speed dome can run self-diagnosis but I cannot control it.	<ul style="list-style-type: none"> <li>● Host address(baud rate) and speed dome address(baud rate) are not match;</li> <li>● Positive and negative end of RS485 Bus are misconnected;</li> <li>● Connection cable is loose;</li> <li>● RS485 Bus connection are cut off;</li> </ul>	<ul style="list-style-type: none"> <li>● Modify host or speed dome setup ;</li> <li>● Switch RS485 positive end and negative end;</li> <li>● Fix connection cable firmly;</li> <li>● Replace RS485 Bus.</li> </ul>
I can control the speed dome but is not smooth	<ul style="list-style-type: none"> <li>● RS485 Bus connection are not good;</li> <li>● One RS485 bus is off;</li> <li>● The distance between host and speed dome is too far;</li> <li>● Parallel connected too much speed domes.</li> </ul>	<ul style="list-style-type: none"> <li>● Connect RS 485 Bus again;</li> <li>● Replace RS485 Bus;</li> <li>● Add terminal matching resistance;</li> <li>● Add RS485 distributor.</li> </ul>

EST.



1998

## 6 APPENDIX III THE 24V AC WIRE GAUGE AND

### TRANSMISSION DISTANCE RELATIONSHIP SHEET

It is the recommended transmission distance when the cable diameter is fixed and the 24V AC power consumption is below 10%. For the AC device, the max permission voltage power consumption is 10%. For example, when a device of rated power 20W installed from the transformer 141 inches (42m), then the min cable diameter is 0.8000mm.

mm Feet (m)	0.8000	1.000	1.250	2.000
w				
5	488.52 (148.90)	763.31 (232.66)	1192.67 (363.53)	3053.25 (930.63)
10	244.26 (74.45)	381.66 (116.33)	596.34 (181.76)	1526.62 (465.31)
15	162.84 (49.63)	254.44 (77.55)	397.56 (121.18)	1017.75 (310.21)
20	122.13 (37.23)	190.83 (58.16)	298.17 (90.88)	763.31 (232.66)
25	97.70 (29.78)	152.66 (46.53)	238.53 (72.71)	610.65 (186.13)
30	81.42 (24.82)	127.22 (38.78)	198.78 (60.59)	508.87 (155.10)
35	69.79 (21.27)	109.04 (33.24)	170.38 (51.93)	436.18 (132.95)
40	61.06 (18.61)	95.41 (29.08)	149.08 (45.44)	381.66 (116.33)
45	54.28 (16.54)	84.81 (25.85)	132.52 (40.39)	339.25 (103.40)
50	48.85 (14.89)	76.33 (23.27)	119.27 (36.35)	305.32 (93.06)
55	44.41 (13.54)	69.39 (21.15)	108.42 (33.05)	277.57 (84.60)
60	40.71 (12.41)	63.61 (19.39)	99.39 (30.29)	254.44 (77.55)
65	37.58 (11.45)	58.72 (17.90)	91.74 (27.96)	234.87 (71.59)
70	34.89 (10.64)	54.52 (16.62)	85.19 (25.97)	218.09 (66.47)
75	32.57 (9.93)	50.89 (15.51)	79.51 (24.24)	203.55 (62.04)
80	30.53 (9.31)	47.71 (14.54)	74.54 (22.72)	190.83 (58.16)
85	28.74 (8.76)	44.90 (13.69)	70.16 (21.38)	179.60 (54.74)
90	27.14 (8.27)	42.41 (12.93)	66.26 (20.20)	169.62 (51.70)
95	25.71 (7.84)	40.17 (12.25)	62.77 (19.13)	160.70 (48.98)
100	24.43 (7.45)	38.17 (11.63)	59.63 (18.18)	152.66 (46.53)

## 7 APPENDIX IV 12V DC WIRE GAUGE AND

### TRANSMISSION DISTANCE RELATIONSHIP SHEET

The recommended max transmission distance is under the following environments: The wire diameter is fixed and the DC 12V power voltage loss rate is below 10%. For the device of DC power supplying, the max allowed voltage loss rate is 10%. All the wires listed in the following sheet are copper wire. (Copper wire resistance  $\rho = 0.0175\Omega * \text{mm}^2/\text{m}$ )

mm Feet (m) w	0.8000	1.000	1.250	2.000
5	122.13 (37.23)	190.83 (58.16)	298.17 (90.88)	763.31 (232.66)
10	61.06 (18.61)	95.41 (29.08)	149.08 (45.44)	381.66 (116.33)
15	40.71 (12.41)	63.61 (19.39)	99.39 (30.29)	254.44 (77.55)
20	30.53 (9.31)	47.71 (14.54)	74.54 (22.72)	190.83 (58.16)
25	24.43 (7.45)	38.17 (11.63)	59.63 (18.18)	152.66 (46.53)
30	20.35 (6.20)	31.80 (9.69)	49.69 (15.15)	127.22 (38.78)
35	17.45 (5.32)	27.26 (8.31)	42.60 (12.98)	109.04 (33.24)
40	15.27 (4.65)	23.85 (7.27)	37.27 (11.36)	95.41 (29.08)
45	13.57 (4.14)	21.20 (6.46)	33.13 (10.10)	84.81 (28.85)
50	12.21 (3.72)	19.08 (5.82)	29.82 (9.09)	76.33 (23.27)
55	11.10 (3.38)	17.35 (5.29)	27.11 (8.26)	69.39 (21.15)
60	10.18 (3.10)	15.90 (4.85)	24.85 (7.57)	63.61 (19.39)
65	9.39 (2.86)	14.68 (4.47)	22.94 (6.99)	58.72 (17.90)
70	8.72 (2.66)	13.63 (4.15)	21.30 (6.49)	54.52 (16.62)
75	8.14 (2.48)	12.72 (3.88)	19.88 (6.06)	50.89 (15.51)
80	7.63 (2.33)	11.93 (3.64)	18.64 (5.68)	47.71 (14.54)
85	7.18 (2.19)	11.23 (3.42)	17.54 (5.35)	44.90 (13.69)
90	6.78 (2.07)	10.60 (3.23)	16.56 (5.05)	42.41 (12.93)
95	6.43 (1.96)	10.04 (3.06)	15.69 (4.78)	40.17 (12.25)
100	6.11 (1.86)	9.54 (2.91)	14.91 (4.54)	38.17 (11.63)

WE SECURE YOUR LIFE

## 8 APPENDIX V WIRE GAUGE REFERENCE SHEET

Metric bare wire diameter (mm)	AWG	SWG	Bare wire cross section (mm <sup>2</sup> )
0.050	43	47	0.00196
0.060	42	46	0.00283
0.070	41	45	0.00385
0.080	40	44	0.00503
0.090	39	43	0.00636
0.100	38	42	0.00785
0.110	37	41	0.00950
0.130	36	39	0.01327
0.140	35	/	0.01539
0.160	34	37	0.02011
0.180	33	/	0.02545
0.200	32	35	0.03142
0.230	31	/	0.04115
0.250	30	33	0.04909
0.290	29	31	0.06605
0.330	28	30	0.08553
0.350	27	29	0.09621
0.400	26	28	0.1257
0.450	25	/	0.1602
0.560	24	24	0.2463
0.600	23	23	0.2827
0.710	22	22	0.3958
0.750	21	/	0.4417
0.800	20	21	0.5027
0.900	19	20	0.6362
1.000	18	19	0.7854
1.250	16	18	1.2266
1.500	15	/	1.7663
2.000	12	14	3.1420
2.500	/	/	4.9080
3.000	/	/	7.0683

### Note

- This manual is for reference only. Slight difference may be found in the user interface.
- All the designs and software here are subject to change without prior written notice.
- All trademarks and registered trademarks are the properties of their respective owners.
- If there is any uncertainty or controversy, please refer to the final explanation of us.
- Please visit our website or contact your local service engineer for more information.