

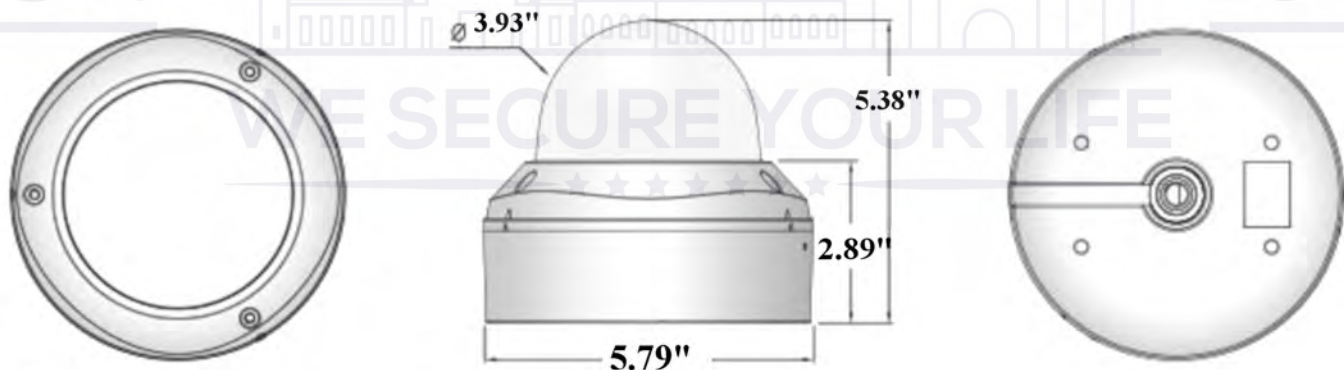

FEATURES

- 1080p FULL HD Flawless Video
- 1/2.9" Sony CMOS
- 2.8 ~ 12 mm Auto-Iris Varifocal Lens
- 0 Lux at IR On (COB IR : 4pcs)
- Upgraded Waterproof Housing (IP68 Rating)
- Smart IR. DNR (Digital Noise Reduction)
- True Day and Night (ICR)
- RS-485 Option
- Easy Installation
- DC 12V

DIMENSIONS



unit : Inch

SPECIFICATIONS

Resolution	1080p, 720p
Sensor	1/2.9 inch SONY CMOS (IMX-222 / IM x 322)
Total Pixels	2000(H) x 1241(V) = 2,482,000
Effective Pixels	1944(H) x 1092(V) = 2,122,648
Scanning System	Progressive
S/N (Y Signal)	More then 52 dB (AGC Off)
Video Output	SMPTE274M (HD-SDI) / CVBS: 1.0Vp-p (75ohm)
Min. Illumination	IR Product: 0 Lux at IR On
White Balance	Auto / Auto Ext / Preset / Manual
Shutter	Auto / Manual (1/30sec ~ 1/30,000sec)/ FLICKER
Brightness	Adjustable (0 ~ 20 Step)
Sens Up	OFF / x 2 ~ x 32
DNR	OFF / Low / Middle / High
Backlight	OFF / WDR / BLC / HLM
ACE	OFF / Low / Middle / High
Day & Night	Auto (Day <--> Night Time Change), Color, B/W, Extern
Privacy	OFF / ON
Motion	OFF / ON
Flip	OFF / ON
Defog	OFF / ON
Language	English, Chinese, Chinese(S), Japanese, Korean
Sharpness	Adjustable (0 ~ 10 Step)
Defog	OFF / SET
Communication Port	RS-485 (Pelco-D)
Smart IR	Adjustable (0 ~ 20 Step)
Operating Temp / Humidity	-10°C ~ +50°C(14°F ~ 122°F) / 30% ~ 80% RH
Storage Temp / Humidity	-20°C ~ +60°C(-4°F ~ 140°F) / 20% ~ 90% RH
Power	DC 12V
Signal Transmission	The distant difference is occurred according to cable option and other circumstances. (based on 5C-HFBT : HD-SDI (200M) / EX-SDI (500M))