

FEATURES

- 1/3 INCH SONY CMOS
- HD-SDI (1080P, 720P) / High Resolution (1000 TV Line OVER)
- HD-SDI (High Definition Serial Digital Interface) / 0 Lux at IR On (IR LED 40pcs)
- Upgraded Waterproof Housing (IP68 rating) / MDIR (Motion Detection IR)
- WDR (Wide Dynamic Range) / DNR (Digital Noise Reduction) / Smart IR
- True Day & Night(ICR) / Easy Installation : 3Axis Concealed Bracket
- DC Auto IRIS & TDN V/F Lens 2.8-12mm

SPECIFICATION

Resolution	HD-SDI(1080P, 720P) / 1000 TV LINE OVER
Sensor	1/3 INCH SONY CMOS
Total Pixels	2010(H) X 1108(V) = 2,227,080
Effective Pixels	1944(H) X 1092(V) = 2,122,648
Scanning System	PROGRESSIVE
S/N (Y signal)	More than 52 dB (AGC Off)
Video Output	SMPT292M (HD-SDI) / (CVBS: 1.0Vp-p (75ohm) : Option)
Min.Illumination	0 Lux at IR On
White Balance	AUTO / AUTO EXT / PUSHING / MANUAL
Electronic shutter speed	AUTO / MANUAL (1/30sec ~ 1/60,000sec)
Brightness	ADJUSTABLE (0 - 20 STEP)
SENS_UP	OFF / X2 / X3 / X4
DNR	OFF / LOW / MIDDLE / HIGH
WDR/BLC	OFF / WDR / BLC
HLM	OFF / SET
ACE	OFF / ON
Day & Night	AUTO (Day <-> Night TIME Change), COLOR, B/W, EXTERN, MDIR
Smart IR	OFF / ON
Privacy	OFF / ON (31 Zone)
Motion Detection	OFF / ON
D.ZOOM	0 - X127
FLIP	OFF / ON
FREEZE	OFF / ON
Language	ENGLISH
Sharpness	ADJUSTABLE (0 - 10 STEP)
Image Conversion	OFF / ON
Operating Temperature/Humidity	-10°C~+50°C / 30%~80% RH
Storage Temperature/Humidity	-20°C~+60°C / 20%~90% RH
Power	DC12V ±10% Only / DC12V-AC24V ±10% DualPower (option)
signal Transmission	100 - 150m (Max transmission range is depends on the cable manufacturer and the installation environment.)

► Above specifications may be changed without any notice.

Installation

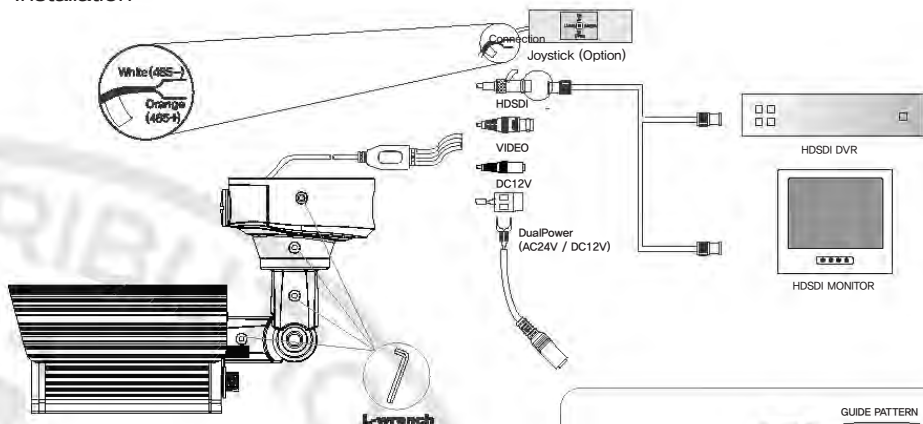

External Focus control

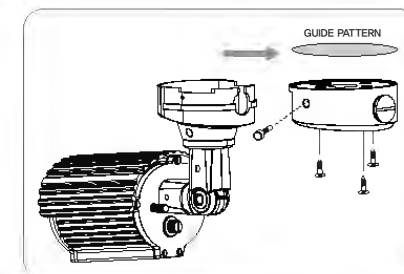
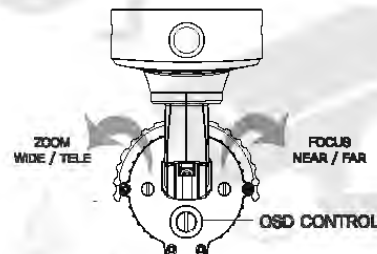

Pan & Tilt control

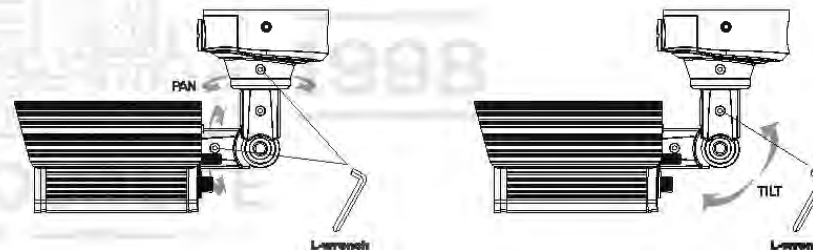

Distributed By
 Collsam Distributions; Inc.
 Sales: (951) 282-8707 sales@Collsam.com
 Support: (213) 210-5744 support@Collsam.com
 Website: www.Collsam.com

