

2 MP Night Color Dome Network Camera

H.265 True WDR Dome Network Camera



- 1/2.8-in. 2 MP Progressive-scan STARVIS™ CMOS Sensor
- Smart H.265+ and Smart H.264+ Dual Codec
- Triple-stream encoding
- 1080p (1920 x 1080) at 30 fps Maximum Resolution
- 3.6 mm Fixed Lens
- Smart Detection Supported
- True Wide Dynamic Range (120 dB)
- Intelligent Video System
- IP67 Ingress Protection and IK10 Vandal Resistance
- Enhanced Power and Data Transmission Distances (ePoE)
- Five-year Warranty*



System Overview

The Dahua camera with Night Color Technology offers 24-hour color surveillance in applications with at least 1 lux of ambient light. The Night Color Technology camera utilizes back-illuminated pixel technology, a large aperture lens, and a STARVIS™ sensor to deliver color details without the need for external IR or white-light illumination. This camera is ideal for monitoring casino floors, parking lots, building exteriors and interiors, educational facilities, and urban streets. The IP67 and the IK10 ratings ensure continuous operation in the harshest environments.

Functions

Night Color Technology

The DH-IPC-HDBW4239RN-ASE Night Color Camera incorporates a high-performance STARVIS™ sensor and a large aperture lens to produce crisp, clear color images in low light environments. This light-sensitive technology allows the camera to capture more available light and reproduce color images with superior detail and contrast. Dahua Night Color Technology cameras are ideal for applications with at least 1 lux of ambient or artificial light, including parking lots, schools, urban streets and museums.

True Wide Dynamic Range

The camera achieves vivid images, even in the most intense contrast lighting conditions, using industry-leading wide dynamic range (WDR) technology. For applications with both bright and low lighting conditions that change quickly, True WDR (120 dB) optimizes both the bright and dark areas of a scene at the same time to provide usable video.

Intelligent Video System (IVS)

IVS is a built-in video analytic algorithm that delivers intelligent functions to monitor a scene for Tripwire violations, intrusion detection, and abandoned or missing objects. A camera with IVS quickly and accurately responds to monitoring events in a specific area. In addition to scene analytics, offers tamper detection by recognizing a dramatic scene change and generating a warning message to inspect the camera.

Enhanced Power over Ethernet (ePoE) Technology

Dahua's innovative ePoE technology offers a plug-and-play solution to transmit power and data over long distances via Ethernet or coaxial cables, reducing installation time and saving money. ePoE technology is a viable, cost-effective solution for extending transmission distances and for converting existing, coax-based analog systems into IP systems. For video security and surveillance installers, ePoE technology saves time and money by reducing overall cabling requirements, allowing for existing coax cable to be used, and minimizing the number of peripheral devices needed. For new installations, ePoE offers the ability to design long-distance applications without the need for additional repeaters.

Smart H.265

Smart H.265+ is the optimized implementation of the H.265 codec that uses a scene-adaptive encoding strategy, dynamic GOP, dynamic ROI, flexible multi-frame reference structure and intelligent noise reduction to deliver high-quality video without straining the network. Smart H.265+ technology reduces bit rate and storage requirements by up to 70% when compared to standard H.265 video compression.

Cybersecurity

Dahua network cameras are equipped with a series of key cybersecurity technologies including: security authentication and authorization, access control, trusted protection, encrypted transmission, and encrypted storage. These technologies improve the camera's ability to prevent malicious access and to protect data.

Protection

The camera allows for ±30% input voltage tolerance, suitable for the most unstable conditions for outdoor applications. Its 6KV lightning rating provides effective protection for both the camera and its structure against lightning. Subjected and certified to rigorous dust and immersion tests (IP67) and impact tests (IK10), the camera is the choice for installation in even the most unforgiving environments.

*Warranty applies to products sold through an authorized Dahua Dealer.

Technical Specification					
Camera					
Image Sensor	1/2.8-in. 2 MP Progressive-scan STARVIS™ CMOS				
Effective Pixels	1920(H) x 1080(V)				
RAM/ROM	256 MB/32 MB				
Scanning System	Progressive				
Electronic Shutter Speed	Auto, Manual; 1/3 s to 1/100000 s				
Minimum Illumination	Color: 0.001 lux at F1.0 (1/3 s, 30 IRE) Color: 0.006 lux at F1.0 (1/30 s, 30 IRE)				
S/N Ratio	More than 50 dB				
Lens					
Lens Type	Fixed				
Mount Type	Board-in				
Focal Length	3.6 mm				
Maximum Aperture	F1.0				
Angle of View	Horizontal: 87° Vertical: 47°				
Focus Control	Fixed				
Close Focus Distance	1.60 m (5.30 ft)				
DORI ¹ Distance	Lens	Detect (8 ppf)	Observe (19 ppf)	Recognize (38 ppf)	Identify (76 ppf)
	3.6 mm	53 m (174 ft)	21 m (69 ft)	11 m (36 ft)	5 m (16 ft)
Installation Angle					
Range	Pan: 0° to 360° Tilt: 0° to 80° Rotation: 0° to 360°				
Video					
Compression	H.265, H.264, H.264B, H.264H, MJPEG (Sub Stream)				
Smart Codec	Smart H.265+, Smart H.264+				
Streaming Capability	Three (3) Streams				
Resolution	1080p (1920 x 1080), 1.3 MP (1280 x 960), 720p (1280 x 720), D1 (704 x 480), VGA (640 x 480), CIF (352 x 240)				
Frame Rate	Main Stream: 1080 at 30 fps				
	Sub Stream 1: D1 at 30 fps				
	Sub Stream 2: 1080p at 30 fps				
Bit Rate Control	CBR/VBR				
Bit Rate	H.264: 24 K to 10240 Kbps H.265: 14 K to 9984 Kbps				
Day/Night	Color (default), Auto (Electronic), B/W				
BLC Mode	BLC, HLC, True WDR (120 dB)				
White Balance	Auto, Natural, Street Lamp, Outdoor, Manual				
Gain Control	Auto, Manual				
Noise Reduction	3D DNR				
Motion Detection	Off, On (4 Zones, Rectangular)				
Region of Interest	Off, On (4 Zones)				
Digital Zoom	16x				
Flip	0°, 90°, 180°, 270°				
Mirror	Off, On				
Privacy Masking	Off, On (4 Areas, Rectangular)				
Audio					
Compression	G.711a, G.711Mu, G.726				
Network					
Ethernet	RJ-45 (10/100 Base-T)				
Protocol	HTTP, HTTPS, TCP, ARP, RTSP, RTP, RTCP, UDP, PPPOE, IEEE802.1X, SMTP, SNMP, FTP, DHCP, DNS, DDNS, PPPoE, IPV4/V6, QoS, UPnP, NTP, Bonjour, IEEE 802.1, Multicast, ICMP, IGMP, TLS, SSH, NFS				
Interoperability	ONVIF Profile S&G, API				
Streaming Method	Unicast, Multicast				
Maximum User Access	10 Users /20 Users				
Edge Storage	Network Attached Storage (NAS) Local PC for Instant Recording Micro SD Card Slot, 128 GB maximum				
Web Viewer	IE, Chrome, Firefox, Safari				
Management Software	Smart PSS, DSS, DMSS				
Mobile Operating System	IOS, Android				
Cybersecurity	Video Encryption, Firmware Encryption, Configuration Encryption, Digest, WSSE, Account Lockout, Security Logs, IP/MAC Filtering, Generating and Importing X.509 Certification, Syslog, HTTPS, 802.1x, Trusted Boot, Trusted Execution, Trusted Upgrade				
Certifications					
Safety	UL 60950-1 EN 60950:2000				
Electromagnetic Compatibility (EMC)	FCC CFR 47 Part 15 Subpart B				
Interface					
Audio	Input: One (1) Channel Output: One (1) Channel				
Alarm	Input: One (1) Channel (5 mA, 5 VDC) Output: One (1) Channel (300 mA, 12 VDC)				
Electrical					
Power Supply	12 VDC, 1 A (±30%); PoE (802.3af, Class 0)				
Power Consumption	< 3.7 W				

1. The DORI distance is a measure of the general proximity for a specific classification to help pinpoint the right camera for your needs. The DORI distance is calculated based on sensor specifications and lab test results according to EN 62676-4, the standard that defines the criteria for the Detect, Observe, Recognize and Identify classifications.

Environmental

Operating Temperature	-30° C to +60° C (-22° F to +140° F) Less than 95% RH
Storage Temperature	-30° C to +60° C (-22° F to +140° F) Less than 95% RH
Ingress Protection	IP67
Vandal Resistance	IK10

Construction

Casing	Metal
Dimensions	ø122.0 mm x 88.90 mm (ø4.80 in. x 3.50 in.)
Net Weight	0.44 kg (0.97 lb)
Gross Weight	0.58 kg (1.29 lb)

Intelligence

IVS triggers an alarm and takes a defined action for the following events:

Standard Features	<ul style="list-style-type: none"> Tampering with the camera. Error writing to an onboard Micro SD card. Error sending or receiving data over the network. Unauthorized access to the camera.
Premium Features	
Motion	An object moves through any part of the scene.
Tripwire	A target crosses a user-defined line.
Intrusion	A target enters or exits a defined perimeter.
Scene Change	A person or object moves the camera to change the scene or covers the camera to obscure the scene.
Abandoned/Missing Object	A target leaves an object in designated area, or a target removes an object from the same designated area.

ePoE Transmission Distances

Via CAT5E/CAT6 Ethernet Cable

ePoE supply voltage 48 V
Maximum DC resistance < 10 Ω/100 m

Cable Length, m (ft)	Bandwidth, Mbps	PoE Load Capacity, W	Hi-PoE Load Capacity, W	Working Mode
100 (328)	100	25.5	53	IEEE/E100
200 (656)	100	25.5	33	E100
300 (984)	100	19	19	E100
400 (1312)	10	17	17	E10
500 (1640)	10	13	13	E10
800 (2625)	10	7	7	E10

Via CAT5E/CAT6 Ethernet Cable

ePoE supply voltage 53 V
Maximum DC resistance < 10 Ω/100 m

Cable Length, m (ft)	Bandwidth, Mbps	PoE Load Capacity, W	Hi-PoE Load Capacity, W	Working Mode
100 (328)	100	25.5	53	IEEE/E100
200 (656)	100	25.5	47	E100
300 (984)	100	25.5	32	E100
400 (1312)	10	23	26	E10
500 (1640)	10	20	20	E10
800 (2625)	10	13	13	E10

Via RG-59 Coaxial Cable

ePoE supply voltage 48 V
Maximum DC resistance < 5 Ω/100 m

Cable Length, m (ft)	Bandwidth, Mbps	PoE Load Capacity, W	Hi-PoE Load Capacity, W	Working Mode
100 (328)	100	25.5	50	IEEE/E100
200 (656)	100	25.5	30	E100
300 (984)	100	18	18	E100
400 (1312)	100	15	15	E100
500 (1640)	10	12	12	E10
800 (2625)	10	6	6	E10
1000 (3281)	10	5	5	E10

Via RG-59 Coaxial Cable

ePoE supply voltage 53 V
Maximum DC resistance < 5 Ω/100 m

Cable Length, m (ft)	Bandwidth, Mbps	PoE Load Capacity, W	Hi-PoE Load Capacity, W	Working Mode
100 (328)	100	25.5	52	IEEE/E100
200 (656)	100	25.5	48	E100
300 (984)	100	25.5	30	E100
400 (1312)	100	20	23	E100
500 (1640)	10	16	16	E10
800 (2625)	10	10	10	E10
1000 (3281)	10	8	8	E10

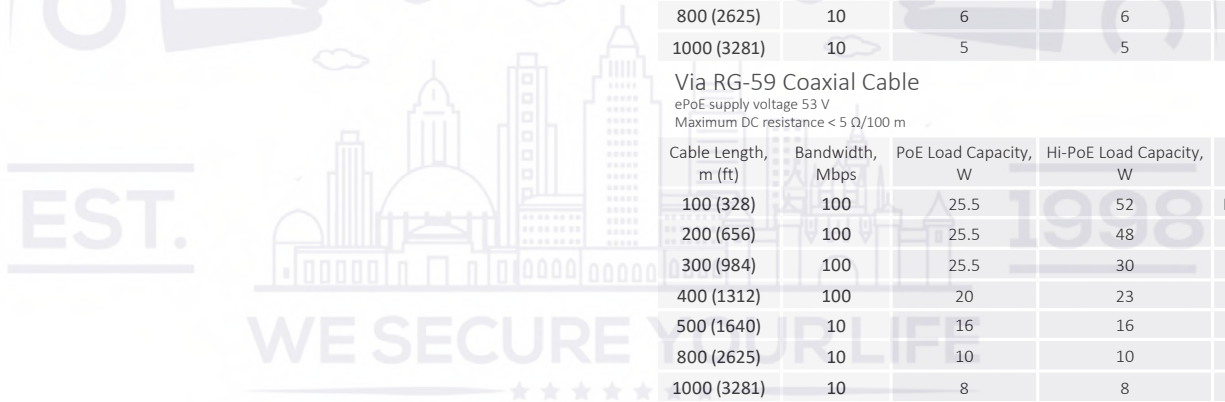

Ordering Information		
Type	Part Number	Description
2 MP Camera	DH-IPC-HDBW4239RN-ASE	2 MP Night Color Dome Network Camera, 3.6 mm, WDR, IVS
Accessories, optional	PFA106	Mount Adapter (For use with PFB305W and PFB220C)
	PFA137	Junction Box
	PFA151	Corner Mount Bracket (For use with PFB305W wall mount)
	PFA152-E	Pole Mount
	PFB200C	In-ceiling Mount
	PFB203W	Wall Mount
	PFB220C	Ceiling Mount (For use with PFA106 mount adapter)
	PFB305W	Wall Mount (For use with PFA106 mount adapter)
	DH-PFM321D-US	12 VDC, 1 A Power Adapter
ePoE Accessories, optional	LR1002	EoC Passive Converter
	LR1002-1EC	Single-port EoC Receiver

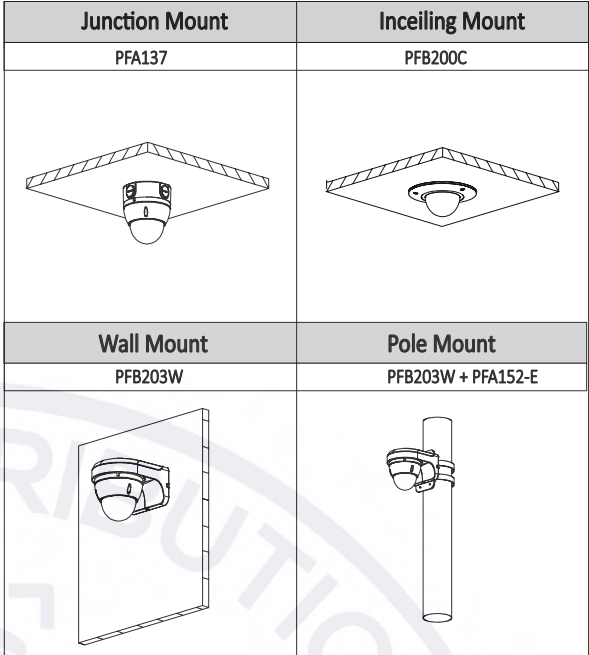

Dimensions (mm/inch)

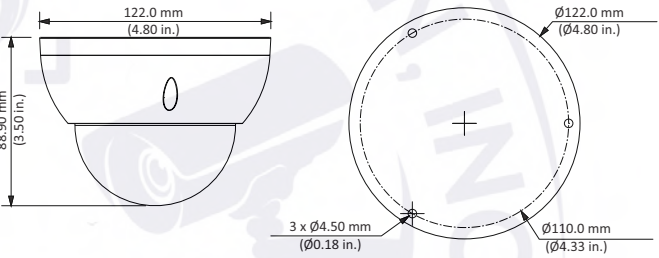

Accessories

Optional:



ePoE Applications

Pure Ethernet



Passive EoC



EoC with Single-port EoC Receiver

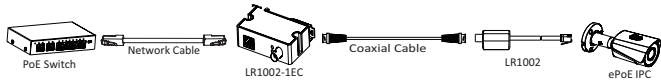

Rev 001.010 © 2021 Dahua Technology USA. All rights reserved. Design and specifications are subject to change without notice.

