

Quick Guide

Roughneck V2000D-PTZ

Outdoor IR PTZ Dome Camera Series



NDA Compliant



Cybersecurity Notification: All network connected devices should use best practices for accessing the device. To that end, these network cameras do not have a default password. A user defined password with minimum password strength requirements must be set to access the device. See page 14 of this Quick Guide for set-up instructions.



Table of Content

1	Product Overview	4
1.1	Introduction	4
1.2	Physical Characteristics	4
2	Installation and Mounting	8
2.1	Package Contents	8
2.2	Installation	8
2.2.1	Checking Appearance	8
2.2.2	Inserting or Removing the SD Card	9
2.2.3	Installing the Camera with Wall Mount	9
2.2.4	Connecting the Cables	11
3	Connection	13
3.1	Network Topology	13
3.2	System Requirements	13
3.3	Connecting Process	14
3.3.1	Default IP address	14
3.3.2	Connecting from a Computer & Viewing Preparation	14
3.4	IP Toolbox	18
▪	Appendix	21



EST.

1998



WARNING

- This camera operates at 24 VAC/ 48 VDC / PoE (IEEE 802.3bt Class 6).
- Installation and service should be performed only by qualified and experienced technicians and comply with all local codes and rules to maintain your warranty.
- We are NOT liable of any damage arising either directly or indirectly from inappropriate installation which is not depicted within this documentation.
- To reduce the risk of fire or electric shock, do not expose the product to rain or moisture.
- Wipe the camera with a dry soft cloth. For tough stains, slightly apply with diluted neutral detergent and wipe with a dry soft cloth.
- Do not apply benzene or thinner to the camera, which may cause the surface to be melted or lens fogged.
- Avoid aligning the lens with extremely bright objects (e.g., light fixtures) for long periods of time.
- Although this camera is waterproof and suitable for both indoor and outdoor usages, please do not sink the camera into water. Contact your dealer in case of sunk.
- Avoid operating or storing the camera in the following locations:
 - Extremely humid, dusty, or hot/cold environments (recommended operating temperature: -40°F to +140°F/--40°C to +60°C)
 - Close to sources of powerful radio or TV transmitters
 - Close to fluorescent lamps or objects with reflections
 - Under unstable or flickering light sources

	CAUTION RISK OF ELECTRIC SHOCK DO NOT OPEN		THIS SYMBOL INDICATES THAT DANGEROUS VOLTAGE CONSTITUTING A RISK OF ELECTRIC SHOCK IS PRESENT WITHIN THE UNIT.
CAUTION: TO REDUCE THE RISK OF ELECTRIC SHOCK, DO NOT REMOVE THE COVER. NO USER-SERVICEABLE PARTS INSIDE. REFER SERVICING TO QUALIFIED SERVICE PERSONNEL.			THIS SYMBOL INDICATES THAT IMPORTANT OPERATING AND MAINTENANCE INSTRUCTIONS ACCOMPANY THIS UNIT.



WEEE (Waste Electrical and Electronic Equipment). Correct disposal of this product (applicable in the European Union and other European countries with separate collection systems). This product should be disposed of, at the end of its useful life, as per applicable local laws, regulations, and procedures.

Get Started

This quick guide is designed as a reference for installation of the camera. For additional information on the camera's features, functions, and detailed explanation of the web interface controls, refer to User's Manual for details. Please read this quick guide thoroughly and save it for future use before attempting to install the camera. From this guide you will get:

- Product Overview: The physical parts, features and dimensions of the camera.
- Installation and Connection: The instructions on installation and wires connection for the camera.

FCC Compliance Statement



Information to the user: This unit has been tested and found to comply with the limits for a Class B digital device pursuant to Part 15 of the FCC Rules. Operation is subject to the following two conditions: (1) this device may not cause harmful interference, and (2) this device must accept any interference received, including interference that may cause undesired operation. These limits are designed to provide reasonable protection against harmful interference in a residential installation. This unit generates, uses, and can radiate radio frequency energy and, if not installed and used in accordance with the manual, may cause harmful interference to radio communications. However, there is no guarantee that interference will not occur in a particular installation.

If this unit does cause harmful interference to radio or television reception, which can be determined by turning the unit off and on, the user is encouraged to try to correct the interference by one or more of the following measures:

- Reorient or relocate the receiving antenna.
- Increase the separation between the unit and receiver.
- Connect the unit to an outlet on a circuit different from that to which the receiver is connected.
- Consult the dealer or an experienced radio/TV technician for help.

Caution Changes or modifications not expressly approved by the party responsible for compliance could void the user's authority to operate the unit.

CE Statement



Operation is subject to the following two conditions: (1) this device may not cause harmful interference, and (2) this device must accept any interference received, including interference that may cause undesired operation. The manufacturer declares that the unit supplied with this guide is compliant with the essential protection requirements of EMC directive and General Product Safety Directive GPSD conforming to requirements of standards EN55022 for emission, EN 50130-4 for immunity, EN 300 and EN 328 for WIFI.

The camera is IP66 and IK7 rated. It also meets regulations required to be NDAA, GSA schedule and TAA approved.

1 Product Overview

1.1 Introduction

The information in this quick guide is for the V2000D-PTZ Series of Outdoor IR Camera Domes. It includes the V2002D-PTZ 2 MP and the V2005D-PTZ 5 MP models.

1.2 Physical Characteristics

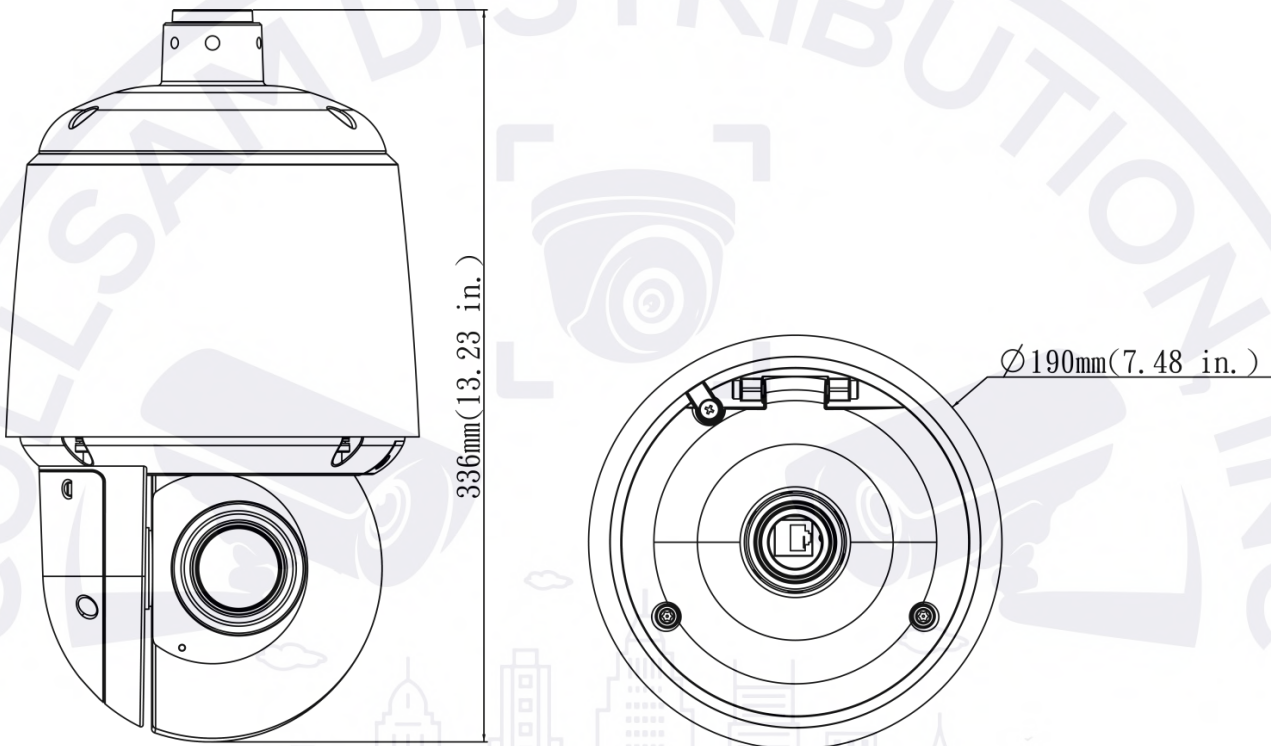

Figure 1 - 1: Physical Dimensions

Unit: mm (in.)

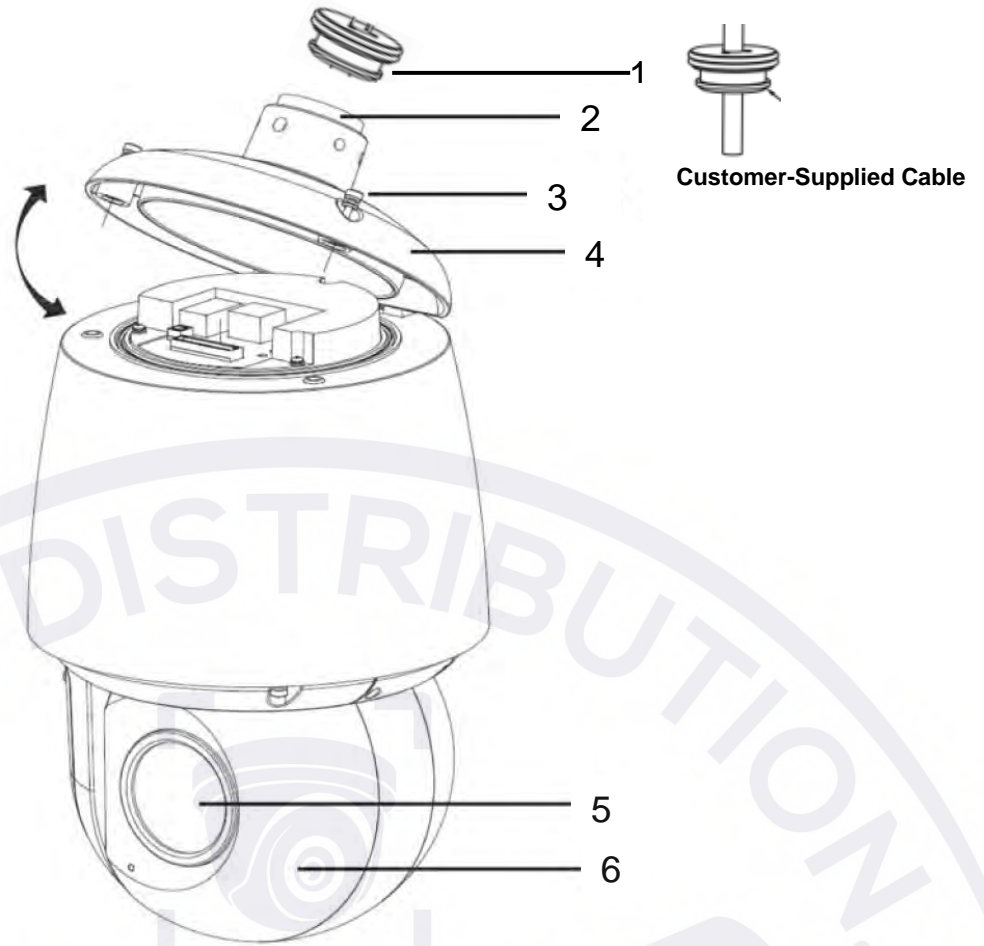

Figure 1 - 2: Parts Pictorial Index

No	Description
1	Sealing Ring
2	Camera 1-1/2" NPT pendant adapter
3	Screws (x2) to open and lock camera top cover
4	Camera top cover
5	Camera lens
6	Camera head

Table 1 - 1: Parts Pictorial Index Description

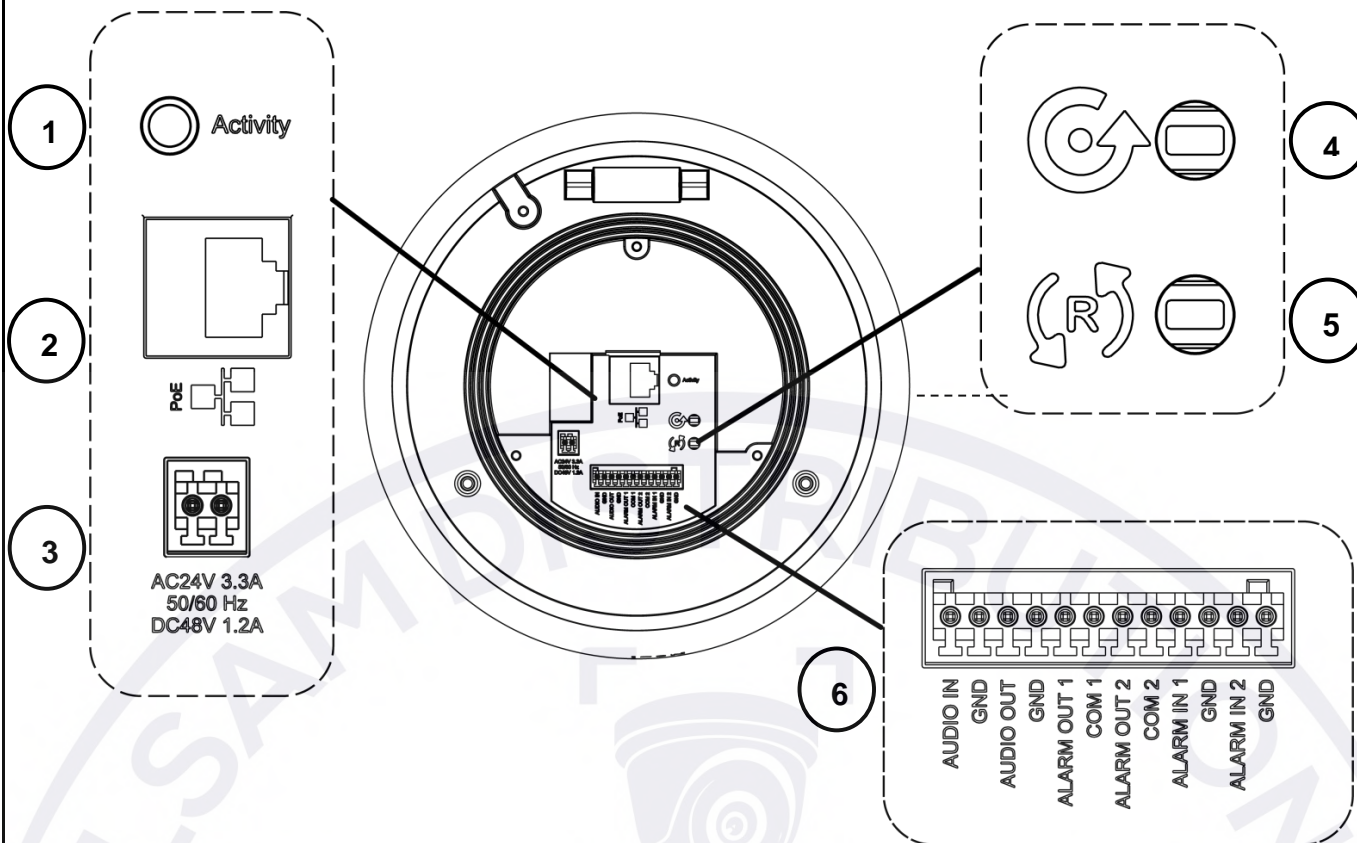
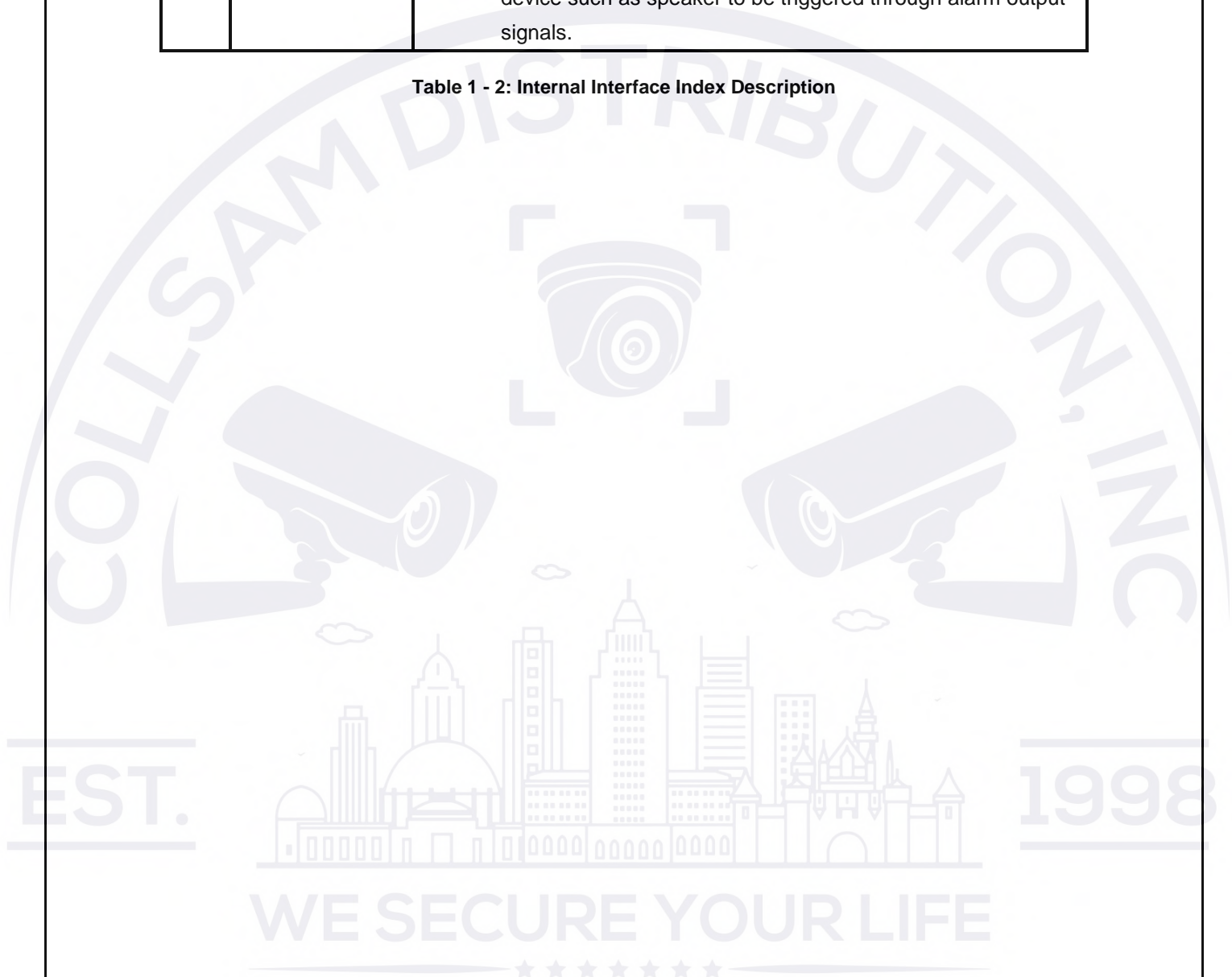

Figure 1 - 3: Internal Interface Pictorial Index

No.	Name	Description
1	Activity Behaviors	Booting: Fast flashing green LED indicates the camera is currently booting.
		Software updating: Alternating fast/slow flashing green LED indicates the camera is updating software.
		Booting failure: A slower flashing green LED indicates the camera failed to boot.
		Booting completion: When the green light is off, the LED indicates the camera has completed booting.
2	RJ-45 Network Port	Connect the RJ-45 connector to this port with a PoE (Class 6) compatible network device that supplies power through the Ethernet cable.
3	Power Terminal	The port is used to connect with external either 24 VAC or 48 VDC power supply.
4	Default Button	Default: Press the button for 5 seconds to restore the camera settings to factory default.
5	Reset Button	Reset: Press the button for approximately 1 second to reboot the camera.
6	DI/DO Port	DI/DO (Digital Input/Output) ports are equipped for external devices, e.g., smoke detector, siren, microphone.

		<ul style="list-style-type: none"> • Alarm In: Via “GND” and “Alarm In” ports, connect to external device that can trigger alarm input signals. • Alarm Out: Via “COM” and “Alarm Out” ports, connect to external device to be triggered through alarm output signals. • Audio In: Via “GND” and “Audio In” ports, connect to external device such as microphone that receives sound for camera. • Audio Out: Via “GND” and “Audio Out” ports, connect to device such as speaker to be triggered through alarm output signals.
--	--	--

Table 1 - 2: Internal Interface Index Description



2 Installation and Mounting

2.1 Package Contents

Check if all items listed below are included in the packing box.

- IR PTZ Camera Dome * 1
- Adapter Ring * 1
- T20 torx wrench * 1
- T6 torx wrench * 1
- T20 Stop Screw * 3
- 12-pin Terminal connector for I/O function * 1
- 2-pin Terminal block * 1
- Sealing Ring * 1 (pre-installed; required to maintain IP66 rating)
- Printed Quick Guide * 1

2.2 Installation

The following tools may be helpful to complete the installation:

- Drill
- Screwdrivers
- Wire cutters

2.2.1 Checking Appearance

When unpacking, check to see if there is any visible damage to the appearance of the camera and its accessories. The protective materials used for the packaging should protect the camera from most accidents during shipment. Remove the protective materials from the camera after every item is properly checked in accordance with the list in **Package Contents**.

2.2.2 Inserting or Removing the SD Card

1. Remove the two screws (1) located on the micro SD card cover. Carefully pull open the micro SD card cover and insert or remove the micro SD card into or from the camera.

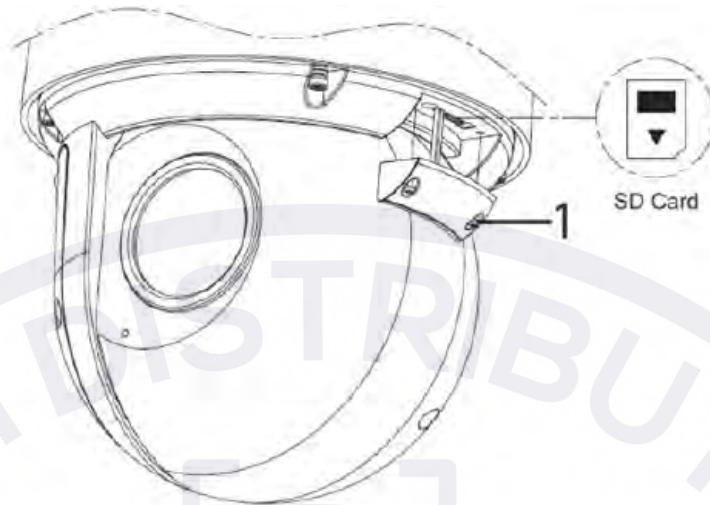

Figure 2 - 1: Inserting or Removing The Micro SD Card

2.2.3 Installing the Camera with Wall Mount

1. Based on your need, make sure that all cables have been passed through the wall mount and the pendant adapter. Use waterproof tape to wrap the thread of pendant adapter and then lock the pendant adapter on the wall mount.

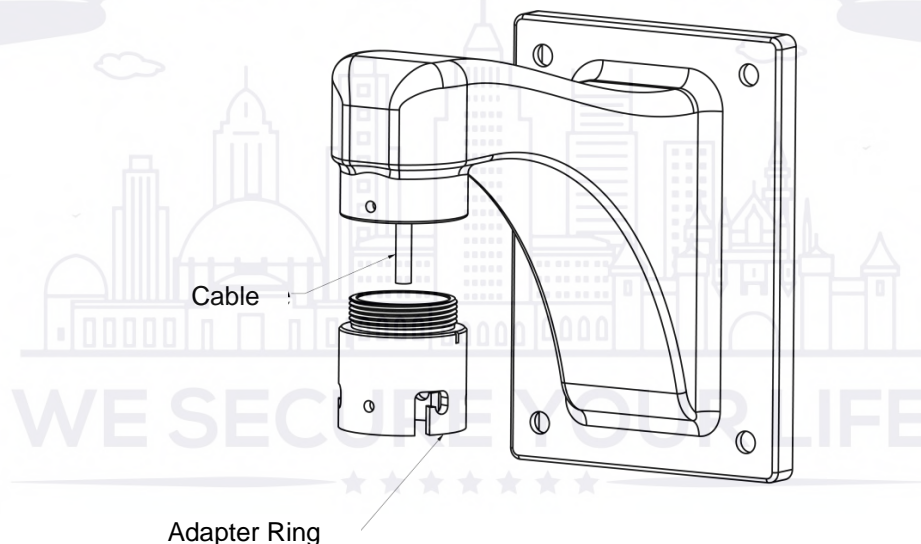

Figure 2 - 2: Locking the Pendant Adapter

- Let the cables pass through the rubber sealing ring, and then mount the sealing ring on IR speed dome. Then mount the IR PTZ speed dome camera on the pendant adapter.

WARNING: The pre-installed *sealing ring* is required to maintain IP66 rating.

To install the RJ-45 cable:

- Pierce a hole through one of the holes on the sealing ring.



- To facilitate inserting the RJ-45 cable through the hole, cut the edge of the CAT cable at a 45° angle.



Note: Do not cut the sealing ring to install the RJ-45 cable; this will void the IP66 protection and cause water leakage.

- Push the cable through the hole on the sealing ring.



Note: The sealing ring is not intended to prevent standing water or water dripping down from the pipe from entering the unit; make sure installation does not allow water to accumulate from the top.

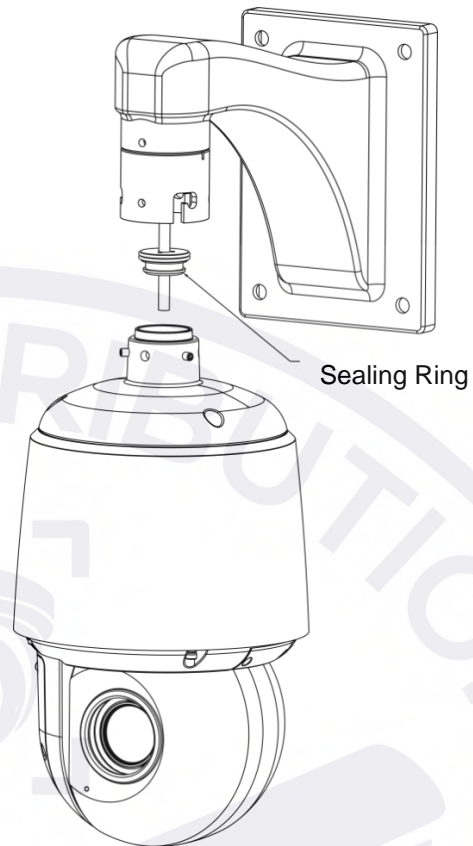

Figure 2 - 3: Mounting the Camera

- Fasten the 3 T20 stop screws with the T20 torx wrench.

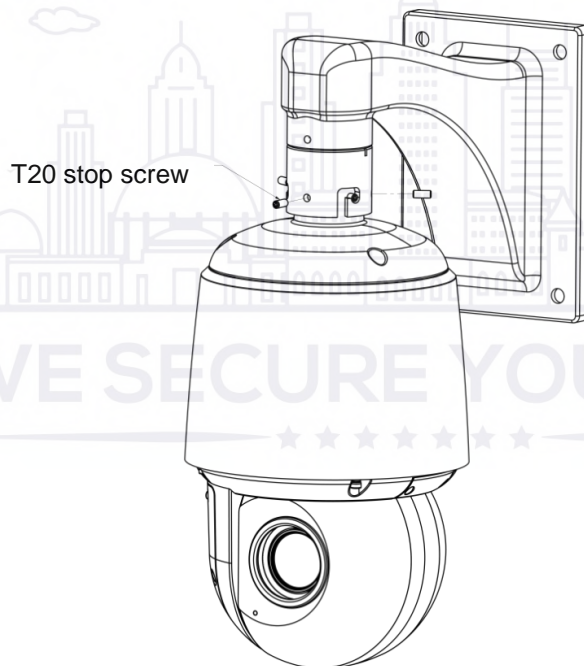

Figure 2 - 4: Fastening the 3 T20 Stop Screws

2.2.4 Connecting the Cables

1. Loosen the 2 T20 screws on top cover with the T20 torx wrench and then carefully allow the camera body shift downward.

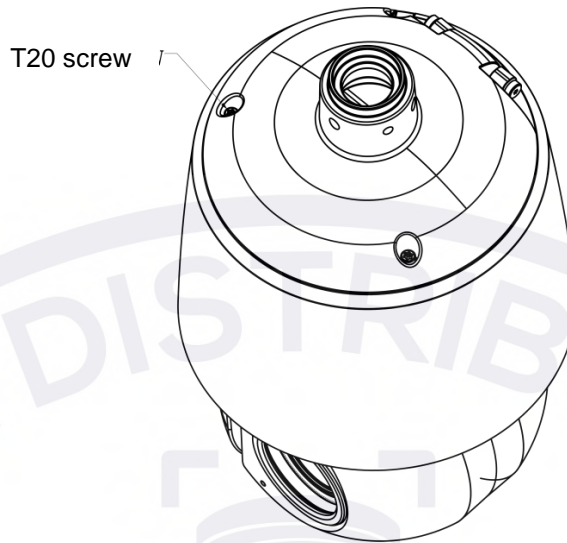

Figure 2 - 5: Loosening the 2 T20 Screws on Top Cover

With the camera body shifted downward, the I/O interfaces will be seen on the back of the camera module. Make the appropriate cable connections

2. Based on your needs, connect the power cable to the power port via one of the following 3 options.
 - **24 VAC:** Connect a power cable that supplies 24 VAC power source to the power terminal.
 - **48 VDC:** Connect a power cable that supplies 48 VDC power source to the power terminal.

NOTE: The polarities should match when using 48 VDC power source.

- **PoE (Class 6):** Connect an Ethernet cable terminated with a RJ-45 connector to the PoE RJ-45 port for both power supply and network connectivity.
3. Insert audio in/out cables and alarm in/out cables to the corresponding terminals of the camera if required.

NOTE: It is recommended to connect external microphones to ground (GND) on the digital I/O connector.

4. Refer to Figure 1 - 3: Internal Interface Pictorial Index for details on I/O interface.

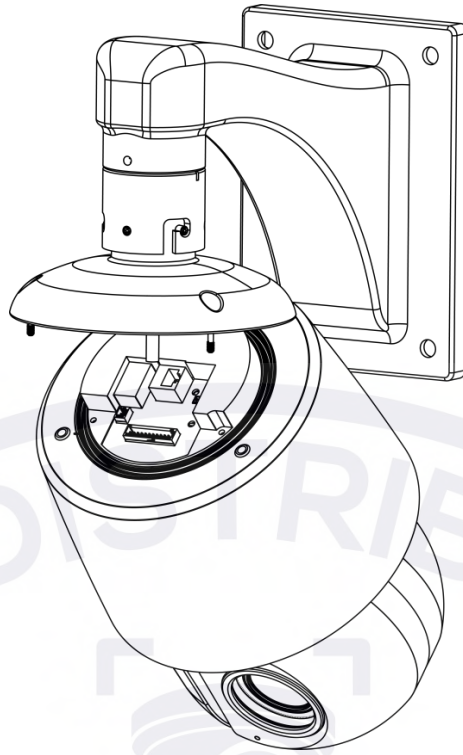

Figure 2 - 6: Connecting the Cables

5. After connecting the cables, shift the camera body upward and then tighten the 2 T20 screws on top cover with T20 torx wrench to complete the installation of the camera with wall mount.

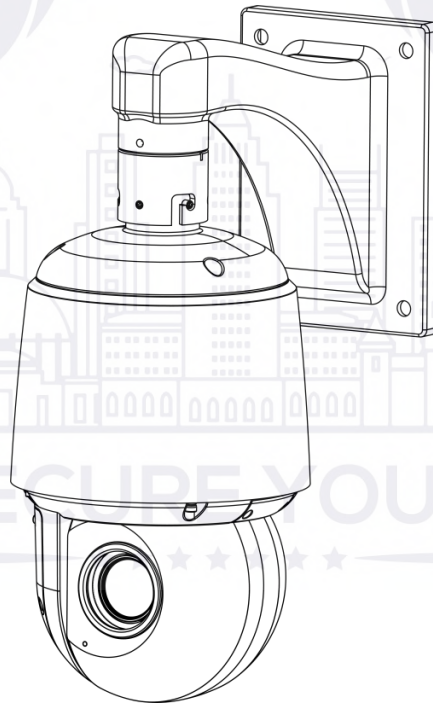

Figure 2 - 7: Completing the Camera Installation

3 Connection

3.1 Network Topology

The camera, which is equipped with Ethernet RJ-45 network interface, can deliver live view image in real time via both Internet and Intranet manners. Please refer to the skeleton drawings shown below for understanding.

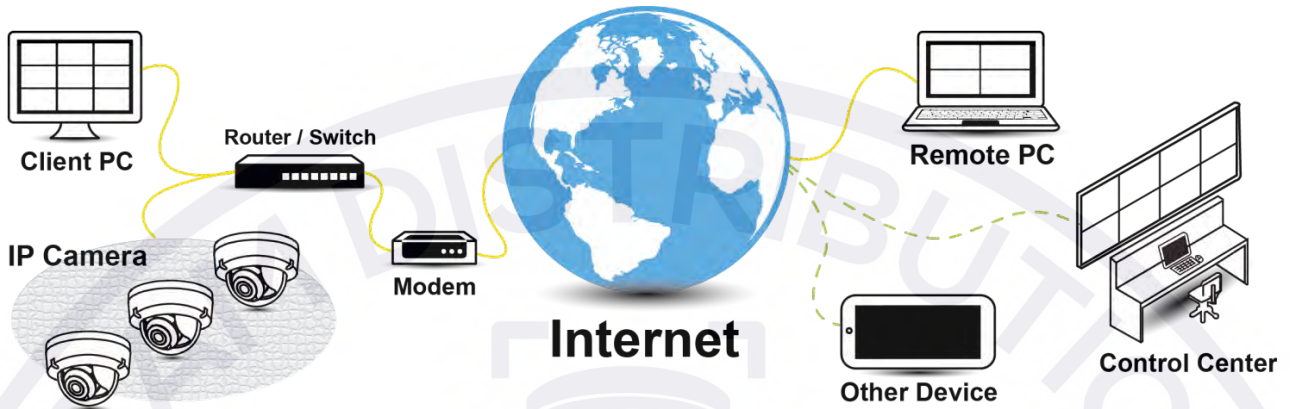

Figure 3 - 1: Network Topology

3.2 System Requirements

The table below lists the minimum requirements to implement and operate the camera. It is recommended not to use any hardware/software component below these requirements for proper performance.

Table 3 - 1: System Requirements

System Hardware	
CPU	i5-2430M CPU@ 2.40GHZ 2.40GHZ
RAM	6 GB or above
Display	NVIDIA GeForce 6 Series or ATI Mobility Radeon 9500
System Software	
Operating System	Windows 7 SP1, Windows 8, Windows 10
Browser	Internet Explorer 11, Mozilla Firefox, Chrome, Safari, Microsoft Edge
Unit	
Power Supply	24 VAC/48 VDC/PoE (IEEE 802.3bt Class 6)
Networking	
Wired*	10/100BASE-T Ethernet (RJ-45 connector)

*A switch is required for surveillance on multiple cameras.

Note All the installation and operations should comply with your local electricity safety regulations.

Caution When using PoE, this camera is to be connected only to PoE networks without routing to any heterogeneous devices. A heterogeneous network is a network connecting computers and other devices where the operating systems and protocols have significant differences.

3.3 Connecting Process

3.3.1 Default IP address

Since this is a network-based camera, an IP address must be assigned. The camera's default IP address is obtained automatically through a DHCP server in your network; be sure to enable DHCP in "Network Settings." If DHCP is not available, the camera will use APIPA (link-local address); IPv4 link-local addresses are assigned from address block 169.254.0.0/16 (169.254.0.0 through 169.254.255.255).

3.3.2 Connecting from a Computer & Viewing Preparation

Connecting from a computer

1. Make sure the camera and your computer are in the same subnet.
2. Check whether the network available between the camera and the computer by executing ping the default IP address. To do this, simply start a command prompt (Windows: from the "Start Menu", select "Program". Then select "Accessories" and choose "Command Prompt"), and type "Ping" and then type in your IP address. If the message "Reply from..." appears, it means the connection is available.
3. Start a browser e.g., Internet Explorer and enter IP address. A login window as shown below should pop up. In the window, enter the default user name: **ADMIN**; it is required to change the password when you login for the first time for added security, which requires at least 8 characters including 1 uppercase letter, 1 special character, alphanumeric characters to log in.
4. Further administration on the unit can be found in "**User Manual**".

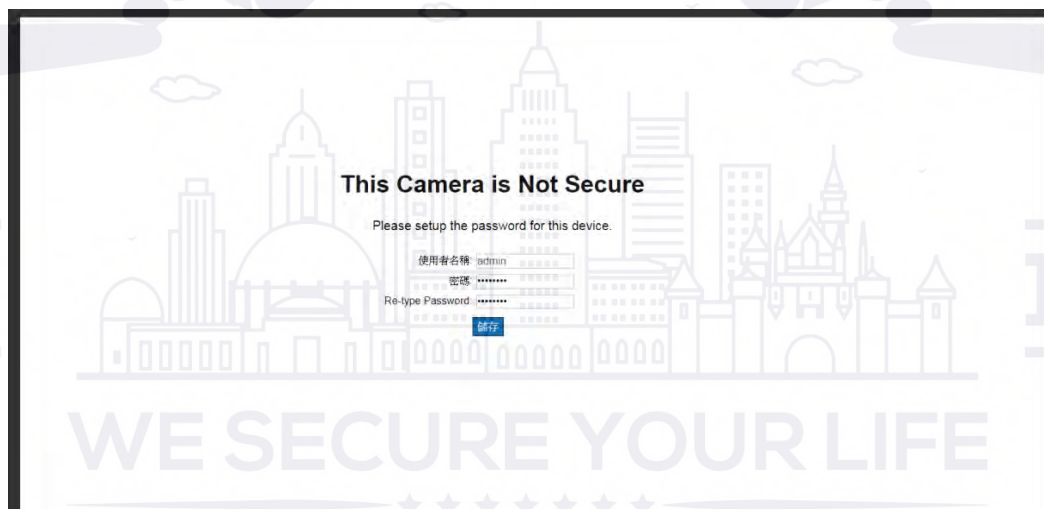

Figure 3 - 2: Login Window

Viewing Preparation

Images of the unit can be viewed through various browsers. Before viewing, follow these steps to enable the display.

1. Enable Cookies as instructions below
 - In Internet Explorer, click **Internet Options** on the **Tools** menu.
 - On the **Privacy** tab, move the settings slider to **Low** or **Accept All Cookies**.
 - Click **OK**.
2. When a proxy server is used, click **Internet Options** on the Tools menus of Internet Explorer, select **Connect** tab, click **LAN** button, and set proxy server.
3. Change Security in Internet options as instructions below
 - On tool menu, click **Internet Options**.
 - Press the **Security** tab.
 - If the camera operates inside of the intranet, click the **Intranet** icon.
 - If the camera operates outside of the intranet, click the **Internet** icon.
 - Click **Custom Level**. This will open the Security Settings – Internet Zone screen.

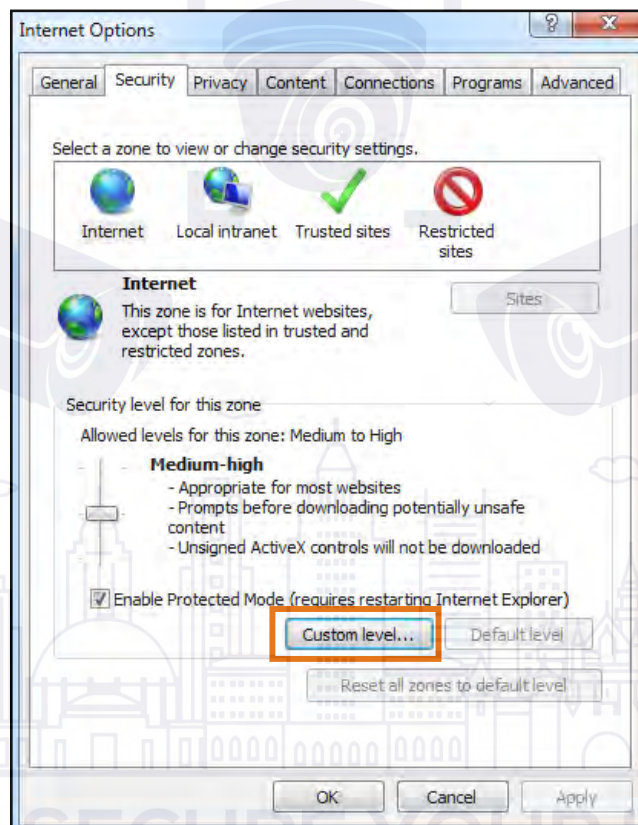

Figure 3 - 3: Security Settings 1/4

- Scroll down to the ActiveX controls and plug-ins radio buttons and set as follows:
 - 【Download signed ActiveX controls】 → Prompt (recommended)
 - 【Download unsigned ActiveX controls】 → Prompt
 - 【Initialize and script ActiveX not marked as safe for scripting】 → Prompt

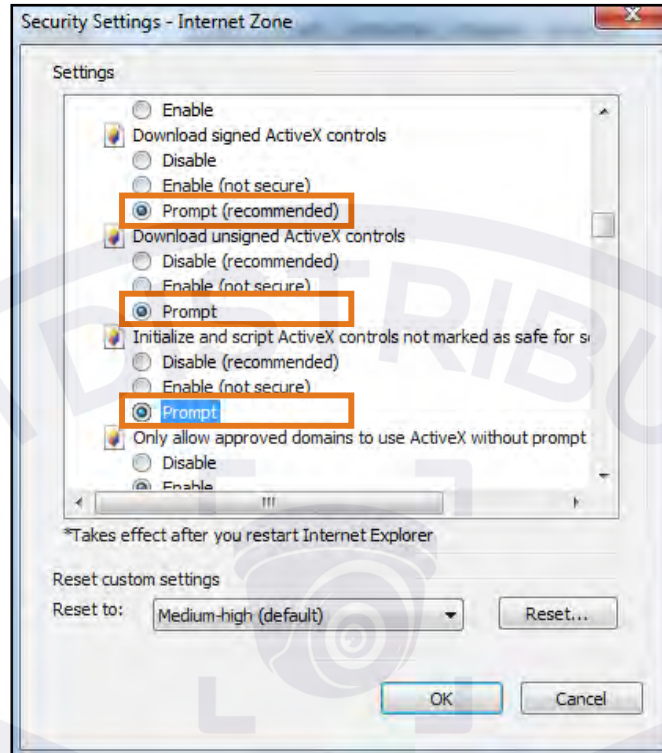

Figure 3 - 4: Security Settings 2/4

- 【Automatic prompting for ActiveX controls】 → Enable

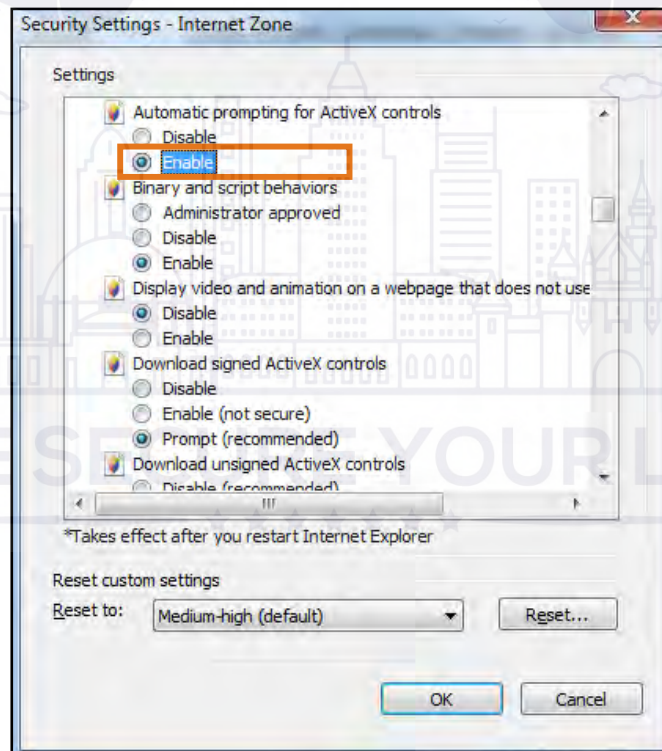

Figure 3 - 5: Security Settings 3/4

【Run ActiveX controls and plug-ins】 → Enable

【Script ActiveX controls marked safe for scripting*】 → Enable

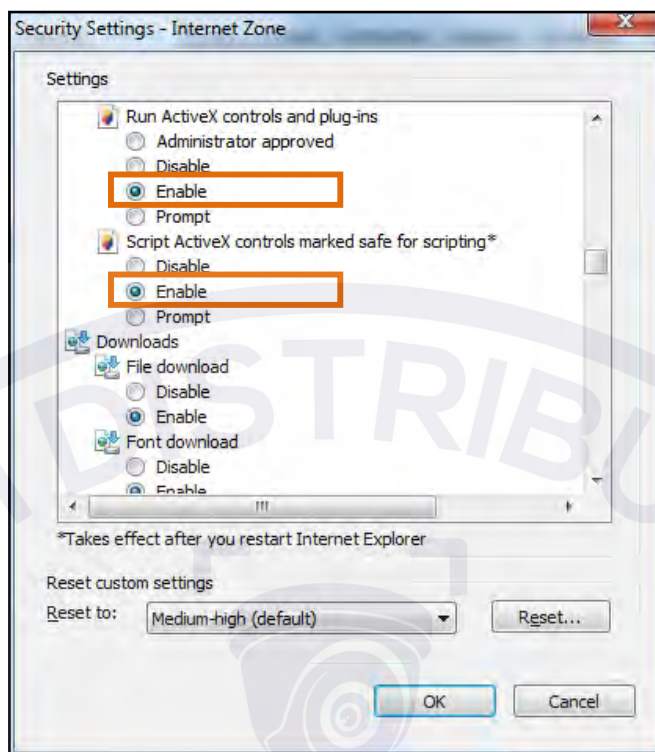

Figure 3 - 6: Security Settings 4/4

- Press **OK** to save the settings.
- Close all the browser windows and restart the browser. This will allow the new settings taking effect.
- Type your IP address into the browser.
- You should be able to see the camera image screen.

3.4 IP Toolbox

IP Toolbox is a utility program that helps users to locate the camera(s) in local area network that computer is connected to. Please note that IP Toolbox works only in Microsoft Windows XP, Microsoft Windows Vista, and Microsoft Windows 7 or above. Steps to get the utility program running are listed below.

1. Download the IP Toolbox's folder to local computer. The latest IP Toolbox can be found on Vicon's website Camera Software Download page, vicon-security.com.
2. Double click on **IPToolbox.exe** in the IP Toolbox's folder, and the IP Toolbox window should pop out as below.

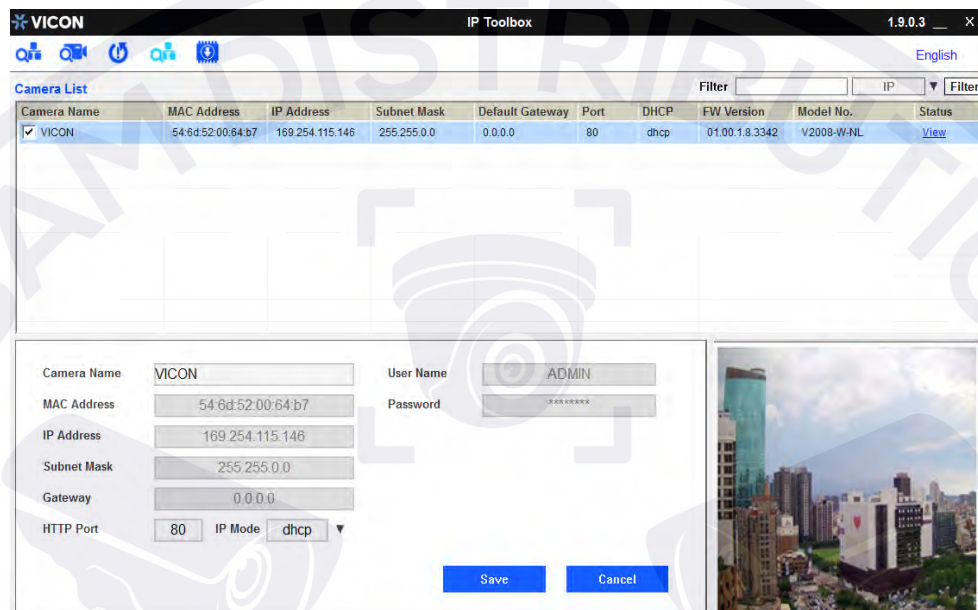



Figure 3 - 7: IP Toolbox

3. The window lists information of camera(s) in operation at the present time. Click the camera in the list for which you want to configure the network settings.
4. Configure the following settings as needed.
 - **User Name & Password:** Before performing any operation to any listed camera, please enter username and password for the selected camera, and then click **“Verify”** for authentication purposes.
 - **Camera Name:** Enter a descriptive name for the camera.
 - **Network Settings:** If you have a DHCP server on your network to assign IP addresses to network devices, enable the “dhcp” option from dropdown menu of **IP MODE**. Otherwise, select “manual” to manually enter the values for **IP Address**, **Subnet Mask**, **Gateway** and **HTTP Port** fields.
 - Click **“Save”** to enable the settings. Click **“Cancel”** to discard the settings.
5. Press **“View”** button; the designated browser page of the selected camera will pop out. Please input the corresponding **User Name & Password** to log in to the specific page of camera.
6. Press **“Refresh”** button; all the cameras currently connected to the network will appear on the list.
7. Press **“Initialize”** button; there are three options, Software default, Hardware default, and Reboot camera, for user to perform the factory default or reboot the camera. After clicking the preferred item, the warning message will appear. Please confirm again before you perform the selected function.

8. The **“Filter”** button on the upper-right corner allows user to perform filtering search, which means you can input certain keywords into the field nearby and also narrow down the range by selecting the criteria from the dropdown menu for a target search on cameras connected.
9. Press  **“Auto Set IP Address”** button to automatically give each camera an IP address from predefined range and connected to predefined network internet controller.
 - **User Name & Password:** Enter username and password for the current auto set IP address setting.
 - **Network Interface Controller:** Select desired network interface controller that each camera(s) will be connected to, and also select the IP address and IP address range of the controller.

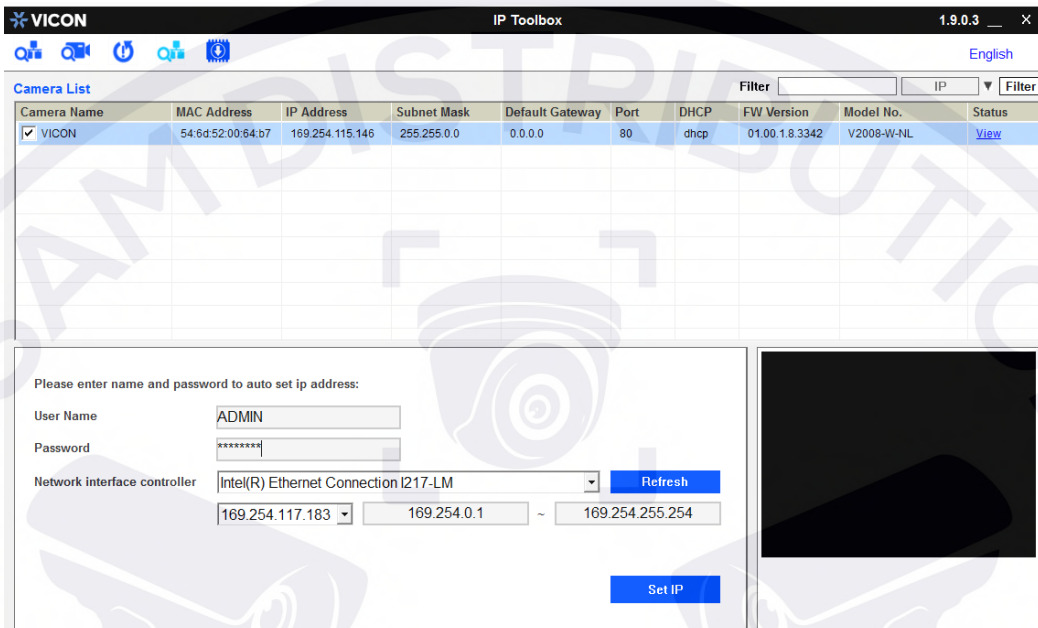



Figure 3 - 8: Auto Set IP Address

10. Click  “FW Upgrade” button to upgrade the firmware of selected camera. A pop up window like the image below will show up.

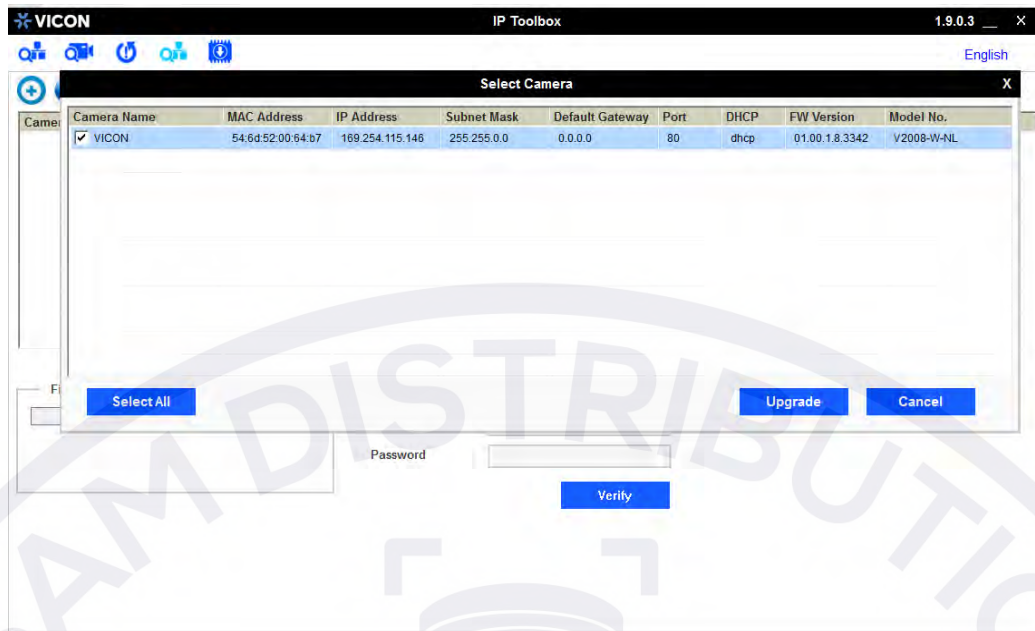





Figure 3 - 9: IP Toolbox FW Upgrade

Follow the steps below to complete firmware upgrade:

- Click  or  to add or remove camera to be upgraded (only verified cameras will be shown on this list).
- Select a camera or click “**Select All**” button to select a camera or all the cameras on the firmware upgrade list, respectively.
- Click “**Add**” or “**Cancel**” button to confirm the selected cameras for upgrade or to cancel the selection, respectively.
- Enter the path for the desired firmware (.tar) or click ; then follow the instructions to find and upload the .tar file.
- When the process is complete, click  again to return to the list of all cameras located in the local network

Appendix

Security Cameras and Lightning Protection Reference

Devices such as security cameras may be likely exposed to lightning strikes when installed outside of a building. It's recommended to perform some form of protection using a lightning rod on outdoor security cameras. The following drawing illustrates typical installation instructions of outdoor security cameras with lightning rod.

Note: The following drawings are meant as a general guide. Please refer to the lightning protection equipment manufacturer's installation instructions.

Note: The lightning protection equipment is not provided by Vicon. The camera must be installed by qualified service personnel in accordance with all local and federal electrical and building codes.

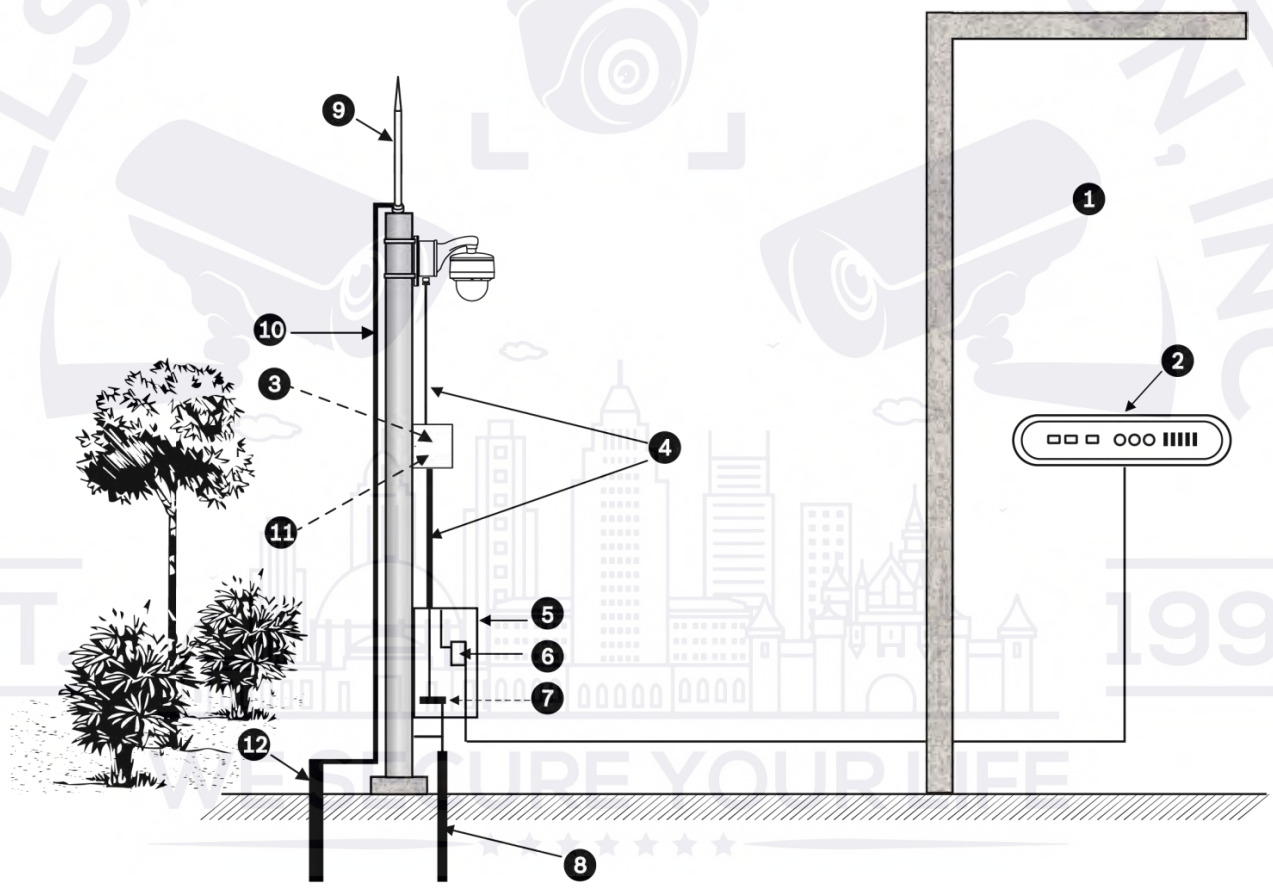

1.	Indoor building	2.	Network termination location
3.	Connect the ground cable of camera to the ground cable of Electrical ARC Protection Device.	4.	Install Ethernet cable. Pass the cable through grounded metal conduit.
5.	Equipment enclosure	6.	Mid-span; power output must meet requirements for the camera.
7.	Connect the bus bar to the grounding electrode.	8.	Grounding electrode of device
9.	Lightning Rod	10.	Ground cable
11.	Electrical ARC Protection Device. Install as close to the camera as possible and make sure it's connected to the grounding electrode.	12.	Grounding electrode of Lightning Rod

