

DH-EPC230U

2MP 30x Explosion-proof IR Network Camera

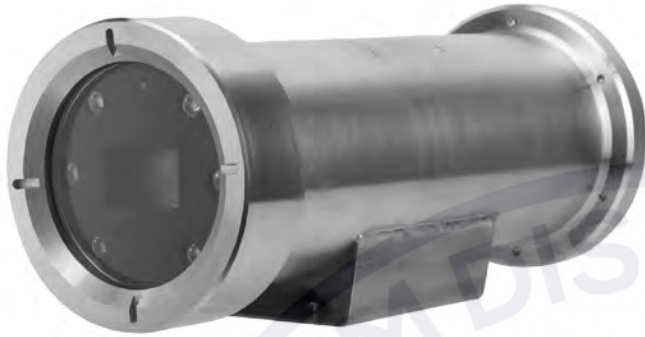

- 1/2.8" 2Megapixel STARVIS™ CMOS
- Powerful 30x optical zoom
- 304 stainless steel housing
- Starlight technology
- H.265 Encoding
- Max. 50/60fps@1080P
- Support IVS
- IR distance up to 100m
- IP68, ATEX and IECEx Certification

System Overview

Featuring powerful optical zoom, this camera provides an all-in-one solution for capturing long distance video surveillance for outdoor applications. Together with infrared illumination and Starlight technology, the camera is the perfect solution for dark, lowlight applications. The series combines a day/night mechanical IR cut filter for the highest image quality in variable lighting conditions during the day, and True WDR for applications with direct sunlight or glare.

Functions

Starlight Technology

For challenging low-light applications, Dahua's Starlight Ultra-low Light Technology offers best-in-class light sensitivity, capturing color details in low light down to 0.005 lux. The camera uses a set of optical features to balance light throughout the scene, resulting in clear images in dark environments.

Wide Dynamic Range

The camera achieves vivid images, even in the most intense contrast lighting conditions, using industry-leading wide dynamic range (WDR) technology. For applications with both bright and low lighting conditions that change quickly, True WDR (120 dB) optimizes both the bright and dark areas of a scene at the same time to provide usable video.

Smart H.265+

Smart H.265+ is the optimized implementation of the H.265 codec that uses a scene-adaptive encoding strategy, dynamic GOP, dynamic ROI, flexible multi-frame reference structure and intelligent noise reduction to deliver high-quality video without straining the network. Smart H.265+ technology reduces bit rate and storage requirements by up to 70% when compared to standard H.265 video compression.

PFA Technology

PFA technology has innovatively introduced new methods of judgment to ensure the accuracy and predictability of the direction of subject distance adjustment. The result is a set of advanced focusing algorithms. PFA ensures clarity of the image throughout the process of zooming and shortens focus time. The realization of PFA technology substantially improves user experience and increases product value.

Environmental

Dahua cameras operate in extreme temperature environments, rated for use in temperatures from -40 °C to +60 °C (-40 °F to +140°F) with 95% humidity. Subjected to rigorous dust and water immersion tests and certified to the IP68 Ingress Protection rating makes it suitable for demanding outdoor applications.

Protection

The camera allows for ±25% input voltage tolerance, suitable for the most unstable conditions for outdoor applications. Its 6KV lightning rating provides effective protection for both the camera and its structure against lightning.

Interoperability

The camera conforms to the ONVIF (Open Network Video Interface Forum) and PSIA (Physical Security Interoperability Alliance) specifications, ensuring interoperability between network video products regardless of manufacturer.

Technical Specification

Camera

Image Sensor	1/2.8" STARVIS™ CMOS
Effective Pixels	1920(H) x 1080(V), 2 Megapixels
RAM/ROM	512M/128M
Scanning System	Progressive
Electronic Shutter Speed	1/1s~1/30,000s
Minimum Illumination	Color: 0.005Lux@F1.6; 0Lux@F1.6 (IR on)
S/N Ratio	More than 55dB
IR Distance	Distance up to 100m (328ft)
IR On/Off Control	Auto/Manual
IR LEDs	6

Lens

Focal Length	4.5mm~135mm
Max. Aperture	F1.6 ~ F4.4
Angle of View	H: 67.8° ~ 2.4°
Optical Zoom	30x
Focus Control	Auto/Manual
Close Focus Distance	100mm~ 1000mm

DORI Distance

*Note: The DORI distance is a “general proximity” of distance which makes it easy to pinpoint the right camera for your needs. The DORI distance is calculated based on sensor specification and lab test result according to EN 62676-4 which defines the criteria for Detect, Observe, Recognize and Identify respectively.

Detect	Observe	Recognize	Identify
1862m(6109ft)	744m(2441ft)	372m(1220ft)	186m(610ft)

Intelligence

Auto Tracking	N/A
IVS	Tripwire, Intrusion, Abandoned/Missing, Face Detection, Heat Map

Video

Compression	H.265+/H.265/H.264+/H.264
Streaming Capability	3 Streams
Resolution	1080P(1920×1080)/1.3M(1280×960)/720P(1280×720)/D1(704×576/704×480)/CIF(352×288/352×240)
Frame Rate	Main stream: 1080P/1.3M/720P(1~50/60fps)
	Sub stream1: D1/CIF(1 ~ 25/30fps)
	Sub stream2: 1080P/1.3M/720P/D1/CIF (1~25/30fps)
Bit Rate Control	CBR/VBR
Bit Rate	H.265/H.264: 448K ~ 8192Kbps
Day/Night	Auto(ICR) / Color / B/W

Backlight Compensation	BLC / HLC / WDR (120dB)
White Balance	Auto, ATW, Indoor, Outdoor, Manual
Gain Control	Auto / Manual
Noise Reduction	Ultra DNR (2D/3D)
Motion Detection	Support
Region of Interest	Support
Electronic Image Stabilization (EIS)	Support
Defog	Support
Digital Zoom	16x
Flip	180°
Privacy Masking	Up to 24 areas

Audio

Compression	G.711a/G.711Mu/AAC/G.722/G.726/MPEG2-L2
-------------	---

Network

Ethernet	RJ-45 (10Base-T/100Base-TX)
Protocol	IPv4/IPv6,HTTP,HTTPS,SSL,TCP/IP, UDP,UPnP, ICMP,IGMP,SNMP,RTSP,RTP, SMTP, NTP,DHCP, DNS,PPPOE,DDNS,FTP, IP Filter,QoS,Bonjour,802.1x
Interoperability	ONVIF, PSIA, CGI
Streaming Method	Unicast / Multicast
Max. User Access	20 users
Edge Storage	NAS (Network Attached Storage),Local PC for instant recording, Micro SD card 128GB
Web Viewer	IE, Chrome, Firefox, Safari
Management Software	Smart PSS, DSS
Smart Phone	IOS, Android

Certifications

Certifications	CE: EN55032/EN55024/EN50130-4 FCC: Part15 subpartB, ANSI C63.4- 2014 ATEX: EN 60079-0/EN 60079-1/EN 60079-31 IECEX : IEC 60079-0/IEC 60079-1/IEC 60079-31
Explosion-proof Marking	ATEX: II 2 G Ex db IIC T6 Gb, II 2 D Ex tb IIIC T80°C Db IECEX : Ex db IIC T6 Gb, Ex tb IIIC T80°C Db

Interface

Video Interface	1 port(BNC, 1.0V[p-p], 75Ω)
RS485	1
Audio I/O	1/1
Alarm I/O	2/1

Electrical

Power Supply	AC220V(AC100V ~ 240V), Hi-PoE
Power Consumption	10W, 25W (IR on)

Environmental

Operating Conditions	-40°C ~ 60°C (-40°F ~ +140°F) / Less than 95% RH
Ingress Protection	IP68
Vandal Resistance	N/A

Construction

Casing	304 Stainless Steel
Dimensions	Φ396.1mm×149.5mm×143mm
Net Weight	8.7kg(19.18lb)
Gross Weight	10.4kg(22.93lb)

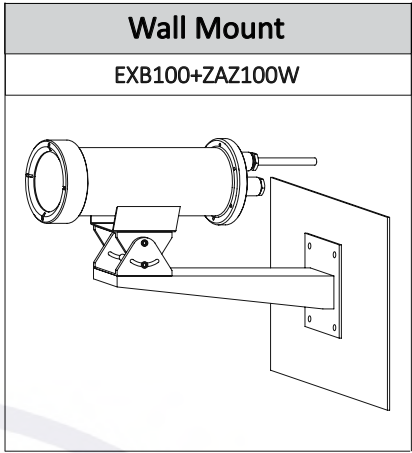

Ordering Information

Type	Part Number	Description
2MP Camera	DH-EPC230U	2MP 30x Explosion-proof IR Network Camera, WDR, PAL
	DH-EPC230UN	2MP 30x Explosion-proof IR Network Camera, WDR, NTSC
Accessory	DH-ZAZ100W	Mount Adapter
	DH-EXB100	Wall Mount
	DH-ZA-JXD4	Junction Box (Φ227mm×84mm)
	DH-ZAJ300	Junction Box (Φ376mm×175mm)
	DH-GE1500	Flexible Tube

Dimensions (mm)

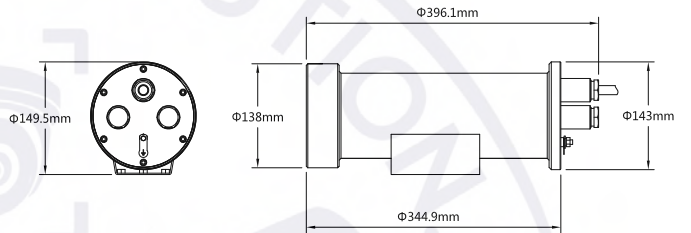

Accessories

Optional:



DH-ZAZ100W
Mount Adapter



DH-EXB100
Wall Mount



DH-ZA-JXD4
Junction Box



DH-ZAJ300
Junction Box



DH-GE1500
Flexible Tube

1998

WE SECURE YOUR LIFE

