

Roughneck AI V2360W-12-1

AI ANALYTICS INSIDE

Outdoor Panoramic Camera



 **NDA**  **GSA**  **ONVIF**  **TAA**
S/G/T/M



Cybersecurity Notification: All network connected devices should use best practices for accessing the device. To that end, these network cameras do not have a default password. A user defined password with minimum password strength requirements must be set to access the device. **See page 13** of this Quick Guide for set-up instructions.



Table of Contents

1	Product Overview	4
1.1	Physical Characteristics	4
2	Installation, Mounting and Connections	8
2.1	Package Contents	8
2.2	Installation	8
2.2.1	Checking Appearance	8
2.2.2	Mounting Camera	9
3	Connection	12
3.1	Network	12
3.2	System Requirements	12
3.3	Connecting Process	13
3.3.1	Accessing the Camera	13
3.3.2	Connecting from a Computer	13
3.4	PRONTO Device Manager	14

EST.





1998

WE SECURE YOUR LIFE



WARNING

- This camera operates at 12 VDC/24 VAC/PoE+ (IEEE 802.3at Class 4).
- Installation and service should be performed only by qualified and experienced technicians and comply with all local codes and rules to maintain your warranty.
- We are NOT liable of any damage arising either directly or indirectly from inappropriate installation which is not depicted within this documentation.
- To reduce the risk of fire or electric shock, do not expose the product to rain or moisture.
- Wipe the camera with a dry soft cloth. For tough stains, slightly apply diluted neutral detergent and wipe with a dry soft cloth.
- Do not apply benzene or thinner to the camera, which may cause the surface to melt or lens fog.
- Avoid aligning the lens with extremely bright objects (e.g., light fixtures) for long periods of time.
- Although this camera is waterproof and suitable for both indoor and outdoor usages, do not immerse the camera into water.
- Avoid operating or storing the camera in the following locations:
 - Extremely humid, dusty, or hot/cold environments (recommended operating temperature: -40°F to +122°F/-40°C to +50°C)
 - Close to sources of powerful radio or TV transmitters
 - Close to fluorescent lamps or objects with reflections
 - Under unstable or flickering light sources

	CAUTION RISK OF ELECTRIC SHOCK DO NOT OPEN			THIS SYMBOL INDICATES THAT DANGEROUS VOLTAGE CONSTITUTING A RISK OF ELECTRIC SHOCK IS PRESENT WITHIN THE UNIT.
CAUTION: TO REDUCE THE RISK OF ELECTRIC SHOCK, DO NOT REMOVE THE COVER. NO USER-SERVICEABLE PARTS INSIDE. REFER SERVICING TO QUALIFIED SERVICE PERSONNEL.			THIS SYMBOL INDICATES THAT IMPORTANT OPERATING AND MAINTENANCE INSTRUCTIONS ACCOMPANY THIS UNIT.	



WEEE (Waste Electrical and Electronic Equipment). Correct disposal of this product (applicable in the European Union and other European countries with separate collection systems). This product should be disposed of, at the end of its useful life, as per applicable local laws, regulations, and procedures.

Get Started

This quick guide is designed as a reference for installation of the camera. For additional information on the camera's features, functions, and detailed explanation of the web interface controls, refer to User's Manual for details. Please read this quick guide thoroughly and save it for future use before attempting to install the camera. From this guide you will get:

- Product Overview: The physical parts, features and dimensions of the camera.
- Installation and Connection: The instructions on installation and wires connection for the camera.

FCC Compliance Statement



Information to the user: This unit has been tested and found to comply with the limits for a Class B digital device pursuant to Part 15 of the FCC Rules. Operation is subject to the following two conditions: (1) this device may not cause harmful interference, and (2) this device must accept any interference received, including interference that may cause undesired operation. These limits are designed to provide reasonable protection against harmful interference in a residential installation. This unit generates, uses, and can radiate radio frequency energy and, if not installed and used in accordance with the manual, may cause harmful interference to radio communications. However, there is no guarantee that interference will not occur in a particular installation.

If this unit does cause harmful interference to radio or television reception, which can be determined by turning the unit off and on, the user is encouraged to try to correct the interference by one or more of the following measures:

- Reorient or relocate the receiving antenna.
- Increase the separation between the unit and receiver.
- Connect the unit to an outlet on a circuit different from that to which the receiver is connected.
- Consult the dealer or an experienced radio/TV technician for help.

Caution Changes or modifications not expressly approved by the party responsible for compliance could void the user's authority to operate the unit.

CE Statement



Operation is subject to the following two conditions: (1) this device may not cause harmful interference, and (2) this device must accept any interference received, including interference that may cause undesired operation. The manufacturer declares that the unit supplied with this guide is compliant with the essential protection requirements of EMC directive and General Product Safety Directive GPSD conforming to requirements of standards EN55022 for emission, EN 50130-4 for immunity, EN 300 and EN 328 for WIFI.

This product is IP67 rated for outdoor environments and IK10 rate for impact protection. The camera also meets regulations required to be NDAA, GSA schedule and TAA approved.

1 Product Overview

1.1 Physical Characteristics

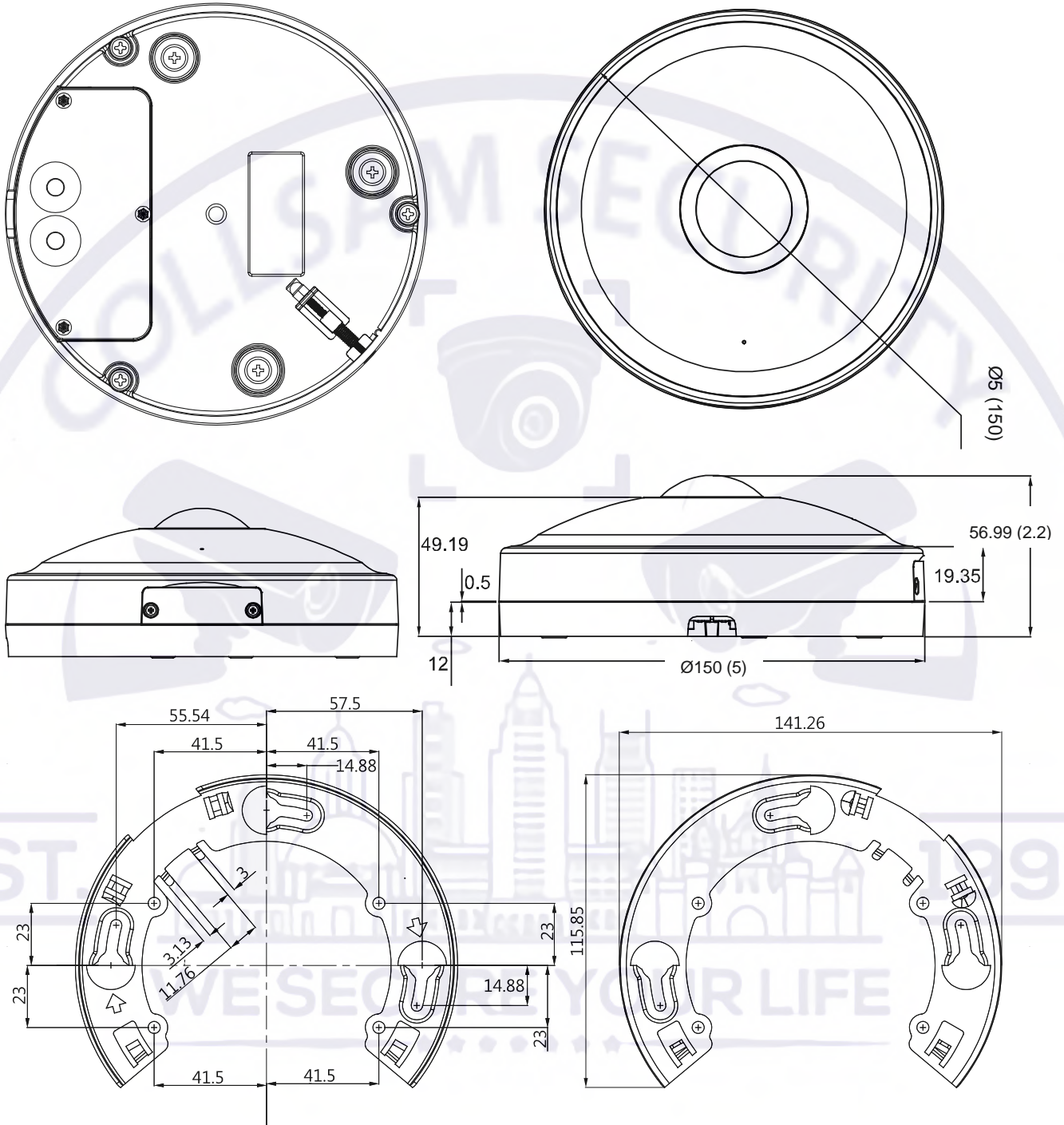

Figure 1 - 1: Physical Dimension

Unit: mm (in.)

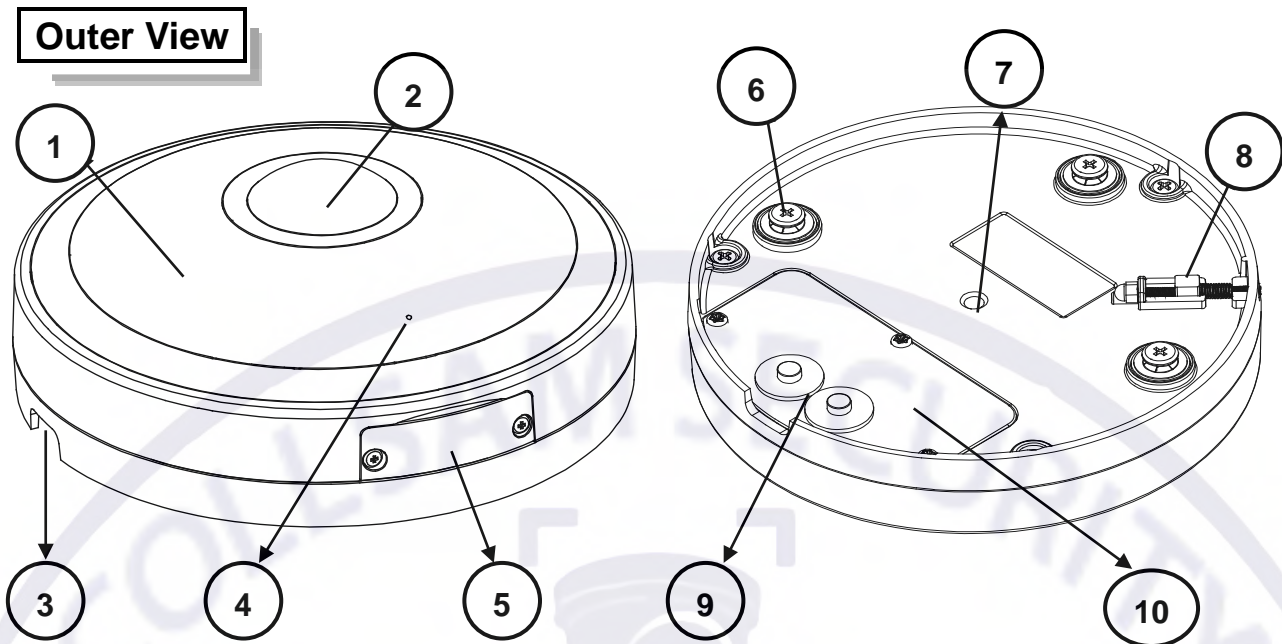

Figure 1 - 2: Outer View Pictorial Index

No	Name	Description
1	Dome Cover	The upper dome-shape cover provides protection
2	Lens	The proprietary fisheye lens provides wide hemispheric view
3	Cabling Cutout	The cutout hole for cables threading
4	Microphone Vent	The hole for built-in microphone to receive audio input
5	Side Cap	Loosen the 2 screws to open the side cap to access inner interfaces for use.
6	Mounting Screws	The 3 symmetrical screws designed for mounting with bracket
7	Mounting Thread Hole	With the standard female thread 1/4-20, the hole is for attaching an additional bracket (sold separately) for installation flexibility.
8	Security Lock	The proprietary security lock design ensures camera is mounted securely onto the bracket. Refer to the " Security Lock Settlement " chapter for details on how to properly set up.
9	Waterproof Grommet	The specifically designed dual waterproof grommet (rubber plug) allows multiple cables to thread through and provides waterproof function at the same time. Prior to threading, pull the rubber plug out. Seal the plug back to the position when no cable thread is in use.
10	Rear Cap	Loosen the 3 screws to open the rear cap to access the inner ports and interfaces for further use.

Table 1 - 1: Outer View Pictorial Index Definition

Inner View

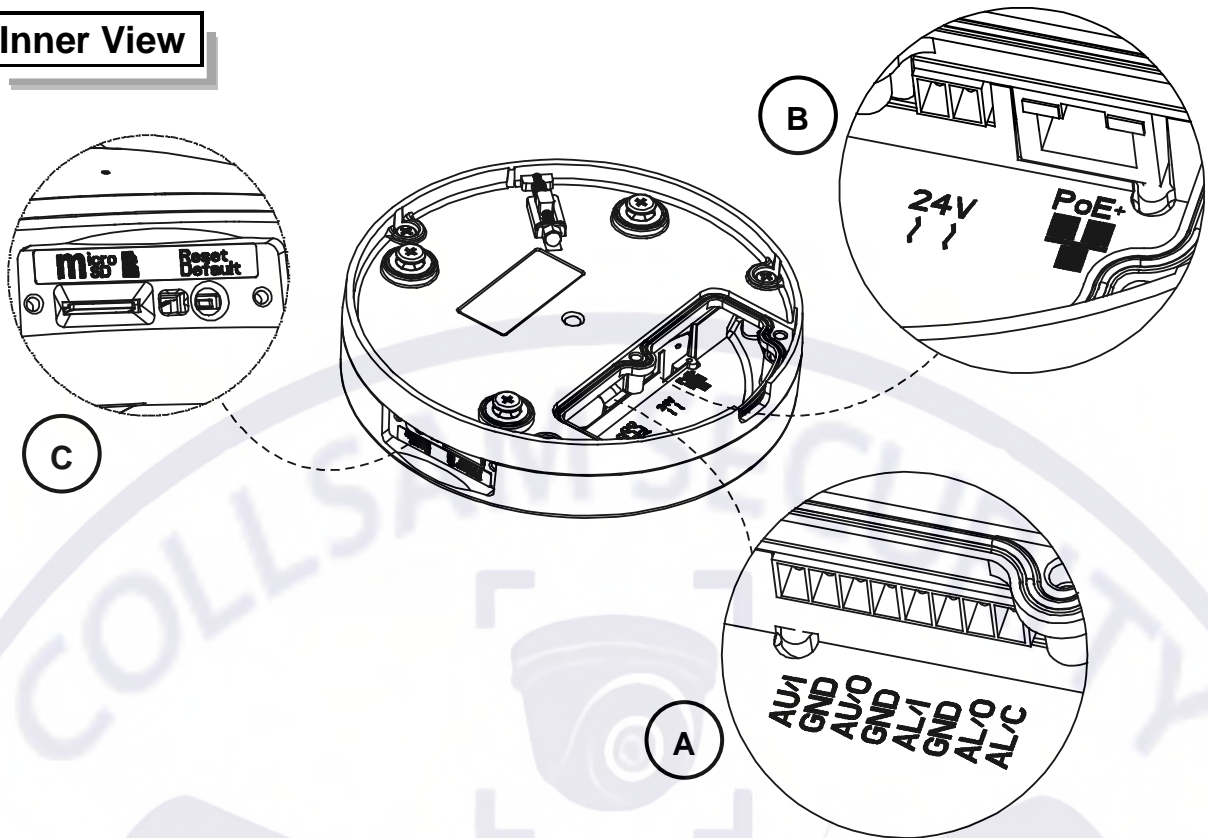

Figure 1 - 3: Inner View Pictorial Index

No	Interface	Description
A	DI/DO Terminal Ports	Connect to several external devices for audio and alarm input/output functions, which can expand usability of camera for a variety of field applications. Refer to Table 1 - 3 for details on port definitions.
B	RJ-45 PoE Port	Insert an Ethernet cable that connects with internet device into the PoE port for network connection and PoE (Power over Ethernet) capability.
	24 VAC/12 VDC Power Ports	To power on camera, connect 12 VDC or 24 VAC power source to the corresponding 2-pin ports. Pay attention to polarity while cabling 12 VDC power supply.
C	Reset & Default Button	Press the button for less than 1 second to reboot the camera; pressing for 6 seconds will restore the camera to the factory default settings.
	Micro SD Card Slot	Insert a micro SDHC/SDXC card (customer supplied) into the slot for recording and file storage

Table 1 - 2: Inner Interface Pictorial Index Definition

	Name	Port
	AUDIO IN	AU/I GND
	AUDIO OUT	AU/O GND
	ALARM IN	AL/I GND
	ALARM OUT	AL/O AL/C

Table 1 - 3: I/O Port Definitions

Note Power supply terminal/adaptor for IO connectors and field wiring should comply with the Class 2 Circuit standard for ensuring safety from electrical fires and providing acceptable protection against electrical shock.

The Alarm out pin is a 30 VDC output signal with a maximum load of 1 A.

The Alarm in pin acts as a switch, which is either NO (Normal Open) or NC (Normal Closed).

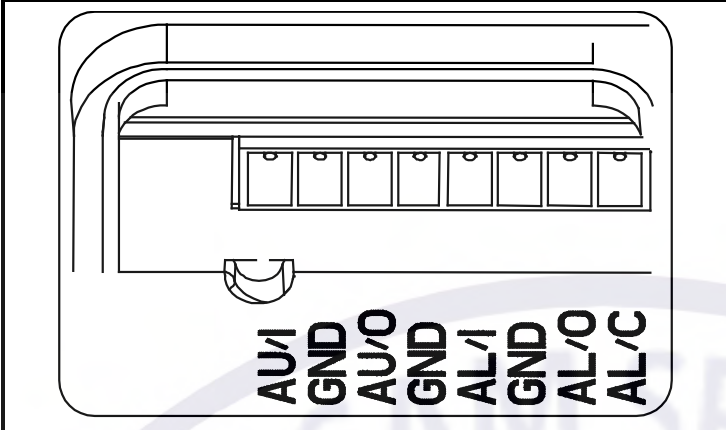

2 Installation, Mounting and Connections

2.1 Package Contents

Check if all items listed below are included in the packing box.

- Network Fisheye Camera * 1
- Flat Bracket * 1
- Safety Wire * 1
- Plastic Anchors * 4
- Tapping Screws * 4
- Torx Wrench * 1
- 2-pin Terminal Block * 1
- 8-pin Terminal Block * 1
- Printed Quick Guide * 1
- Guide Pattern * 1

2.2 Installation

The following tools might help you complete the process of installation:

- Drill
- Screwdrivers
- Wire Cutters

2.2.1 Checking Appearance

When unpacking, check to see if there is any visible damage to the appearance of the camera and its accessories. The protective materials used for the packaging should protect the camera from most accidents during shipment. Remove the protective materials from the camera after every item is properly checked in accordance with the list in **Package Contents**.

EST. 1998
WE SECURE YOUR LIFE

2.2.2 Mounting Camera

1. Attach the Guide Pattern to the mounting surface.

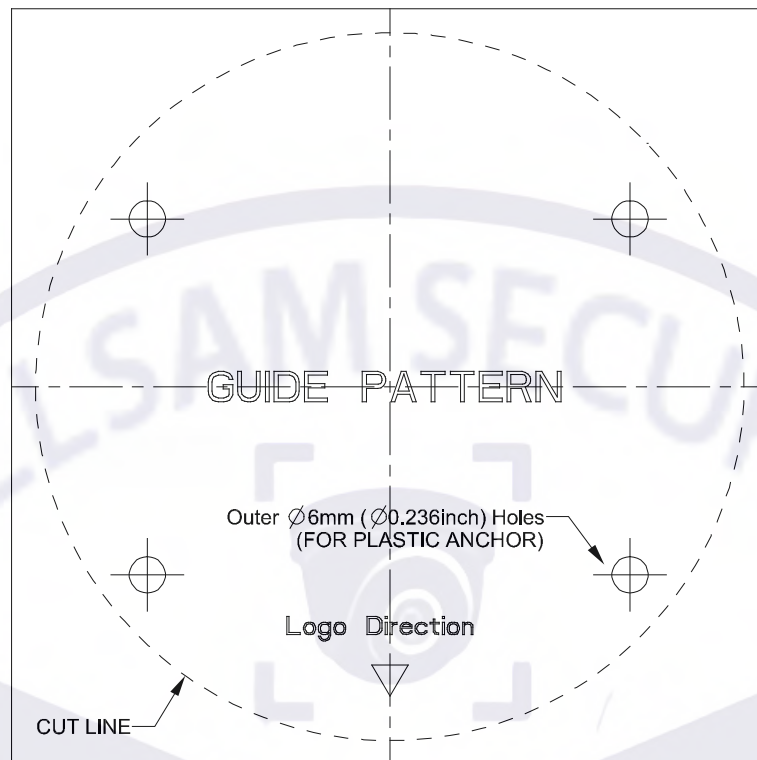

2. Drill 4 relative holes on a clean flat surface (ceiling or wall). Insert 4 plastic anchors into the drilled holes.
3. Attach the flat bracket onto the surface by fixing it tightly with the 4 screws (TP4).
Be sure to plug the drilled holes with the 4 plastic anchors prior to securing the bracket with the screws.
4. Open the rear cap by loosening the 3 screws. Connect the required cable threads as needed: 24 VAC/ 12 VDC power cord to the 2-pin power terminal, Ethernet cable to the PoE port, and the additional audio and alarm input/output cables to the 8-pin terminal block. Remove the rubber plug and insert the required jacketed cables through the waterproof grommet to ensure proper IP66 water ingress protection; terminate the cables. Note: do not slit or alter the grommet. If required, open the side cap by loosening the 2 screws and insert a customer-supplied Micro SDHC/SDXC card into the embedded slot. Restore each of the caps back to their positions and fasten the screws securely.

Caution: Fully tighten screws after installing cable and uSD card to ensure IP66 sealing of camera.

5. Attach the rear side of camera to the fixed flat bracket and align the 3 screws with the corresponding holes on the bracket as shown in figure below. Rotate the camera clockwise until it clicks into place so that camera will be firmly mounted onto the bracket. To disassemble, rotate the camera counterclockwise and remove it from bracket.

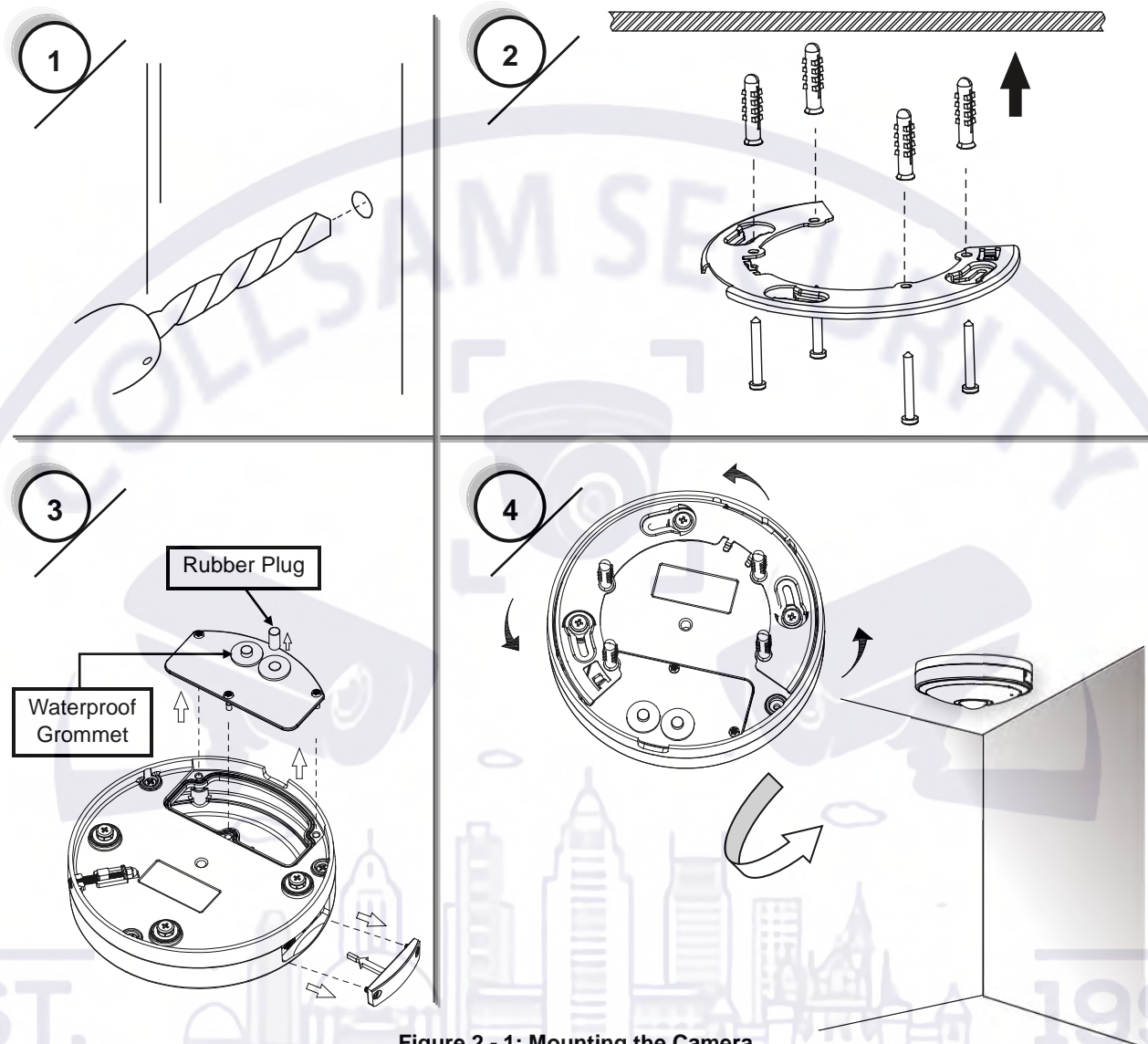

Figure 2 - 1: Mounting the Camera

Note: Feed the unterminated CAT5 cable through the hole in the solid grommet and terminate the cable with the appropriate connector.

To maintain watertight integrity/warranty, be sure to use the appropriate grommet. Jacketed cables with a diameter between 0.165-0.2 in. (4.2mm- 5mm) must be used.

Fully tighten screws after installing cables and uSD to ensure IP66 seal.

Note

- The correct size holes for TP4 screws with plastic anchors are of diameter ϕ 6.35 mm (0.25 in.).
- Seal up waterproof rubber hole with plug when no cable is in use.

Security Lock

After mounting the camera onto the flat bracket, bolt the security lock by fastening the security screw counterclockwise, as the figure shown below, so that camera will be mounted to bracket securely. To disassemble camera from flat bracket, loosen the security screw clockwise first.

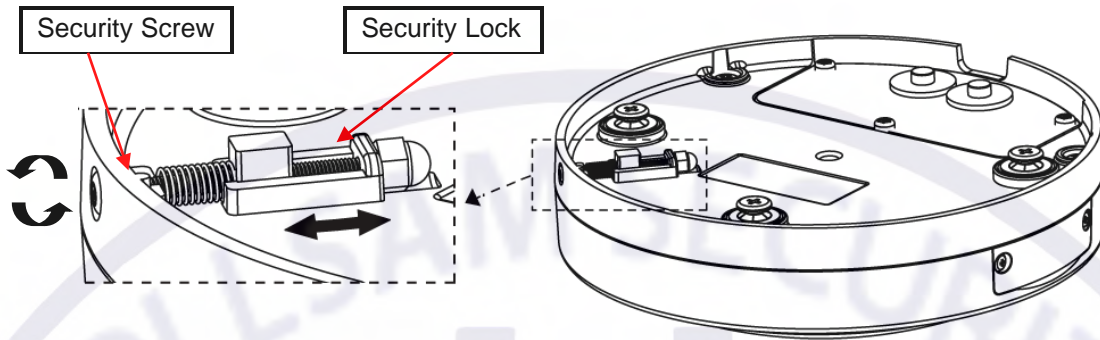

Figure 2 - 2: Security Lock Settlement

Safety Wire Preparation

In order to prevent the camera from accidentally falling, connect the included safety wire with one end on the mounted bracket and the other end to the safety-wire screw on the camera. Referring to the figure below, fasten the metal-circle end of wire with the safety-wire screw onto the rear side of camera and attach the other wire end to the hook of mounted bracket.

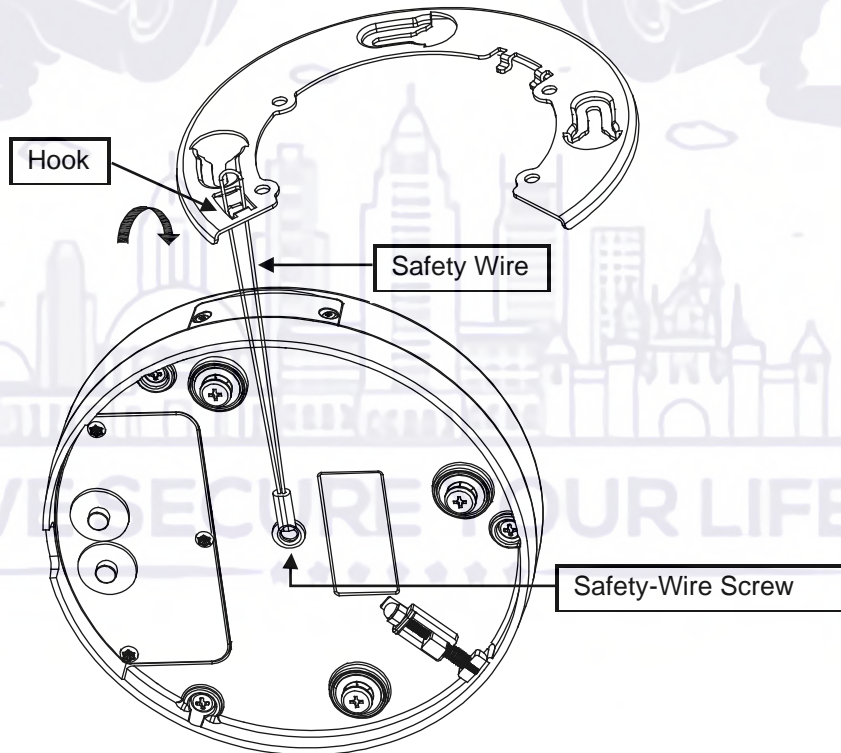

Figure 2 - 3: Safety Wire Connection

Note

Safety wire must be firmly connected with one end to the hook of bracket and the other end to the safety-wire screw of the camera to ensure anti-dropping function.

3 Connection

3.1 Network

The camera, which is equipped with Ethernet RJ-45 network interface, can deliver live view image in real time via both Internet and Intranet manners. Review the topology drawings shown below.

3.2 System Requirements

The table below lists the minimum requirement to implement and operate the camera. It is recommended not to use any hardware/software component below these requirements for proper performance.

Table 3 - 1: System Requirements

System Hardware	
CPU	i5-2430M CPU@ 2.40GHZ
RAM	6 GB or above
Display	NVIDIA GeForce 6 Series or ATI Mobility Radeon 9500
System Software	
Operating System	Windows 7 SP1, Windows 8, Windows 10
Browser	Mozilla Firefox, Chrome, Safari, Microsoft Edge
Unit	
Power Supply	24 VAC/12 VDC/PoE+ (IEEE 802.3at Class 4)
Networking	
Wired*	10/100BASE-T Ethernet (RJ-45 connector)

*A switch is required for surveillance on multiple cameras.

Note All the installation and operations should comply with your local electricity safety rules. When powering on via PoE+, this camera is to be connected only to PoE+ networks without routing to heterogeneous devices. A heterogeneous network is a network connecting computers and other devices where the operating systems and protocols have significant differences.

Caution

EST. 1998
WE SECURE YOUR LIFE

3.3 Connecting Process

3.3.1 Accessing the Camera

The camera can be accessed directly from its web page or using Vicon's PRONTO Device Manager, which can be found on Vicon's website. Note that when accessing the camera for the first time, a message will display to reset the password.

Since this is a network-based camera, an IP address must be assigned. The camera's default IP address is obtained automatically through a DHCP server in your network; be sure to enable DHCP in "Network Settings." If DHCP is not available, the camera will use APIPA (link-local address); IPv4 link-local addresses are assigned from address block 169.254.0.0/16 (169.254.0.0 through 169.254.255.255).

3.3.2 Connecting from a Computer

Connecting from a computer

1. Make sure the camera and your computer are in the same subnet.
2. Check whether the network available between the camera and the computer by executing ping the default IP address. To do this, simply start a command prompt (Windows: from the "Start Menu", select "Program". Then select "Accessories" and choose "Command Prompt"), and type Ping" and then type in your IP address. If the message "Reply from..." appears, it means the connection is available.
3. Start a browser e.g., Internet Explorer and enter IP address. A login window as shown below should pop up. In the window, enter the default user name: **ADMIN**; it is required to change the password when you login for the first time for added security, which requires at least 8 characters including 1 uppercase letter, 1 special character, alphanumeric characters to log in.

Further administration on the unit can be found in "User Manual".

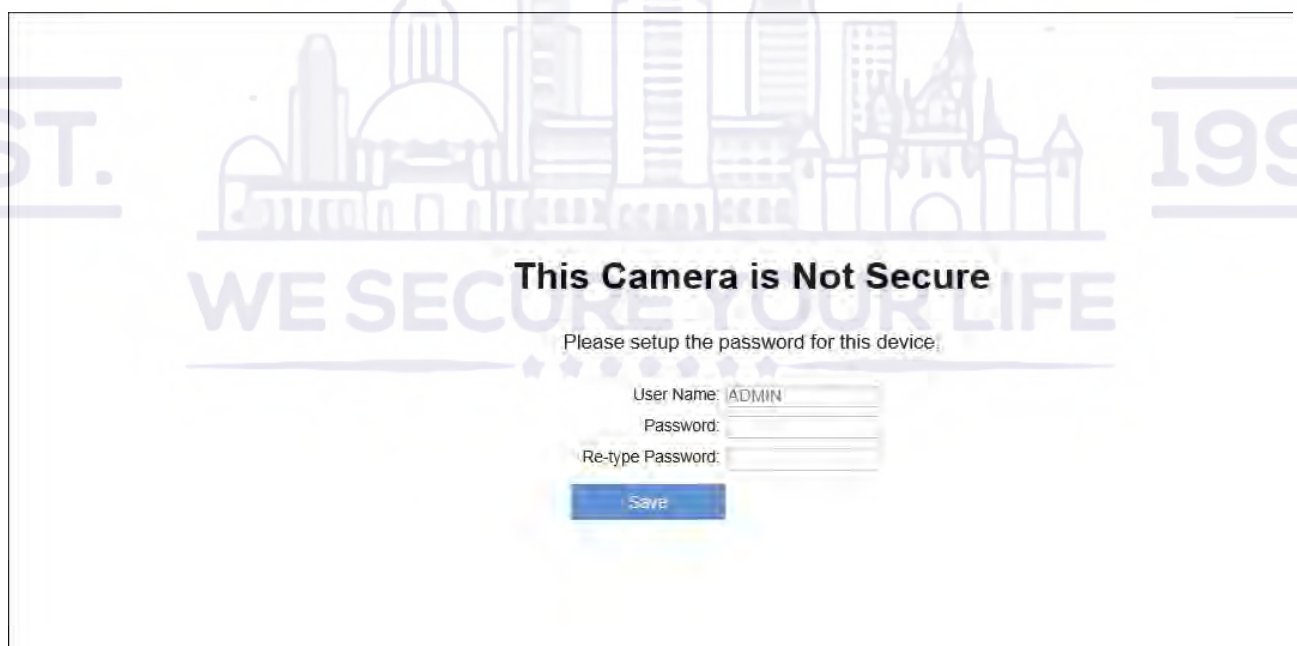

Figure 3 - 1: Login Window

3.4 PRONTO Device Manager

PRONTO is Vicon's device manager (Discovery tool) that can be used to discover all Vicon cameras on a system. The complete [User Manual](#) can be found on Vicon's website.

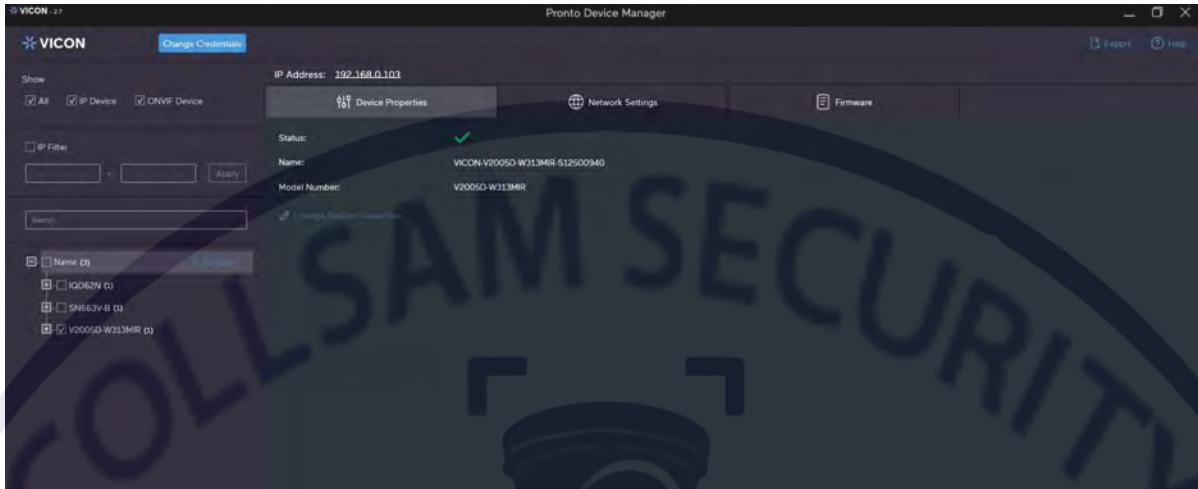

Figure 3 - 2: PRONTO Interface

- Upon startup of the PRONTO Device Manager, the tool's auto-discovery function generates a list of the discovered cameras on the network in a resource list.
- There are a variety of filtering options, including filter by All Devices/IP Device/ONVIF Device; IP range or text.
- There are tabs for Device Properties, Network Settings and Firmware.

EST.

1998

WE SECURE YOUR LIFE