

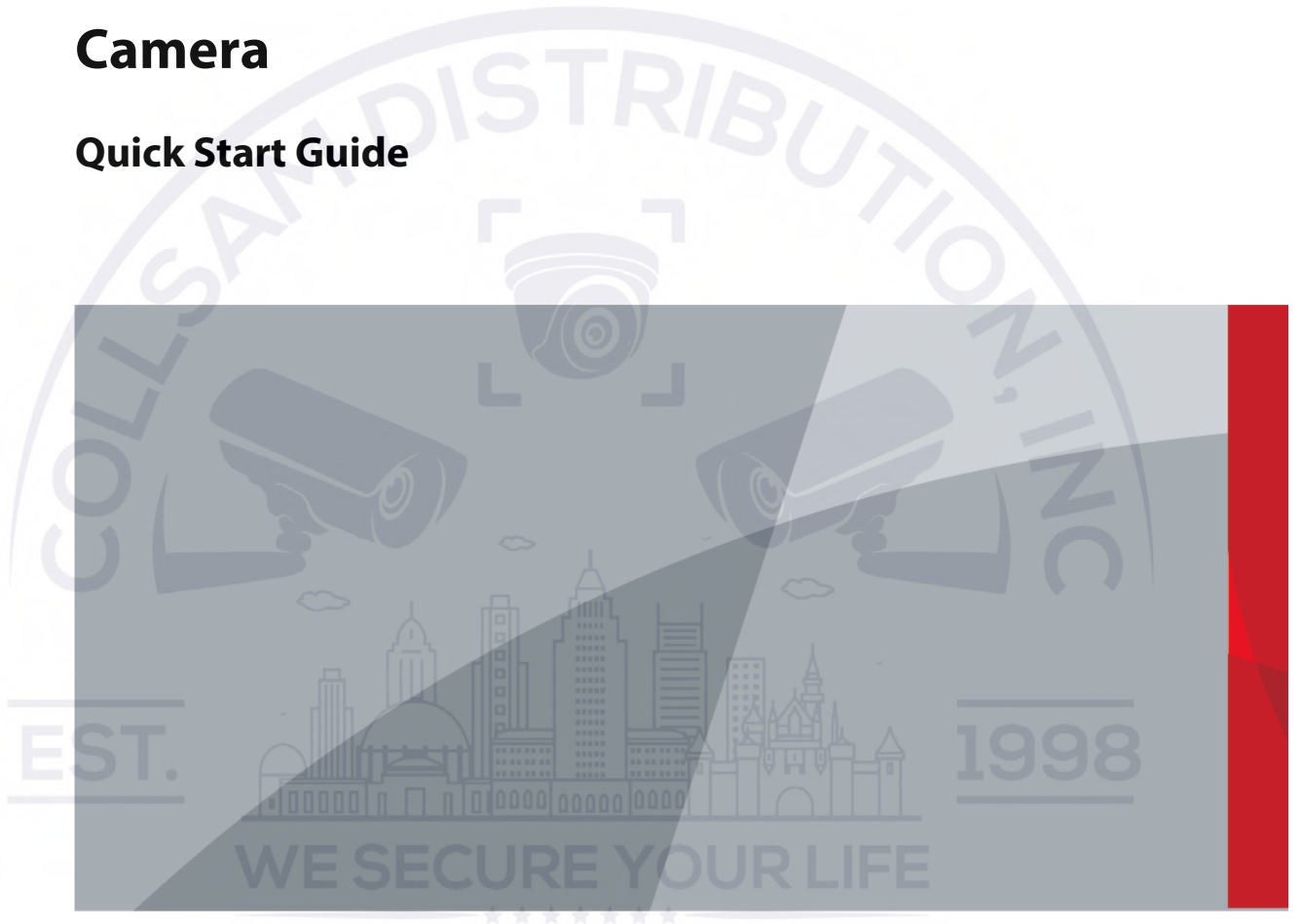

# Multi-Sensor Panoramic Network + PTZ Camera

## Quick Start Guide



ZHEJIANG DAHUA VISION TECHNOLOGY CO., LTD

V1.0.1



# Foreword

## General

This manual introduces the functions and operations of the camera.

## Safety Instructions

The following categorized signal words with defined meaning might appear in the manual.

Signal Words	Meaning
 <b>WARNING</b>	Indicates a medium or low potential hazard which, if not avoided, could result in slight or moderate injury.
 <b>CAUTION</b>	Indicates a potential risk which, if not avoided, could result in property damage, data loss, lower performance, or unpredictable result.
 <b>NOTE</b>	Provides additional information as the emphasis and supplement to the text.

## Revision History

Version	Revision Content	Release Date
V1.0.1	Updated "Important Safeguards and Warnings".	April 2021
V1.0.0	First release.	July 2020

## About the Manual

- The manual is for reference only. If there is inconsistency between the manual and the actual product, the actual product shall prevail.
- We are not liable for any loss caused by the operations that do not comply with the manual.
- The manual would be updated according to the latest laws and regulations of related jurisdictions. For detailed information, refer to the paper manual, CD-ROM, QR code or our official website. If there is inconsistency between paper manual and the electronic version, the electronic version shall prevail.
- All the designs and software are subject to change without prior written notice. The product updates might cause some differences between the actual product and the manual. Please contact the customer service for the latest program and supplementary documentation.
- There still might be deviation in technical data, functions and operations description, or errors in print. If there is any doubt or dispute, we reserve the right of final explanation.
- Upgrade the reader software or try other mainstream reader software if the manual (in PDF format) cannot be opened.
- All trademarks, registered trademarks and the company names in the manual are the properties of their respective owners.
- Please visit our website, contact the supplier or customer service if there is any problem occurring when using the device.
- If there is any uncertainty or controversy, we reserve the right of final explanation.

# Important Safeguards and Warnings

## Electrical Safety

- All installation and operation shall conform to your local electrical safety codes.
- The power source shall conform to the Safety Extra Low Voltage (SELV) standard, and supply power with rated voltage which conforms to Limited Power Source requirement according to IEC60950-1. Note that the power supply requirement is subject to the device label.
- Make sure that the power supply is correct before operating the device.
- A readily accessible disconnecting device shall be incorporated in the building installation wiring.
- Prevent the power cable from being trampled or pressed, especially the plug, power socket and the junction extruded from the device.

## Environment

- Do not aim the device at strong light to focus, such as lamp light and sun light; otherwise it might cause over brightness or light marks, which are not the device malfunction, and affect the longevity of Complementary Metal-Oxide Semiconductor (CMOS).
- Do not place the device in a damp, dusty extremely hot or cold environment, or the locations with strong electromagnetic radiation or unstable lighting.
- Keep the device away from any liquid to avoid damage to the internal components.
- Keep the indoor device away from rain or damp to avoid fire or lightning.
- Keep sound ventilation to avoid heat accumulation.
- Transport, use and store the device within the range of allowed humidity and temperature.
- Heavy stress, violent vibration or water splash are not allowed during transportation, storage and installation.
- Pack the device with standard factory packaging or the equivalent material when transporting the device.
- Install the device in the location where only the professional staff with relevant knowledge of safety guards and warnings can access. The accidental injury might happen to the non-professionals who enter the installation area when the device is operating normally.

## Operation and Daily Maintenance

- Do not touch the heat dissipation component of the device to avoid scald.
- Carefully follow the instructions in the manual when performing any disassembly operation about the device; otherwise, it might cause water leakage or poor image quality due to unprofessional disassembly. Please make sure that the gasket ring is flat and properly installed in the groove before installing the cover. Please contact after-sale service for desiccant replacement if there is condensed fog on the lens after unpacking or when the desiccant turns green (Not all models are included with the desiccant).
- It is recommended to use the device together with lightning arrester to improve lightning protection effect.
- It is recommended to ground the device to enhance reliability.
- Do not touch the image sensor (CMOS) directly. Dust and dirt could be removed with air blower, or you can wipe the lens gently with soft cloth that is moistened with alcohol.

- You can clean the device body with soft dry cloth, and for stubborn stains, use the cloth with mild detergent. To avoid possible damage on device body coating which could cause performance decrease, do not use volatile solvent such as alcohol, benzene, diluent and so on to clean the device body, nor can strong, abrasive detergent be used.
- Dome cover is an optical component. Do not touch or wipe the cover with your hands directly during installation or operation. For removing dust, grease or fingerprints, wipe gently with moistened oil-free cotton with diethyl or moisten soft cloth. You can also remove dust with an air blower.

 **WARNING**

- Strengthen the protection of network, device data and personal information by adopting measures which include but not limited to using strong password, modifying password regularly, upgrading firmware to the latest version, and isolating computer network. For some device with old firmware versions, the ONVIF password will not be modified automatically along with the modification of the system password, and you need to upgrade the firmware or manually update the ONVIF password.
- Use standard components or accessories provided by manufacturer and make sure that the device is installed and maintained by professional engineers.
- The surface of the image sensor should not be exposed to laser beam radiation in an environment where a laser beam device is used.
- Do not provide two or more power supply sources for the device unless otherwise specified. A failure to follow this instruction might cause damage to the device.



# Table of Contents

Foreword .....	I
Important Safeguards and Warnings .....	II
1 Introduction .....	1
2 Cable .....	2
3 Network Configuration .....	4
3.1 Initializing Device .....	4
3.2 Modifying Device IP Address .....	6
3.3 Logging in to Web Interface .....	6
4 Smart Track Configuration .....	8
4.1 Enabling Alarm Track .....	8
4.2 Configuring calibration parameter .....	8
5 Installation .....	11
5.1 Packing List .....	11
5.2 Dimensions .....	11
5.3 Installing Camera .....	12
5.3.1 Installation Method .....	12
5.3.2 Installing SD Card (Optional) .....	12
5.3.3 Attaching Camera .....	13
5.3.4 Installing Waterproof Connector (Optional) .....	15
5.3.5 Adjusting Lens Angle .....	15



# 1 Introduction

This series product is a type of integrated camera which consists of panoramic camera and tracking PTZ camera. It provides monitoring effect of both panoramic and partial details. Panoramic camera can provide real-time HD surveillance of 180°/270°/360° view coverage. Besides, it is convenient to recognize and exclude abnormality via quick positioning and zoom in of tracking PTZ camera when abnormality happens.

The cameras are applicable to cover the high definition panoramic monitoring needs, such as public security, traffic, building, museum, hospital, school, and more.



## 2 Cable



- Cable type might vary with different devices, and the actual product shall prevail.
- Waterproof all the cable joints with insulating tape and waterproof tape to avoid short circuit and water damage. For the detailed operation, see the *FAQ Manual*.

Figure 2-1 Cables

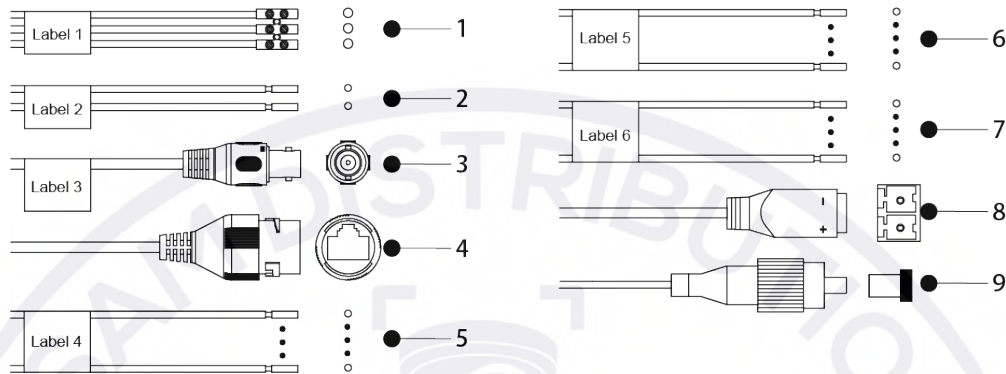

For more information about cable ports, see Table 2-1.

Table 2-1 Cable information



No.	Port name	Description
1	Power input	<ul style="list-style-type: none"> <li>• Red: 36V DC power input.</li> <li>• Black: Ground connection.</li> <li>• Yellow and green: Ground connection.</li> </ul> Device abnormality or damage could occur if power is not supplied correctly.
2	RS-485 port	Reserved port.
3	Video output	BNC port. Connects to TV monitor to check image when outputting analog video signal.
4	Ethernet port	Connects to network with network cable.
5	Audio	Includes audio input and output ports. For detailed information, see Table 2-2.
6	I/O	Includes alarm signal input and output ports, the number of I/O ports might vary on different devices. For detailed information, see Table 2-3.
7		
8	12V DC power output	Supplies 12V DC (2W) power for external devices.
9	OPT	Connects to network with optical fiber.

Table 2-2 Audio I/O

Port	Port Name	Description
Audio	AUDIO_OUT 1	Connects to speaker to output audio signal.
	AUDIO_OUT 2	
	AUDIO_IN 1	Connects to sound-pick-up device to receive audio signal.
	AUDIO_IN 2	
	AUDIO_GND	Ground connection.

For more information about I/O port, see Table 2-3.

Table 2-3 Alarm information

Port	Port Name	Description
Alarm I/O	ALARM_OUT	Outputs alarm signal to alarm device.
	ALARM_COM	 When connecting to alarm device, only the ALARM_OUT port and ALARM_OUT_GND port with the same number can be used together.
	ALARM_IN	Receives the switch signal of external alarm source.
	ALARM_GND	 Connect different alarm input devices to the same ALARM_IN_GND port.



# 3 Network Configuration

Device initialization and IP setting can be finished with the "ConfigTool" or on web interface. For more information, see the *Web Operation Manual*.



- Device initialization is available on select models, and it is required at first-time use and after device is being reset.
- Device initialization is available only when the IP addresses of the device (192.168.1.108 by default) and the PC stays in the same network segment.
- Plan usable network segment properly to connect the device to the network.
- The following figures and interfaces are for reference only, and the actual product shall prevail.

## 3.1 Initializing Device

Step 1 Double-click "ConfigTool.exe" to open the tool.

Step 2 Click .

The **Modify IP** interface is displayed.

Figure 3-1 Modify IP

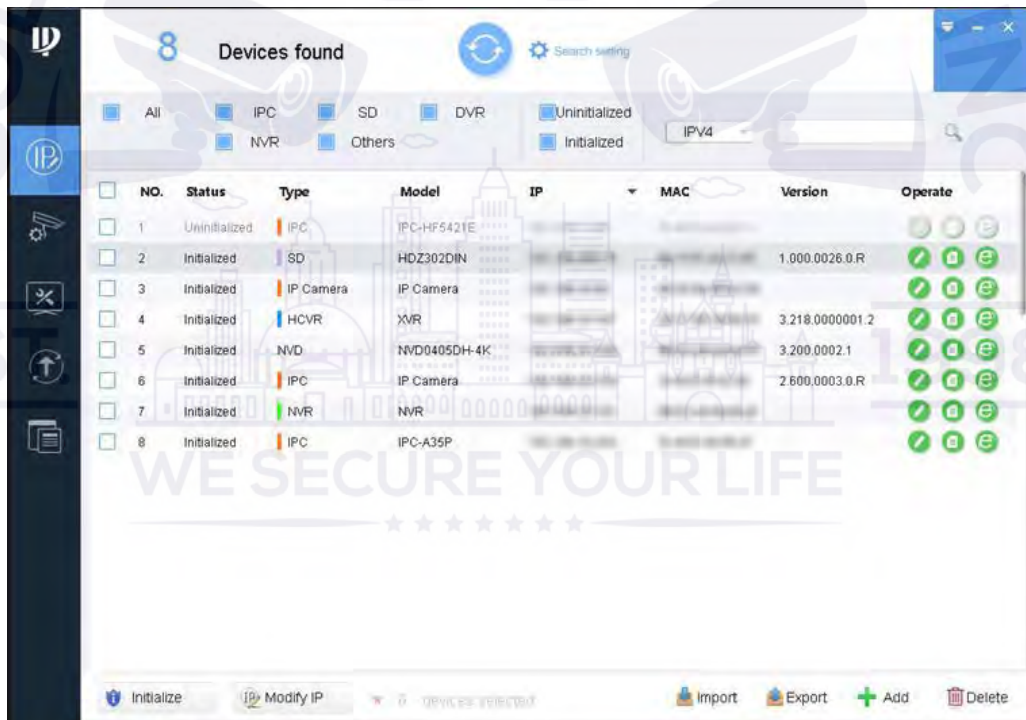

Step 3 Click **Search setting**.

The **Setting** interface is displayed.

Step 4 Enter the start IP address and end IP address of the network segment in which you want to search devices, and then click **OK**.

All the devices found in the network segment are listed.

- Step 5** Select one or several devices in uninitialized status, and then click **Initialize**.  
The **Device initialization** interface is displayed.
- Step 6** Select the devices that need initialization, and then click **Initialize**.  
The password setting interface is displayed.

Figure 3-2 Password setting

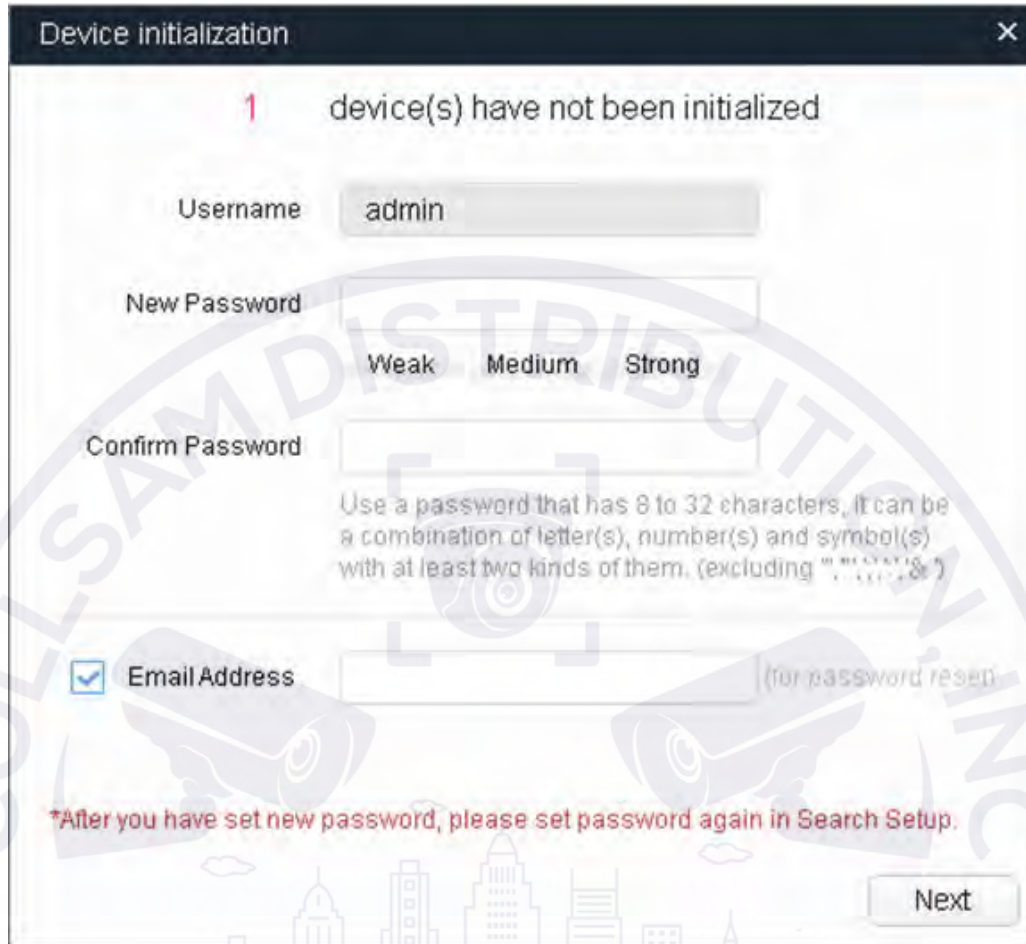

- Step 7** Set and confirm the password of the devices, then enter a valid email address, and then click **Next**.  
The final setting interface is displayed.



Password can be modified or reset in **System Settings**.

- Step 8** Select the options according to your needs, and then click **OK**.  
The **Initialization** interface is displayed after initialization is completed. Click the success icon (✓) or the failure icon (▲) for the details.
- Step 9** Click **Finish**.  
The device status on the **Modify IP** interface (Figure 3-1) turns to **Initialized**.

## 3.2 Modifying Device IP Address



- You can modify IP address of one or multiple devices at one time. This section is based on modifying IP addresses in batches.
- Modifying IP addresses in batches is available only when the corresponding devices have the same login password.

**Step 1** Do **Step 1** to **Step 4** in "3.1 Initializing Device" to search devices in your network segment.



After clicking **Search setting**, enter the username and password, and make sure that they are the same as what you set during initialization; otherwise there will be wrong password notice.

**Step 2** Select the devices whose IP addresses need to be modified, and then click **Modify IP**. The **Modify IP Address** interface is displayed.

Figure 3-3 Modify IP address

**Step 3** Select **Static** mode, and then enter start IP, subnet mask, and gateway.



- IP addresses of multiple devices will be set to the same if you select the **Same IP** check box.
- If DHCP server is available in the network, devices will automatically obtain IP addresses from DHCP server when you select **DHCP**.

**Step 4** Click **OK**.

## 3.3 Logging in to Web Interface

**Step 1** Open IE browser, enter the IP address of the device in the address bar, and then press Enter key.

If the setup wizard is displayed, finish the settings as instructed.

- Step 2 Enter the username and password in the login box, and then click **Login**.
- Step 3 For the first-time login, click **Click Here to Download Plugin**, and then install the plugin as instructed.

The main interface is displayed when the installation is finished.

Figure 3-4 Main interface



## 4 Smart Track Configuration

Enable smart track, and then configure the tracking parameters. And when any anomaly is detected, the speed dome would track the target until it gets out of the surveillance range.

### Prerequisites

You already configured heat map, intrusion, or tripwire on the panoramic camera.

### 4.1 Enabling Alarm Track

Alarm track is disabled by default; and you need to enable it manually.

**Step 1** Select **Setting > Event > Smart Track > Alarm Track**.

**Step 2** Click **On** to enable **Alarm Track**. For details, see *Web Operation Manual*.

Figure 4-1 Alarm track

### 4.2 Configuring calibration parameter

The camera is equipped with calibration parameter by default, and you can modify them manually as needed.



Auto calibration mode is available on some select models.

**Step 1** Select **Setting > Event > Smart Track > Smart Track**.

**Step 2** Configure calibration parameters.

- Auto calibration
  - Select **Auto** in **Calibration Mode**, and then click **Start Calibration**.

Figure 4-2 Auto calibration

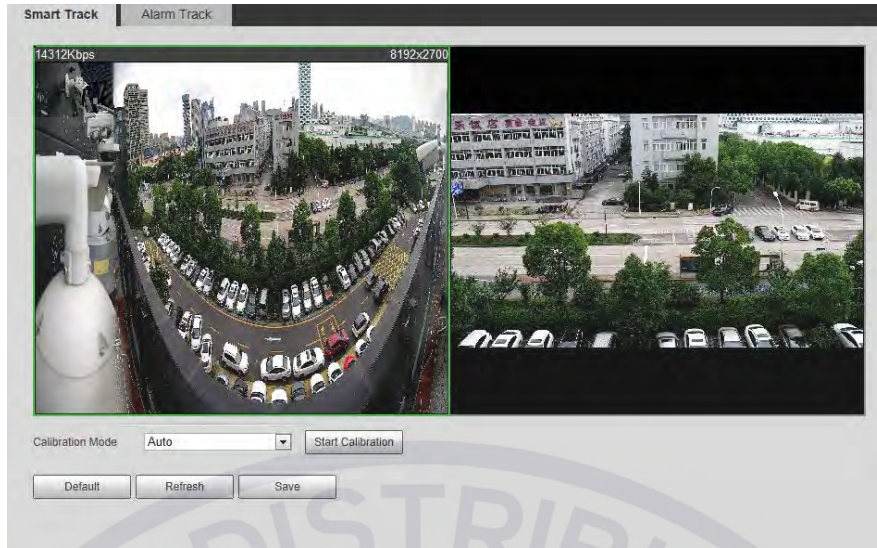

- Manual calibration  
Select **Manual** in **Calibration Mode**, select the lens that you need, and then add calibration point for it in the live image.



Interface might vary with different models, and the actual interface shall prevail.

Figure 4-3 Manual calibration (1)

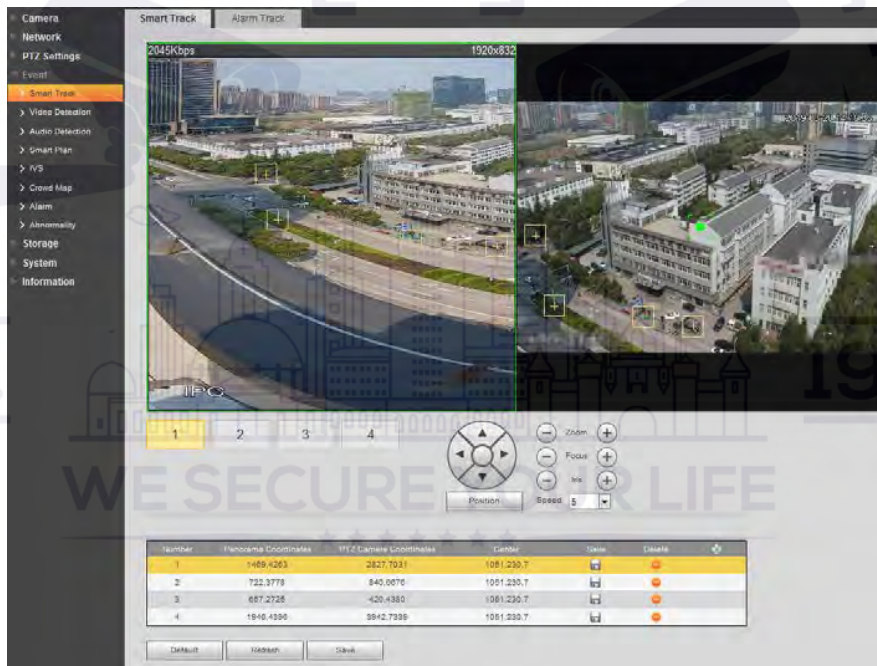
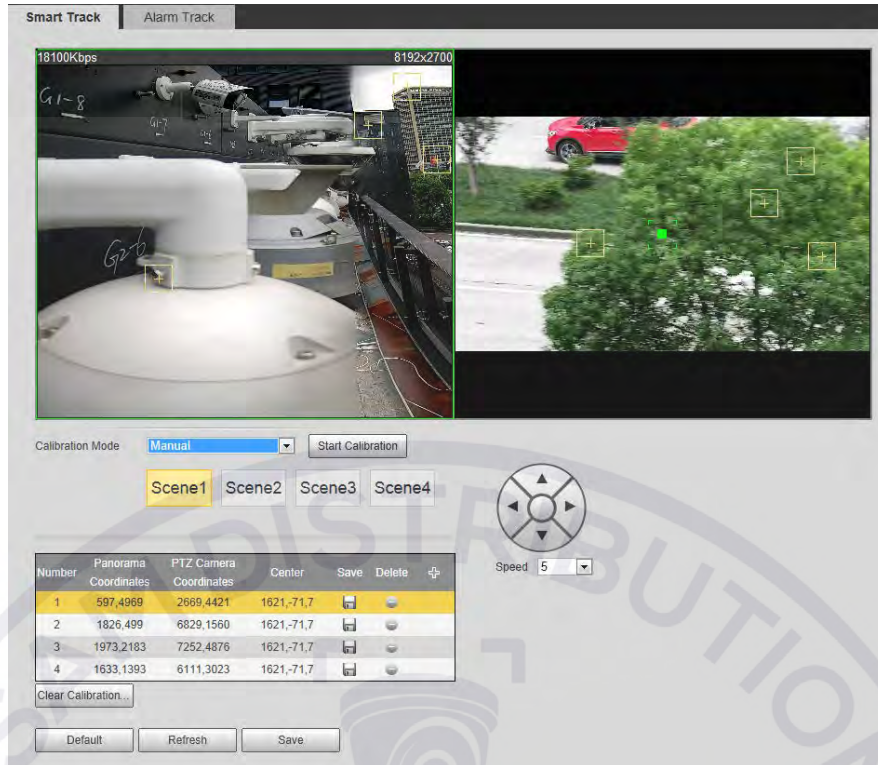

Figure 4-4 Manual calibration (2)



- 1) Adjust the speed dome lens and turn it to the same view as the chosen lens, and then click . The calibration boxes are displayed in both images.
- 2) Pair each box in the two images, and keep the paired boxes at the same spot of the live view.
- 3) Click . You need at least 4 pairs of calibration boxes to ensure the views of the speed dome and the panoramic camera as similar as possible.

**Step 3** Click **Save**.



# 5 Installation

## 5.1 Packing List



- The tool required for the installation such as electric drill is not provided in the package.
- The operation manual and related tool information are contained in the disk or the QR code, and the actual package shall prevail.

Figure 5-1 Packing list

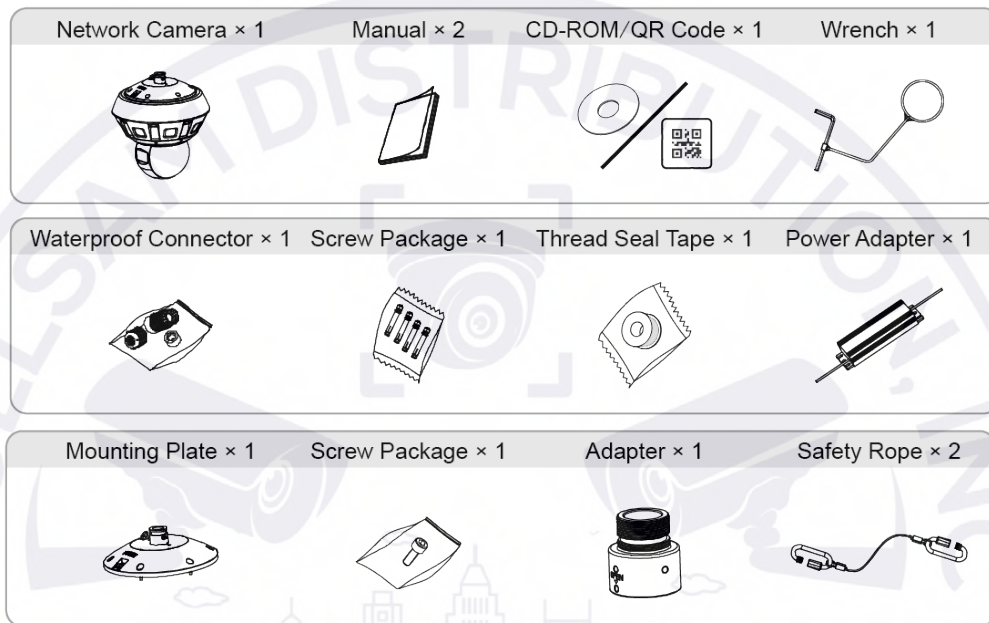

## 5.2 Dimensions



Following figures are for reference only, and the actual product shall prevail.

Figure 5-2 Dimensions (Unit: mm [inch])

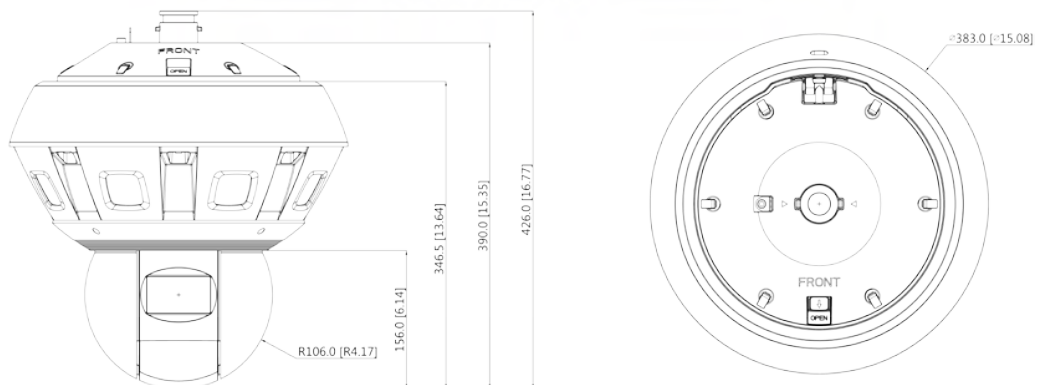

## 5.3 Installing Camera

### 5.3.1 Installation Method

Figure 5-3 Installation method

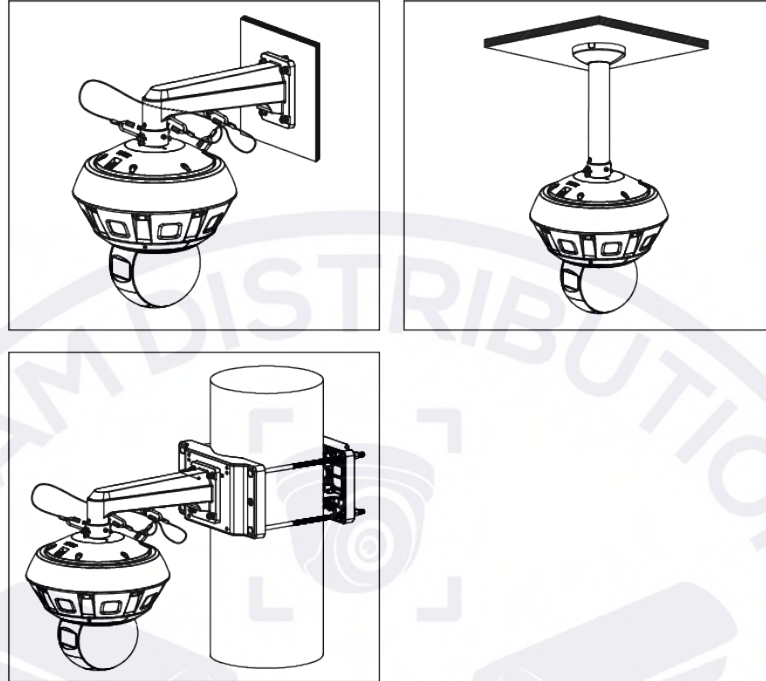

### 5.3.2 Installing SD Card (Optional)



- SD card slot is available on select models.
- Disconnect the power before installing or removing the SD card.

Figure 5-4 Installing SD card

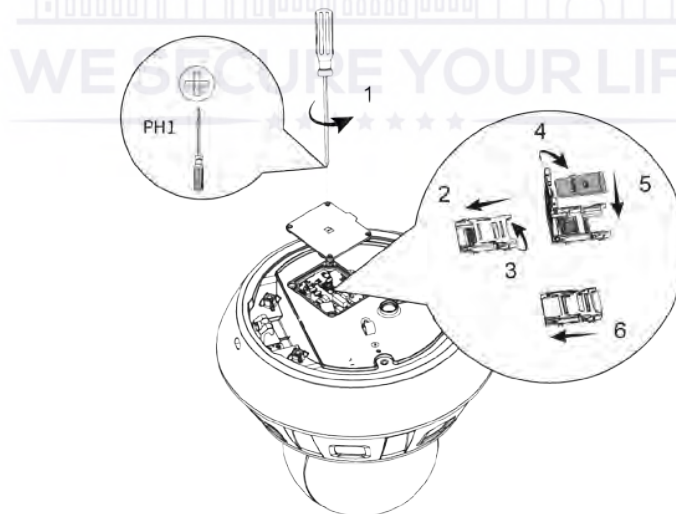

### 5.3.3 Attaching Camera



Make sure that the mounting surface is strong enough to hold at least three times of the weight of the device and bracket.



Figure 5-5 Cable going through the side cable tray

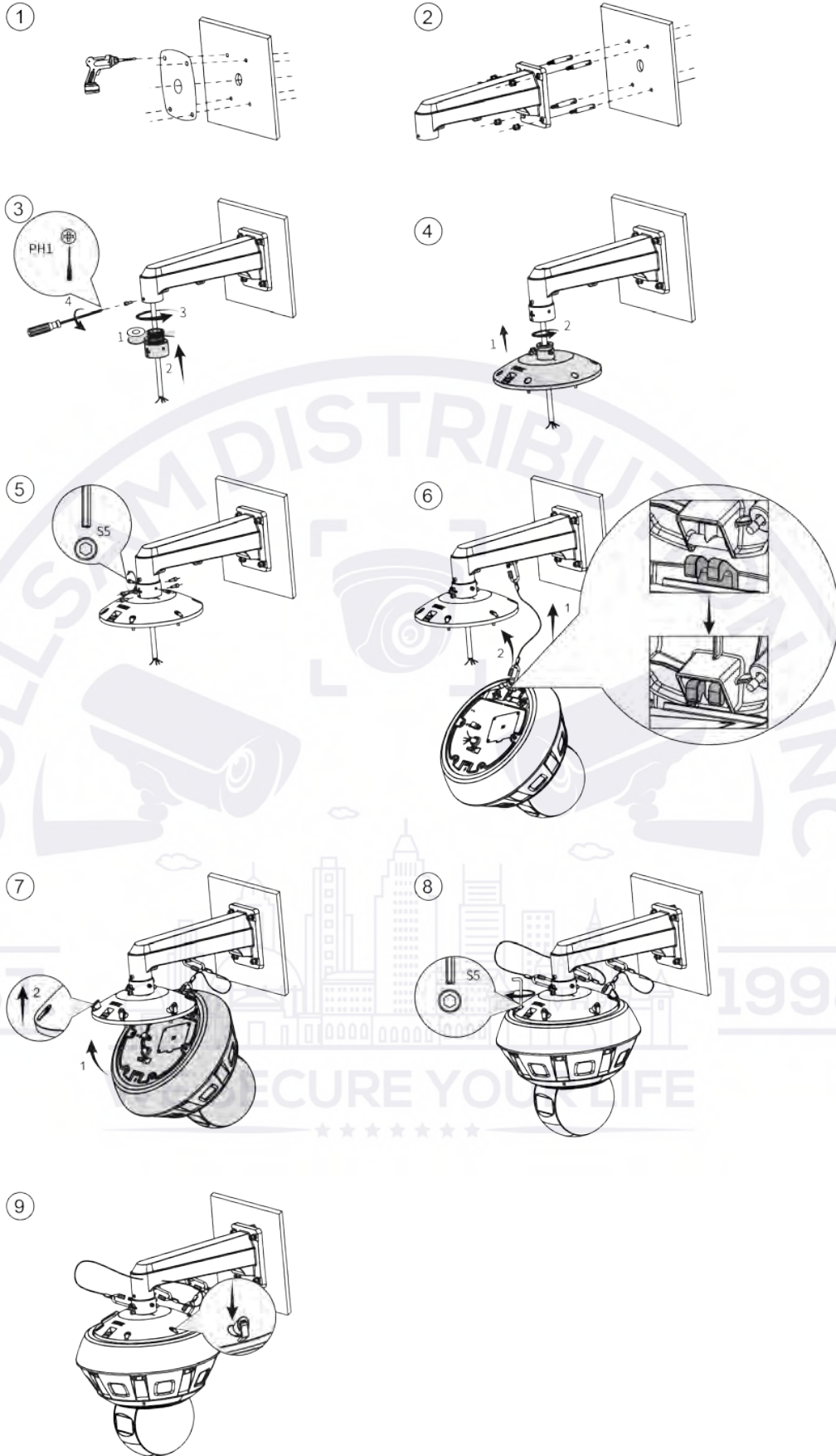

### 5.3.4 Installing Waterproof Connector (Optional)



This part is needed only when there is waterproof connector in the package and the device is used outdoors.

Figure 5-6 Installing waterproof connector

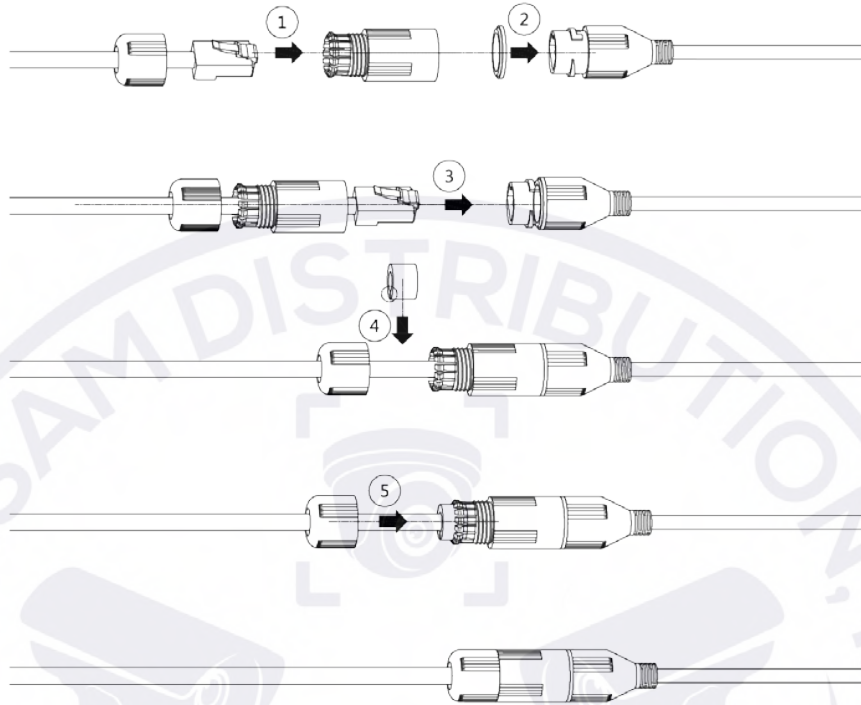

### 5.3.5 Adjusting Lens Angle

Figure 5-7 Adjusting lens angle

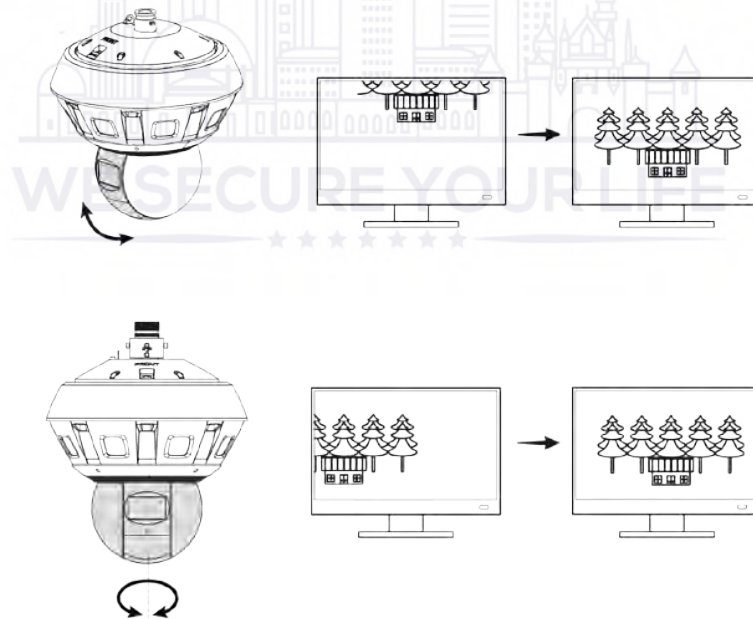



ENABLING A SAFER SOCIETY AND SMARTER LIVING

EST.

1998

WE SECURE YOUR LIFE



ZHEJIANG DAHUA VISION TECHNOLOGY CO., LTD.

Address: No. 1399, Binxing Road, Binjiang District, Hangzhou, P. R. China | Website: [www.dahuasecurity.com](http://www.dahuasecurity.com) | Postcode: 310053

Email: [dhoverseas@dhvisiontech.com](mailto:dhoverseas@dhvisiontech.com) | Tel: +86-571-87688888 28933188