



2MP 4x Mini PTZ Network Camera

Quick Start Guide

V1.0.2

EST.



1998

WE SECURE YOUR LIFE



Table of Contents

1	INSTALLATION PREPARATION.....	1
1.1	Basic Requirements.....	1
1.2	Installation Check.....	1
1.3	Cable Preparation.....	Error! Bookmark not defined.
1.3.1	Cable Lowest Specification Requirement.....	Error! Bookmark not defined.
1.3.2	Select Needed Power Supply Cable According to Transmission Distance	Error! Bookmark not defined.
2	SPEED DOME INSTALLATION.....	2
2.1	Check Accessories.....	2
2.2	Open Device.....	2
2.3	Installation Position Map.....	2
2.4	SD Card Slot and Rest Button.....	3
3	CAMERA INSTALLATION	4
3.1	Component Installation.....	4
3.2	Installation Steps	5
3.2.1	Installation Conditions	5
3.2.2	Installation Steps.....	5
4	APPENDIX I LIGHTENING PROTECTION AND SURGE PROTECTION	6

4.1 Outdoors 6

4.2 Indoors 7

5 APPENDIX II DC 12V WIRE GAUGE AND TRANSMISSION DISTANCE
RELATIONSHIP SHEET ERROR! BOOKMARK NOT DEFINED.

6 APPENDIX III WIRE GAUGE REFERENCE SHEET ERROR! BOOKMARK NOT
DEFINED.



Welcome

Thank you for purchasing our speed dome!

Please read the following safeguards and warnings carefully before you install or use the product!

- This manual is for reference only. Slight difference may be found in the user interface.
- All the designs and software here are subject to change without prior written notice.
- All trademarks and registered trademarks are the properties of their respective owners.
- If there is any uncertainty or controversy, please refer to the final explanation of us.
- Please visit our website or contact your local service engineer for more information.

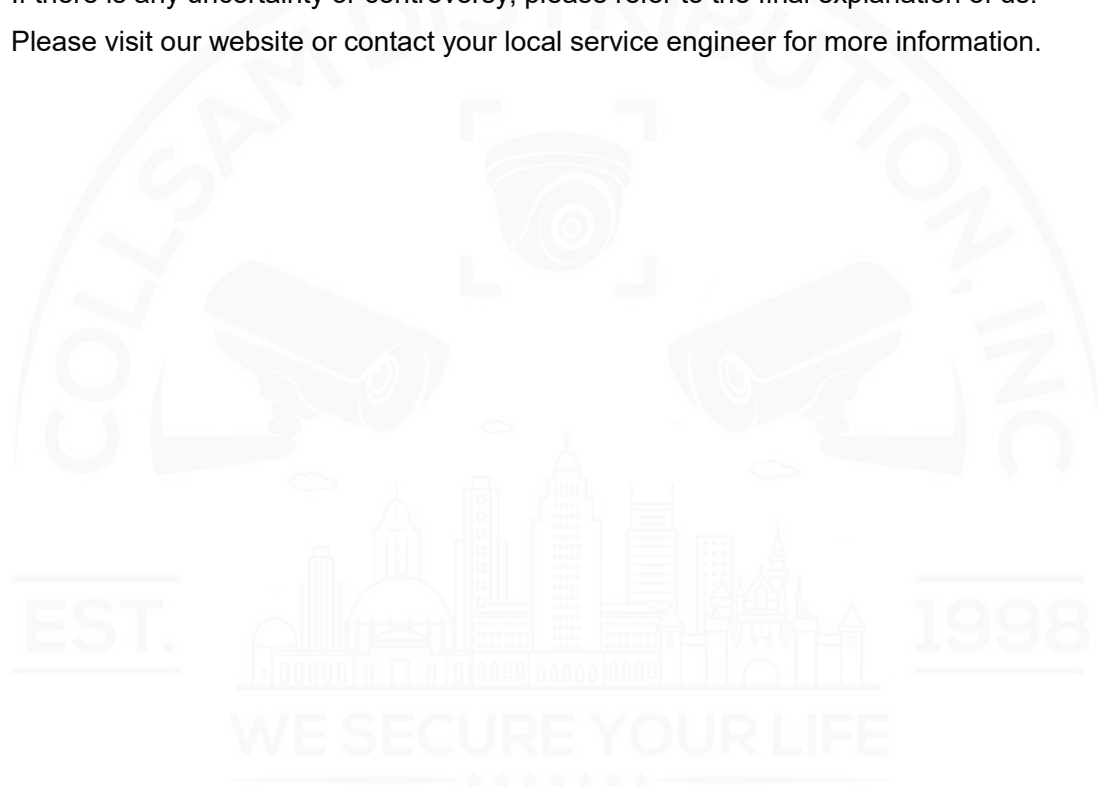

Important Safeguards and Warnings

Safety Measures

1. Qualified Engineer Needed

- The installation engineer or maintenance engineer shall have corresponding CCTV system installation certificate or maintenance qualification certificate.
- The installation engineer or maintenance engineer shall have qualification certificate for work at height.
- The installation engineer or maintenance engineer shall have the basic knowledge and operation technique for low-voltage cable layout and low-voltage electronic cable connection.
- Please read the installation manual carefully and keep it well for future reference,
- We are not liable for any problems caused by unauthorized modifications or attempted repair.

2. Lifting Appliance Requirement

- Please select the proper speed dome installation mode and use the lifting appliances at the safety environment.
- The lifting appliances shall have the enough capacity to reach the installation height.
- The lifting appliances shall have safe performance.

The precaution measures include two types: Warning and Note.

- **Warning:** It is to alert you there is an optional risk of death or series injury!
- **Note:** It is to alert you there is an optional risk of damage or property loss!

Warning

1. All installation and operation here should conform to your local electrical safety codes. We assume no liability or responsibility for all the fires or electrical shock caused by improper handling or installation.
2. Be sure to use all the accessories (such as power adapter) recommended by manufacturer.
3. Do not connect several speed domes to one power adapter. It may result in overheat or fire if it exceeds the rated load.
4. Avoid aiming the lens at the strong radiation source directly (such as sun, laser, molten steel etc); in case it may cause unrecoverable damage to the thermal imaging detector. What's worse, it may cause severe damage to the detector.
5. Avoid oil stain and kinds of chemicals tarnishing and damaging the lens surface.
6. Store the device in a cool and dry place where there is ventilation but no intense electromagnetic field.
7. Violent vibration or crash is not allowed during transportation and application.
8. Before you connect the cable, install or uninstall, or begin the daily maintenance work, please turn off the power and unplug the power cable.
9. Please make sure the produce is secure firmly on the wall or the ceiling.

10. Please turn off the power and unplug the power cable, If there is any smoke, disgusting smell, or noise. Please contact your local retailer or customer service centre for help.
11. All the examination and repair work should be done by the qualified service engineers. We are not liable for any problems caused by unauthorized modifications or attempted repair.

Note

1. Safety Transportation

- Heavy stress, violent vibration or water splash are not allowed during transportation, storage and installation.
- This series product must use split type package during the transportation.
- We are not liable for any damage or problem resulting from the integrated package during the transportation.

2. When device is malfunction

Shut down the device and disconnect the power cable immediately if there is smoke, abnormal smell or abnormal function. Please contact your local retailer ASAP.

3. Do not try to dismantle or modify the device

- There is risk of personal injury or device damage resulting from opening the shell.
- Please contact your local retailer if there is internal setup or maintenance requirement.
- We are not liable for any problems caused by unauthorized modifications or attempted repair.

4. Do not allow other object falling into the device

- Please make sure there is no metal or inflammable, explosive substance in the speed dome.
- The above mentioned objects in the device may result in fire, short-circuit or damage.
- Please shut down the device and disconnect the power cable if there is water or liquid falling into the camera. Please contact your local retailer ASAP.
- Please pay attention to the camera. Avoid the sea water or rain to erode the camera.

5. Handle carefully

Do not allow this series product fall down to the ground.

Avoid heavy vibration.

6. Installation Environment Requirement

- This series speed dome should be installed in a cool, dry place away from direct sunlight, inflammable, explosive substances and etc.
- This series product shall be away from the strong electromagnetism radiant, please keep it away from wireless power, TV transmitter, transformer and etc.

7. Daily Maintenance

- Please use the soft cloth to clean dust on the shell, or you can use soft cloth with cleaning liquid to clean the shell and then use soft cloth to make it dry.
- Do not use gasoline, dope thinner or other chemical material to clean the shell. It may result in shell transfiguration or paint flake.
- Do not allow the plastic or rubber material to touch the shell for a long time. It may result in paint flake.



1 Installation Preparation

1.1 Basic Requirements

- All installation and operation here should conform to your local electrical safety codes, fire protection regulations and relevant regulations.
- Make sure if the application scenarios of speed dome conforms to the installation requirements. Please contact your local retailer if you have any confusion.
- Please use the product according to the operating environment.
- Please keep the original packing material well after opening the package, which is used to pack speed dome and send it back for repair in case problems happen.

1.2 Installation Check

- Please make sure the installation environment has enough space to install the speed dome and its corresponding mounting components.
- Please make sure the ceiling and wall can sustain 8X weight of the speed dome and its mounting components.
- Please make sure the wall is thick enough to install expansion bolts (Users need to purchase expansion bolts separately).

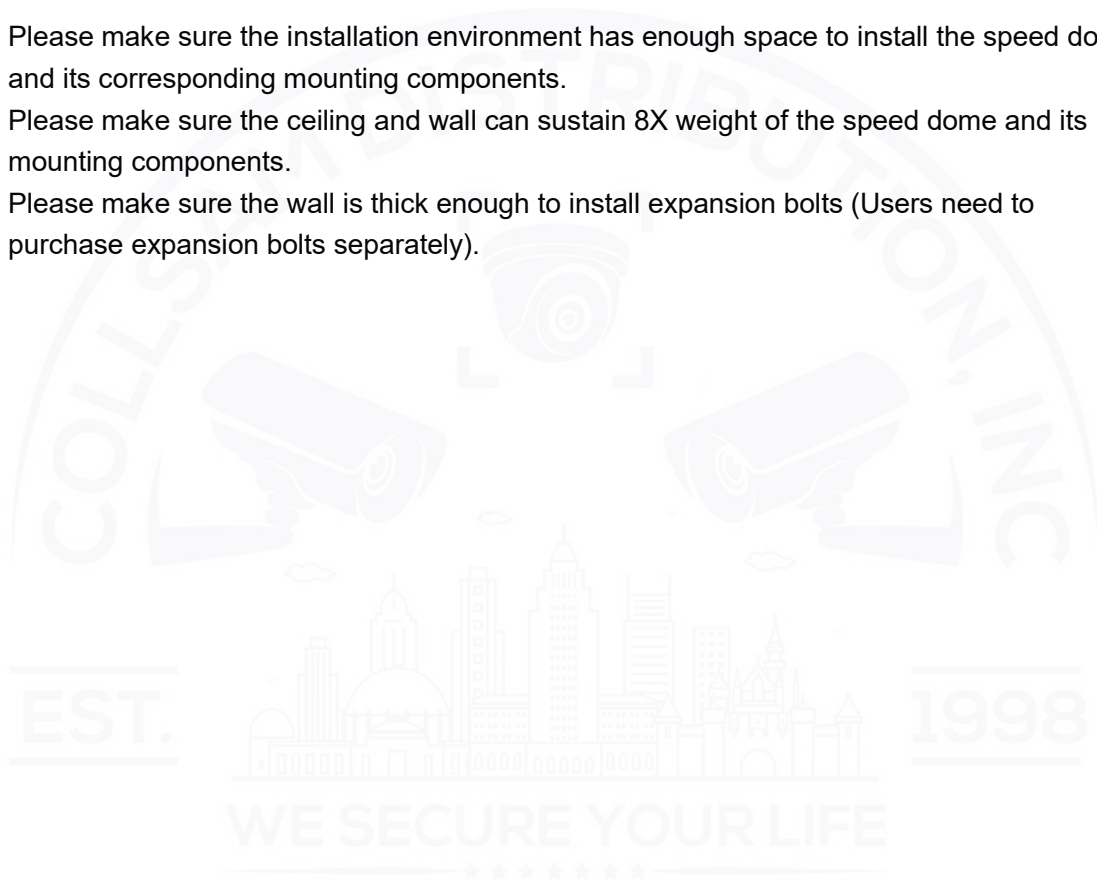

2 Speed Dome Installation

2.1 Check Accessories

Before installation, please check the accessories one by one according to the packing list. Please make sure all the components listed are included. (Please check the container list for details.)

2.2 Open Device

Remove the package and then take out the device. See Figure 2-1.

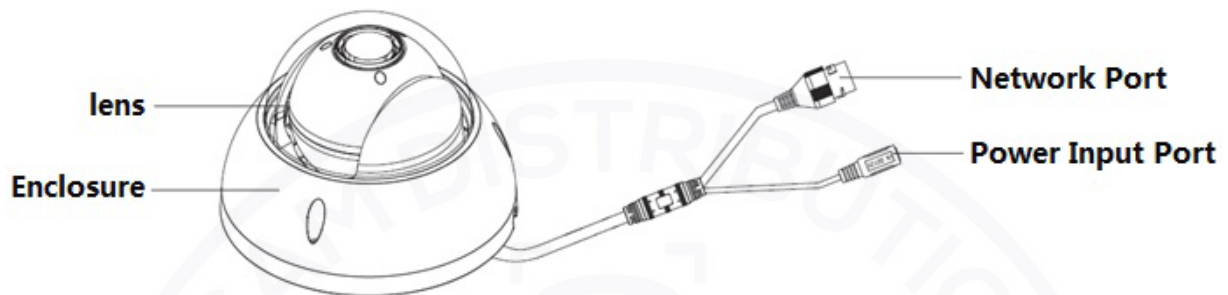

Figure 2-1

2.3 Installation Position Map

The installation position map is used for drilling positioning on the hard ceiling and cable exit position. Refer to Figure 2-2 for more details.

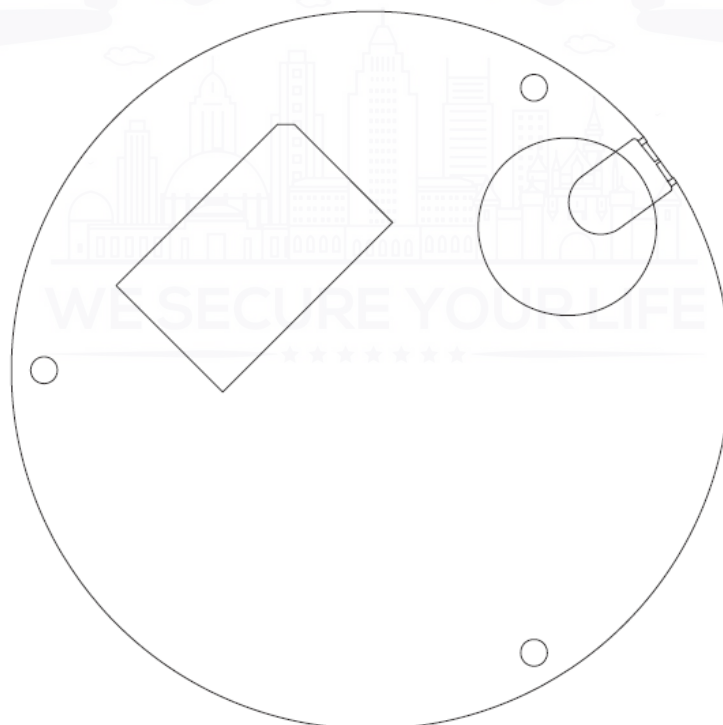

Figure 2-2

2.4 SD Card Slot and Rest Button

SD card slot and reset button are shown in Figure 2-3.

Please make sure the SD card is in the non read-write state when removing it. Otherwise, it may result in data loss and SD card damage. The button is used for default setting. Long press Reset button for more than 5 seconds, the system configuration information will be recovered to default setting.

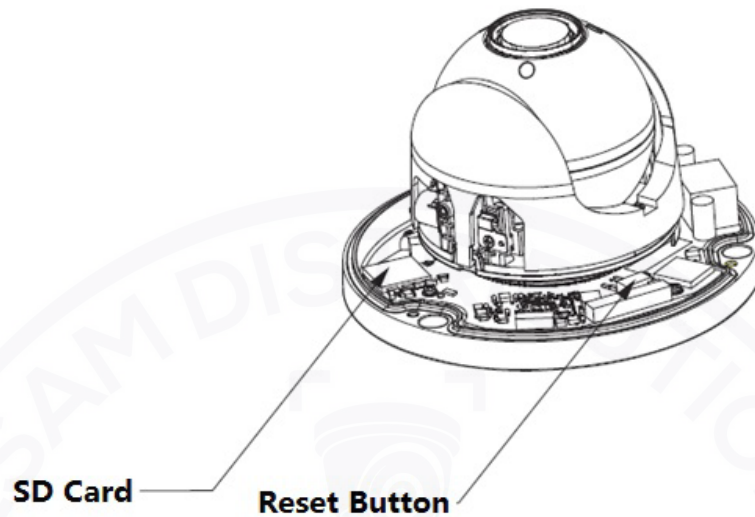
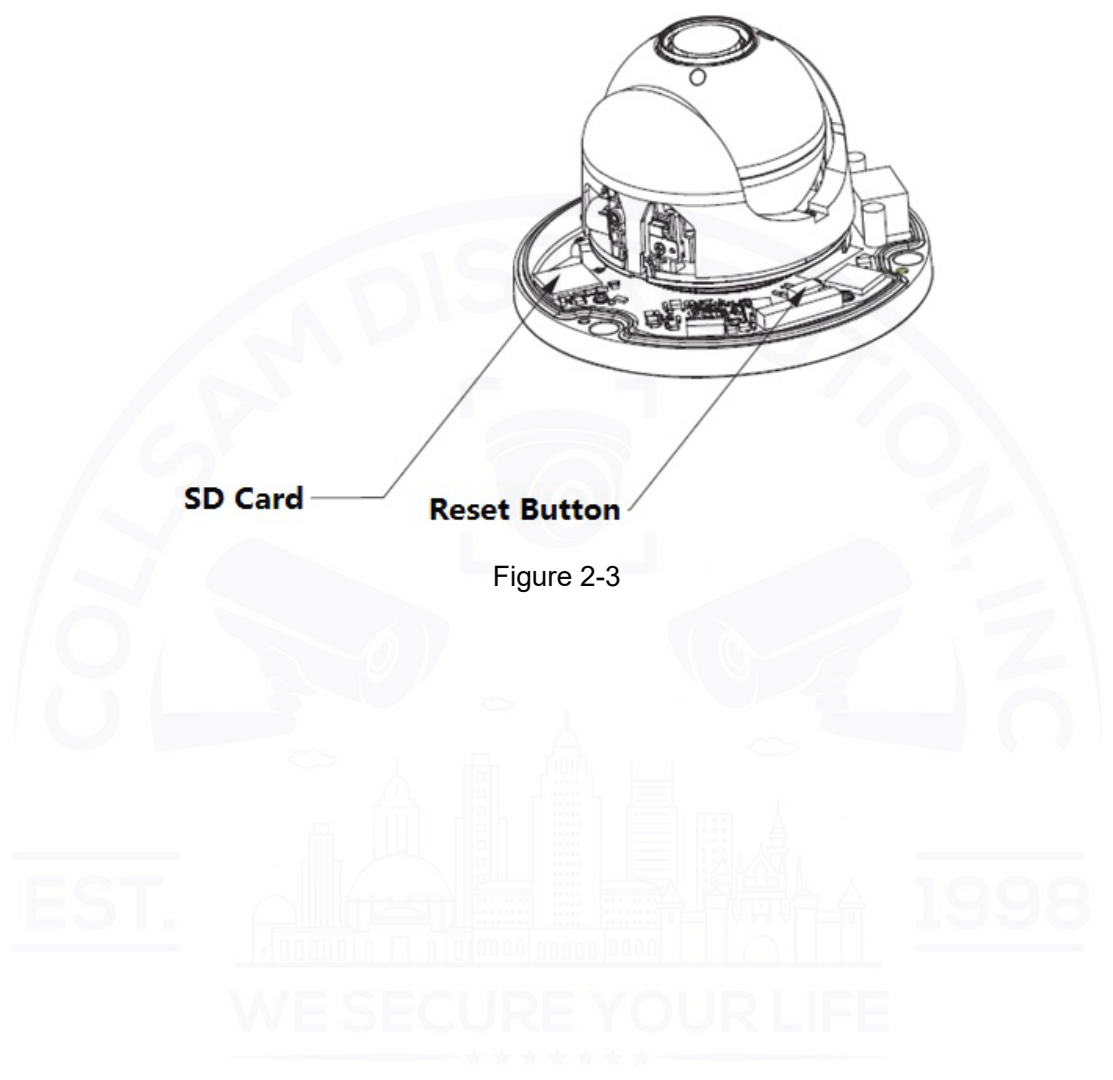

Figure 2-3



3 Camera Installation

2-inch network speed dome mainly adopts ceiling mount mode, which can be installed on the ceiling or wall.

3.1 Component Installation

The speed dome and its mounting component are shown in Figure 3-1.

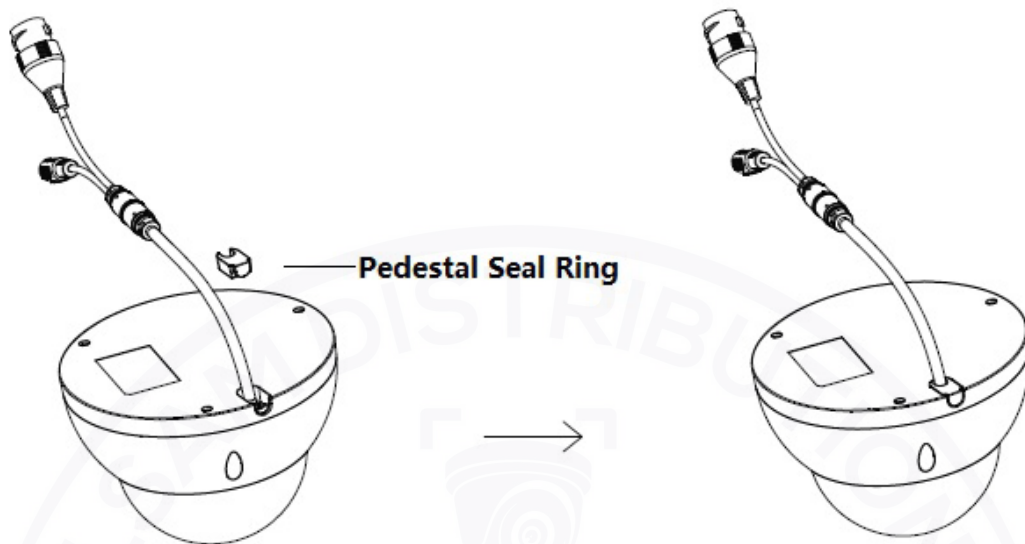

Figure 3-1

The ceiling-mounted speed dome is shown in Figure 3-2.

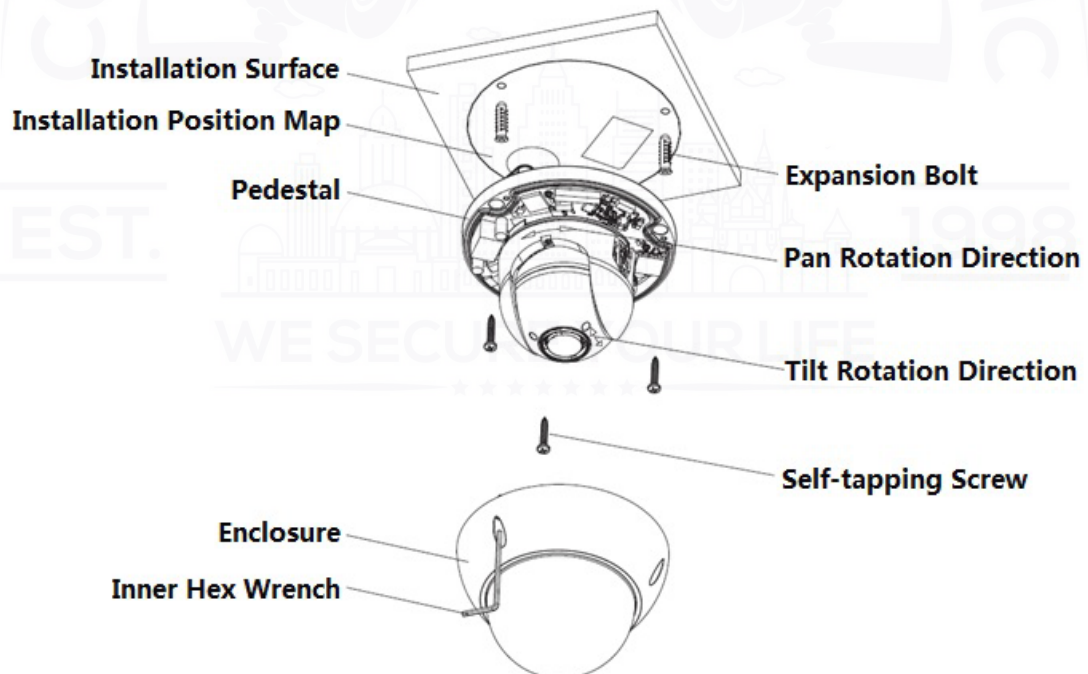

Figure 3-2

3.2 Installation Steps

3.2.1 Installation Conditions

The ceiling-mounted speed dome can be installed on the hard ceiling in the indoor environment.

The ceiling needs to satisfy the following installation conditions:

- The ceiling shall be thick enough to install the expansion bolt.
- The ceiling can sustain at least 8X weight of the speed dome and bracket.

3.2.2 Installation Steps

Note

There are two wiring modes for ceiling-mounted installation.

- It supports open wiring from side of the device if it fails to dig holes on the ceiling.
- It supports concealed wiring inside the ceiling if it digs holes on the ceiling.

Step 1

Install the default pedestal seal ring of the speed dome on the pedestal according to the method shown in Figure 3-1

Step 2

Confirm installation position and wiring mode first; mark punching position and dig holes on the ceiling according to the installation position map, and then insert three plastic expansion bolts into the holes you just dug.

Step 3

Use inner hex wrench to loosen three locking screws on the enclosure and then remove the enclosure.

Step 4

Lay the outgoing line well according to wiring mode, use three self-tapping screws to fix the pedestal on the mounting surface, insert the screws into the expansion bolts which have been pre-embedded.

Step 5

Adjust the lens direction to proper monitoring position according to the direction which is shown in Figure 3-2.

Step 6

Use three locking screws to fix the dome enclosure on the pedestal.

So far, the camera installation and cable connection have been completed, and you can adjust the lens angle, zoom and focus on the WEB interface.

4 APPENDIX I LIGHTENING PROTECTION AND SURGE PROTECTION

4.1 Outdoors

This series speed dome adopts TVS lightning protection technology. It can effectively prevent damages from various pulse signals below 6000V, such as sudden lightning and surge. While maintaining your local electrical safety code, you still need to take necessary precaution measures when installing the speed dome in the outdoor environment.

- The distance between the signal transmission cable and high-voltage device (or high-voltage cable) shall be at least 50 meters.
- Outdoor cable layout shall go under the penthouse if possible.
- For vast land, please use sealing steel tube under the land to implement cable layout and connects one point to the earth. Open floor cable layout is forbidden.
- In area of strong thunderstorm hit or near high sensitive voltage (such as near high-voltage transformer substation), you need to install additional high-power thunder protection device or lightning rod.
- The thunder protection and earth of the outdoor device and cable shall be considered in the building whole thunder protection and conform to your local national or industry standard.
- System shall adopt equal-potential wiring. The earth device shall meet anti-jamming and at the same time conforms to your local electrical safety code. The earth device shall not short circuit to N (neutral) line of high voltage power grid or mixed with other wires. When connect the system to the earth alone, the earth resistance shall not be more than $4\ \Omega$ and earth cable cross-sectional area shall be no less than $25\ \text{mm}^2$. See Figure 4-1.

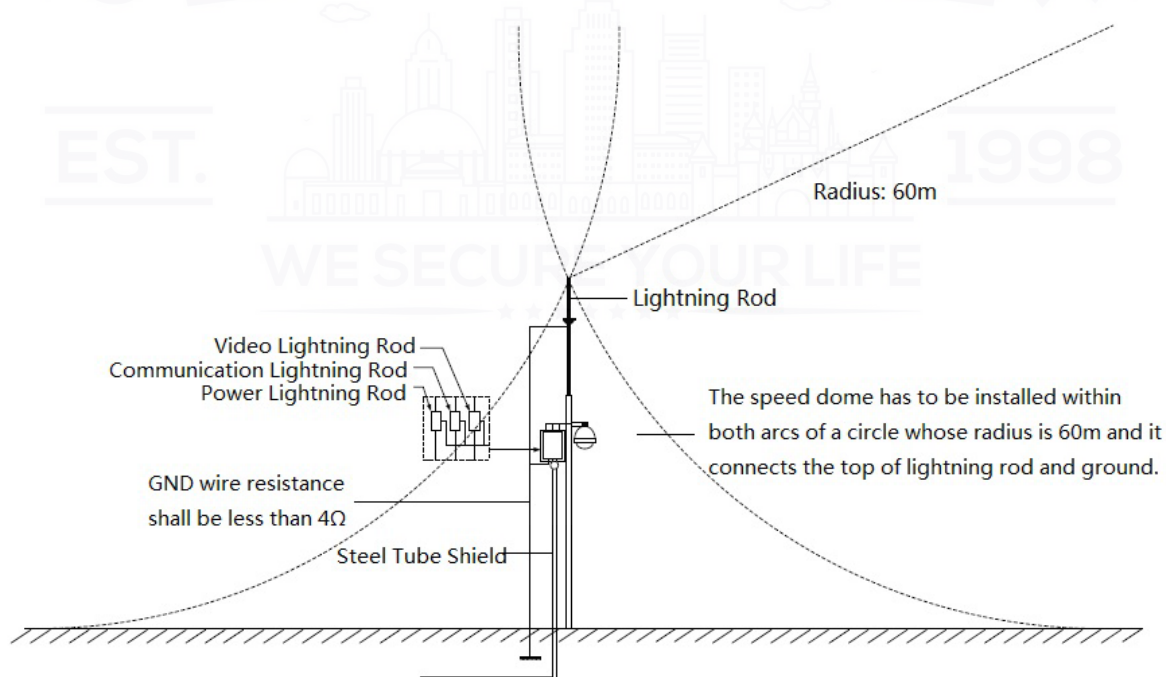

Figure 4-1

4.2 Indoors

The yellow and green GND wire or GND screw of the speed dome should be reliably connected by several strands of copper wire with no less than 25mm² and indoor equipotential GND terminal. Please refer to Figure 4-2 for lightning proof installation mode.

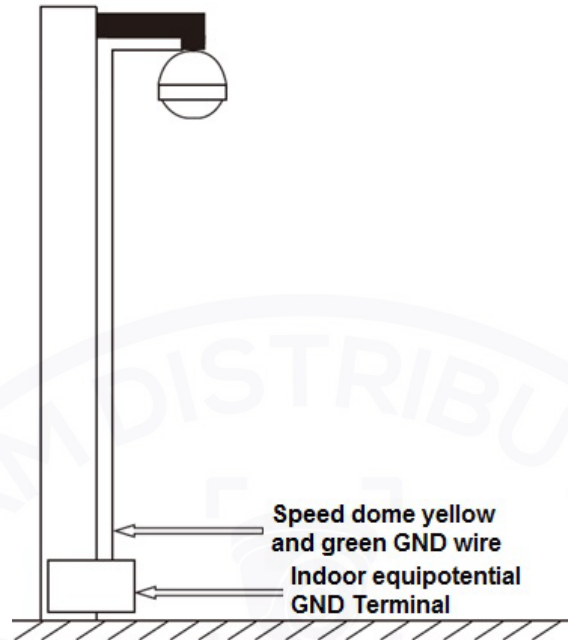

Figure 4-2

