

### Quick Start Guide

(A16381M7H6\_C)

Illustra Flex Gen4 2MP and 4MP Indoor and Outdoor PTZ cameras  
(P/N's IFS02-P07-OIA4, IFS02-P07-IIA4, IFS02-P07-ATA4 and IFS04-P07-OIA4, IFS04-P07-IIA4, IFS04-P07-ATA4)

#### In the box

- 1 x Network PTZ Camera
- 1 x Printed Quick Start Guide
- 1 x Printed Regulatory document
- 1 x NTSC/PAL output female BNC cable
- 1 x Torx 20 Security L-Key
- 1 x Torx 10 Security L-Key
- 1 x 12-pin terminal connector for I/O function
- 1 x 2-pin European style terminal block
- 3 x ¼ 20 UNC security screws
- 1 x mount adaptor
- 1 x Safety cable (pre-attached to the camera)

#### Installation tools

- 1 x Screwdriver
- 1 x Drill
- 1 x Wire cutters



Figure 1: Pictorial Index of the camera (IFS02-P07-IIA4 / IFS02-P07-OIA4 / IFS04-P07-IIA4 / IFS04-P07-OIA4)

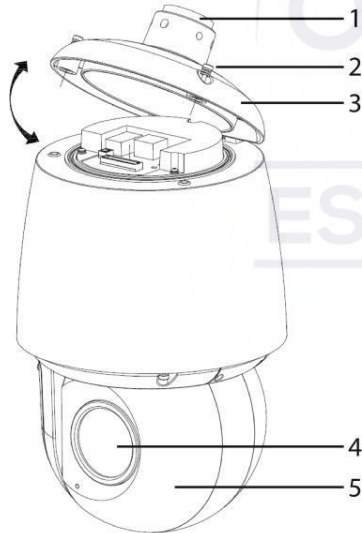

Figure 1

Table 1: Pictorial index descriptions

Button / connections	Description
1	NPT Pendant Cap
2	Screws (x2) to open and lock the top cover
3	Top cover
4	Camera lens
5	Camera head

#### Quick reference

- Default IP: 192.168.1.168 (DHCP enabled)
- Default Username / Password: admin / admin
- Power: Indoor PTZ = 24Vac / 48Vdc / IEEE 802.3at Type 2 (PoE+) and Outdoor PTZ = 24Vac / 48Vdc IEEE 802.3bt Type 4 (PoE++)

**Note:** Before you power up the camera; please ensure that all packaging has been removed, including packaging located inside the bubble.

#### Removing the bubble from the camera (IFS02-P07-ATA4 / IFS04-P07-ATA4)

**Note:** This is only applicable to specific indoor units with bubble.

1. Remove the three screws located on the camera head (1) (Figure 2).
2. Carefully remove the bubble unit (1) (Figure 3).

Removing the bubble from the camera (IFS02-P07-ATA4 / IFS04-P07-ATA4) (continued)

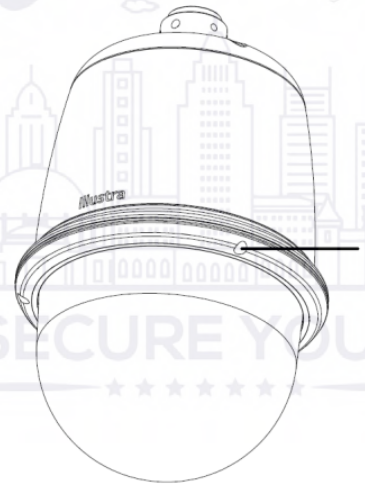

Figure 2

Removing the bubble from the camera (IFS02-P07-ATA4 / IFS04-P07-ATA4) (continued)

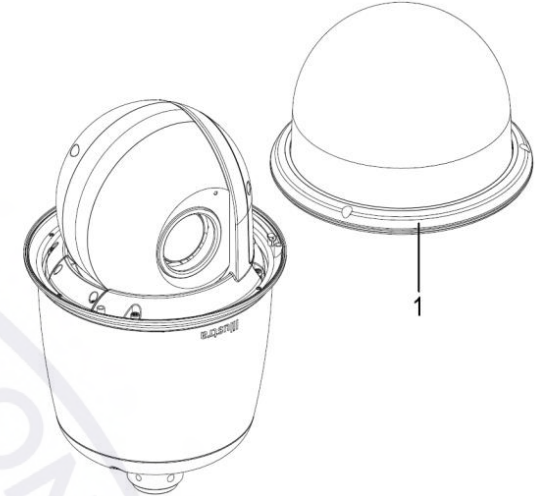

Figure 3

#### Accessing the connector pins

1. Remove the two screws located on the top cover (1) (Figure 4) to open it.

#### Accessing the connector pins (continued)

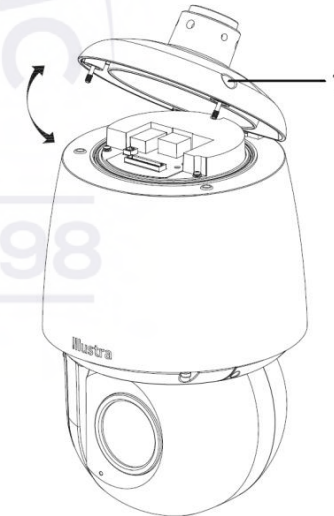
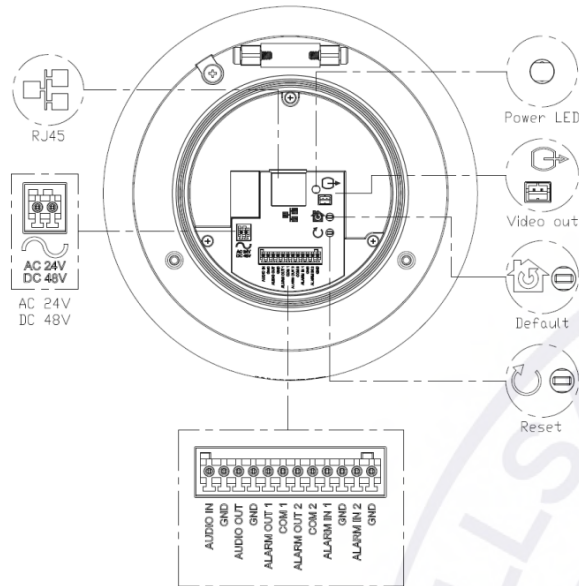

Figure 4

**Figure 5: Location of descriptions of the buttons / connections**



**Figure 5**

**Installing the rubber cable seal into the NPT pendant cap**

1. Securely place the rubber cable seal (1) (Figure 6) into the NPT pendant cap (2) (Figure 6).

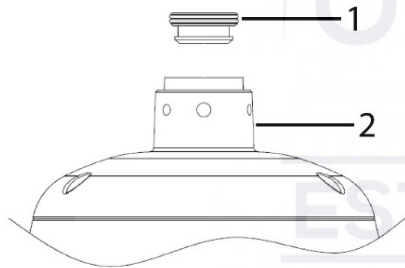

**Figure 6**

**Connecting the wires**

This unit supports one of the following options as power supply:

1. Connect a power source.
  - AC24V or DC48V wired to the connector and separate RJ45 Ethernet. And / Or
  - PoE through RJ45 connector.
    - o Indoor units operate with IEEE 802.3at Type 2 (PoE+)
    - o Outdoor units operate with IEEE 802.3bt Type 4 (PoE++)
2. Connect any optional audio or digital inputs or outputs.

**Note:** After connecting all cables ensure that the two screws on the top cover are securely attached.

**Inserting or removing the micro-SD card**

**Note:** For PTZ units that include a bubble you must remove the bubble before accessing the micro-SD card slot.

1. Remove the two screws located on the micro-SD card cover (1) (Figure 7).
2. Carefully pull open the cover to insert (or remove) the micro-SD card into (or from) the camera.

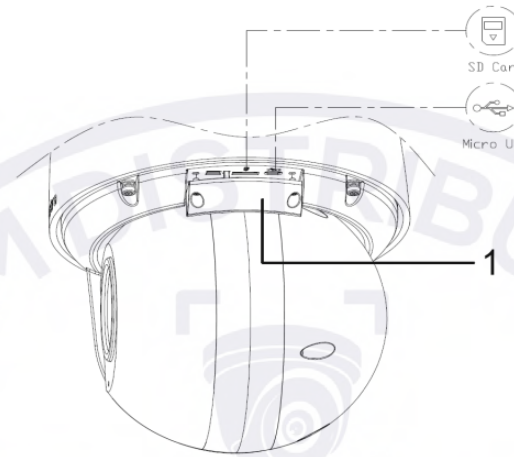

**Figure 7**

**Note:** The SD card slot and Micro USB port connection are now visible.

**Note:** It is advised that you reboot the camera after inserting the micro-SD card.

3. Secure the two screws (1) (Figure 7) located on the micro-SD card cover.

**Installing the mount adaptor on to the NPT pendant cap**

1. Place the mount adaptor (1) (Figure 8) on to the NPT pendant cap (2) (Figure 8) and align the holes on the mount adaptor with the holes on the NPT pendant cap.
2. Insert the five threaded screws into the five holes and use the Torx security L-Key to securely attach the screws and the mount adaptor to the NPT cap.

**Note:** To maintain the waterproof seal only pierce holes that are required for the installation.

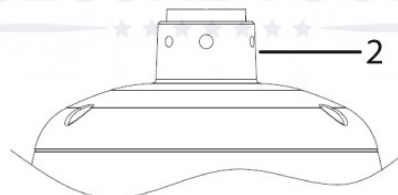
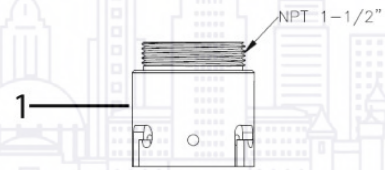

**Figure 8**

**Note**

- Johnson Control recommends connecting the device to a network that uses Dynamic Host Configuration Protocol (DHCP) server to address devices.
- To ensure secure access, place the device behind a firewall when it is connected to a network.
- The product is intended to be supplied by a Listed Power Unit marked "L.P.S." (or "Limited Power Source") and rated output: 24Vac, 50/60Hz, 3.8A, 48Vdc, 1.008A or PoE BT (56V), 0.92A
- The product shall be installed by a qualified service person and the installation shall conform to all local codes.
- If a Class I adapter or switch is used to provided power, be sure that the power cord is firmly plugged into the socket and confirm the main earth connection.

**Warnings**

1. **Note: Before you power up the camera; please ensure that all packaging has been removed, including packaging located inside the bubble assembly.**
2. Installation and service should be performed only by qualified and experienced technicians and comply with all local codes and rules to maintain your warranty.
3. Wipe the camera with a dry soft cloth. For tough stains, slightly apply with diluted neutral detergent and wipe with a dry soft cloth.
4. Do not apply benzene or thinner to the camera, which may cause the surface of the unit to be melted or lens to be fogged.
5. To meet EU EMC immunity requirements for security equipment the mains power for equipment powering this unit should be backed up by an uninterruptible power supply.
  - Indoor PTZ = 24Vac / 48Vdc / IEEE 802.3at Type 2 (PoE+)
  - Outdoor PTZ = 24Vac / 48Vdc IEEE 802.3bt Type 4 (PoE++)
6. Avoid operating or storing the unit in the following locations:
  - i. Near fluorescent lamps or objects with reflections.
  - ii. Under unstable or flickering light sources.

© 2022 Johnson Controls. All rights reserved. JOHNSON CONTROLS, TYCO and ILLUSTRATA are trademarks and/or registered trademarks. Unauthorized use is strictly prohibited.