

## Quick Guide

### Roughneck AI V2000D Series

**AI ANALYTICS INSIDE**

Outdoor Vandal Dome

Cameras



**Cybersecurity Notification:** All network connected devices should use best practices for accessing the device. To that end, these network cameras do not have a default password. A user defined password with minimum password strength requirements must be set to access the device. **See page 18** of this Quick Guide for set-up instructions.

Be sure to check Vicon's website to be see if you have the most up-to-date camera firmware.



## Table of Contents

<b>1</b>	<b>Product Overview</b>	<b>4</b>
1.1	Physical Characteristics	4
<b>2</b>	<b>Installation, Mounting and Connections</b>	<b>8</b>
2.1	Package Contents	8
2.2	Installation	8
2.2.1	Checking Appearance	8
2.2.2	Disassembling the Camera	9
2.2.3	Installing the Desiccant	10
2.2.4	Connecting the Cables	10
2.2.5	Mounting the Camera	12
2.2.6	Positioning the Camera	14
2.2.6	Reassembling the Camera	15
2.2.7	Lower Dome Defog	16
<b>3</b>	<b>Connection</b>	<b>17</b>
3.1	Network	17
3.2	System Requirements	17
3.3	Connecting Process	18
3.3.1	Accessing the Camera	18
3.3.2	Connecting from a Computer	18
3.4	PRONTO Device Manager	19



EST. 1998

**WE SECURE YOUR LIFE**

★ ★ ★ ★ ★ ★ ★

## WARNING

- This camera operates at 12 VDC/24 VAC/PoE (IEEE 802.3af Class 3).
- Installation and service should be performed only by qualified and experienced technicians and comply with all local codes and rules to maintain your warranty.
- We are NOT liable of any damage arising either directly or indirectly from inappropriate installation which is not depicted within this documentation.
- To reduce the risk of fire or electric shock, do not expose the product to rain or moisture.
- Wipe the camera with a dry soft cloth. For tough stains, slightly apply diluted neutral detergent and wipe with a dry soft cloth.
- Do not apply benzene or thinner to the camera, which may cause the surface to melt or lens fog.
- Avoid aligning the lens with extremely bright objects (e.g., light fixtures) for long periods of time.
- Although this camera is waterproof and suitable for both indoor and outdoor usages, please do not immerse the camera into water.
- Avoid operating or storing the camera in the following locations:
  - Extremely humid, dusty, or hot/cold environments (recommended operating temperature: -40°F to +140°F/-40°C to +60°C)
  - Close to sources of powerful radio or TV transmitters
  - Close to fluorescent lamps or objects with reflections
  - Under unstable or flickering light sources

	<p><b>CAUTION</b> RISK OF ELECTRIC SHOCK DO NOT OPEN</p>		<p>THIS SYMBOL INDICATES THAT DANGEROUS VOLTAGE CONSTITUTING A RISK OF ELECTRIC SHOCK IS PRESENT WITHIN THE UNIT.</p>
<p>CAUTION: TO REDUCE THE RISK OF ELECTRIC SHOCK, DO NOT REMOVE THE COVER. NO USER-SERVICEABLE PARTS INSIDE. REFER SERVICING TO QUALIFIED SERVICE PERSONNEL.</p>			<p>THIS SYMBOL INDICATES THAT IMPORTANT OPERATING AND MAINTENANCE INSTRUCTIONS ACCOMPANY THIS UNIT.</p>



**WEEE (Waste Electrical and Electronic Equipment).** Correct disposal of this product (applicable in the European Union and other European countries with separate collection systems). This product should be disposed of, at the end of its useful life, as per applicable local laws, regulations, and procedures.

## Get Started

This quick guide is designed as a reference for installation of the camera. For additional information on the camera's features, functions, and detailed explanation of the web interface controls, refer to User's Manual for details. Please read this quick guide thoroughly and save it for future use before attempting to install the camera. From this guide you will get:

- Product Overview: The physical parts, features and dimensions of the camera.
- Installation and Connection: The instructions on installation and wire connection for the camera.

## FCC Compliance Statement



Information to the user: This unit has been tested and found to comply with the limits for a Class B digital device pursuant to Part 15 of the FCC Rules. Operation is subject to the following two conditions: (1) this device may not cause harmful interference, and (2) this device must accept any interference received, including interference that may cause undesired operation. These limits are designed to provide reasonable protection against harmful interference in a residential installation. This unit generates, uses, and can radiate radio frequency energy and, if not installed and used in accordance with the manual, may cause harmful interference to radio communications. However, there is no guarantee that interference will not occur in a particular installation.

If this unit does cause harmful interference to radio or television reception, which can be determined by turning the unit off and on, the user is encouraged to try to correct the interference by one or more of the following measures:

- Reorient or relocate the receiving antenna.
- Increase the separation between the unit and receiver.
- Connect the unit to an outlet on a circuit different from that to which the receiver is connected.
- Consult the dealer or an experienced radio/TV technician for help.

---

**Caution** Changes or modifications not expressly approved by the party responsible for compliance could void the user's authority to operate the unit.

---

## CE Statement



Operation is subject to the following two conditions: (1) this device may not cause harmful interference, and (2) this device must accept any interference received, including interference that may cause undesired operation. The manufacturer declares that the unit supplied with this guide is compliant with the essential protection requirements of EMC directive and General Product Safety Directive GPSD conforming to requirements of standards EN55022 for emission, EN 50130-4 for immunity, EN 300 and EN 328 for WIFI.

This product is IP67 rated for outdoor environments and IK10 rate for impact protection. The camera also meets regulations required to be NDAA, GSA schedule and TAA approved.

WE SECURE YOUR LIFE



# 1 Product Overview

## 1.1 Physical Characteristics

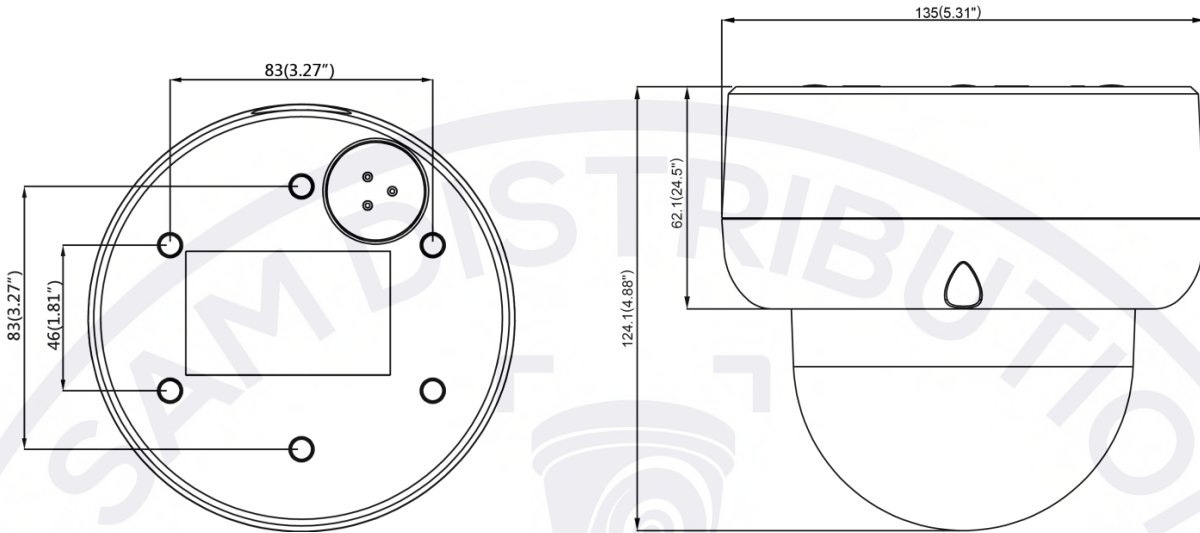

**Figure 1 - 1: Physical Dimensions**

Unit: mm (in.)

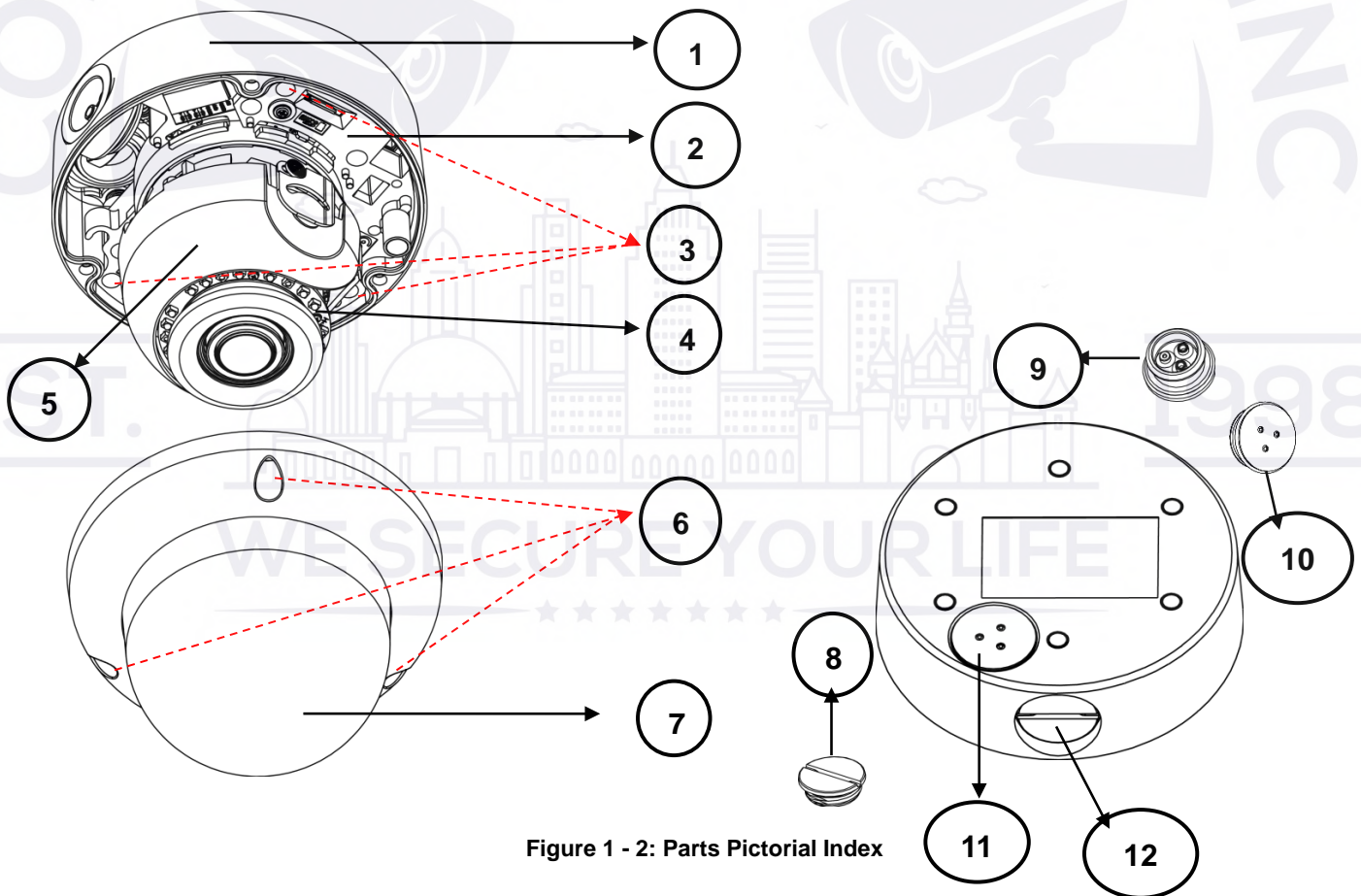

**Figure 1 - 2: Parts Pictorial Index**

No.	Name	Description
1	Camera Bottom Case	Bottom base of the camera dome.
2	Camera Module	The physical main body of the camera.
3	Screws of Camera Bottom Case (3x)	Screws for fixing camera module to the camera bottom case.
4	IR Board	The IR LED embedded board for illumination under low-light environment.
5	Inner Liner	The inner adjustable liner to cover for camera lens assembly (for aesthetic purposes).
6	Screws of Camera Housing (3x)	Screws for fixing camera housing to the camera bottom case.
7	Camera Housing	The top cover of the camera.
8	Conduit Hole Plug Cover	To close the unused conduit hole (delivered pre-installed).
9	<b>Black</b> Conduit Hole Rubber Grommet	For water and dust ingress protection; <i>must</i> be used when the cables are run directly into the Side Conduit Hole to prevent water leakage issue. Use plug 8 on the bottom hole.
10	<b>Gray</b> Conduit Hole Rubber Grommet	For water and dust ingress protection; <i>must</i> be used when the cables are run directly into the Bottom Conduit Hole to prevent water leakage issue. Use plug 8 on the on the side hole.
11	Bottom Conduit Hole	The bottom hole for cable entry
12	Side Conduit Hole	The side hole for cable entry.

**Table 1 - 1: Parts Pictorial Index Description**

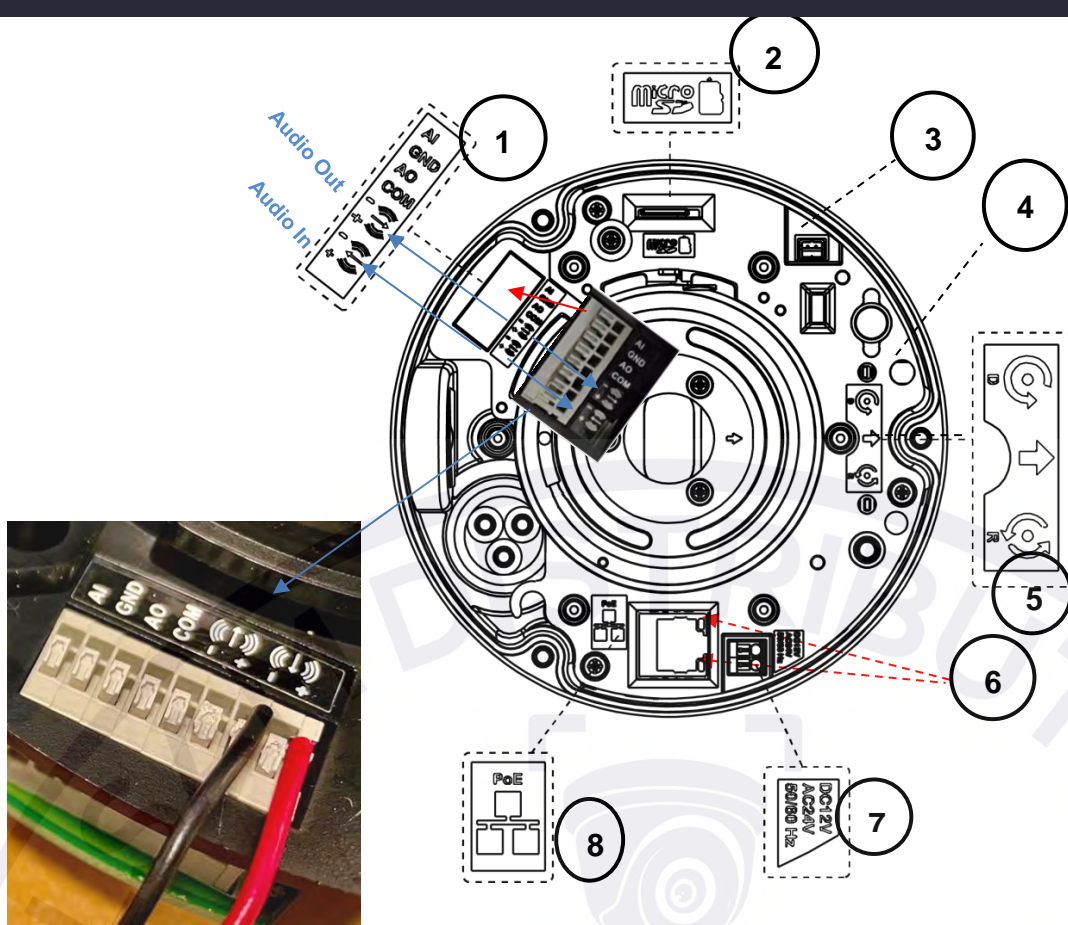

Typical Audio Input Wiring

Figure 1 - 3: Internal Interface Pictorial Index

EST.



1998

WE SECURE YOUR LIFE  
★★★★★★

No.	Name	Description
1	DI/DO Port	<p>DI/DO (Digital Input/Output) ports are equipped for external devices, e.g., smoke detector, siren, microphone.</p> <ul style="list-style-type: none"> <li>• <b>Alarm In:</b> Via "AI" and "GND" ports; connect to external device that can trigger alarm input signals.</li> <li>• <b>Alarm Out:</b> Via "AO" and "COM" ports; connect to external device to be triggered through alarm output signals.</li> <li>• <b>Audio Out:</b> Via "+" and "Ⓘ" ports; connect to device such as speaker to transmit sound for camera.</li> <li>• <b>Audio In:</b> Via "+" and "Ⓜ" ports; connect to external device such as microphone that receives sound for camera.</li> </ul>
2	Micro SD card slot	Insert a micro SD card (customer supplied) into the slot for recording and file storage
3	Video Output	For analog video output (5 MP/8 MP models only).
4	Status LED	<p>Solid Red</p> <ul style="list-style-type: none"> <li>- Solid Red to Flashing Green if boot up is normal.</li> <li>- Remains Solid Red if an error occurs.</li> <li>- Turns off 3 minutes after a successful boot.</li> </ul>
		<p>Flashing Amber</p> <p>Indicates firmware upgrade is running.</p>
5	Default & Reset Button	<p><b>Default (D):</b> Press the button for 6 seconds to restore the camera's settings to factory default.</p>
		<p><b>Reset (R):</b> Press the button for less than 1 second to reboot the camera.</p>
6	LED Indicators	<p>Solid Green</p> <p>Indicates a live connection is established.</p>
		<p>Flashing Orange</p> <p>Indicates data is being transmitted/received between camera and the network.</p>
7	Power Terminal	The port is used to connect with external power supply, either 12 VDC or 24 VAC.
8	RJ-45 Network Port	Connect the RJ-45 connector to this port with a PoE (Class 3) compatible network device that supplies power through the Ethernet cable.

Table 1 - 2: Internal Interface Index Description

## 2 Installation, Mounting and Connections

### 2.1 Package Contents

---

Check if all items listed below are included in the packing box.

- Dome Camera \* 1
- Plastic Anchor \* 4
- Pan Head Screw (TP4) \* 4
- T20 Security Torx Bit \* 1
- Mounting Template \* 1
- Conduit Hole Rubber Grommet \* 2
- Conduit Hole Plug Cover \* 1
- RJ-45 Jumper Cable and Waterproof Tape \* 1 of each
- Video Out BNC Cable \* 1 (5 MP/8 MP models only)
- Desiccant \* 1

### 2.2 Installation

---

The following tools may be helpful to complete the installation:

- Drill
- Screwdrivers
- Wire cutters

#### 2.2.1 Checking Appearance

When unpacking, check to see if there is any visible damage to the appearance of the camera and its accessories. The protective materials used for the packaging should protect the camera from most accidents during shipment. Remove the protective materials from the camera after every item is properly checked in accordance with the list in **Package Contents**.

## 2.2.2 Disassembling the Camera

Refer to the steps and figure below for correct disassembly order of the camera.

1. Loosen the 3 screws of camera housing turning counterclockwise using the T20 security torx bit.
2. Gently pull the camera housing downward to separate it from the camera body.

**DO NOT** remove the camera from the camera bottom case during installation. The camera has been designed to allow for installation without removing camera module from back box.

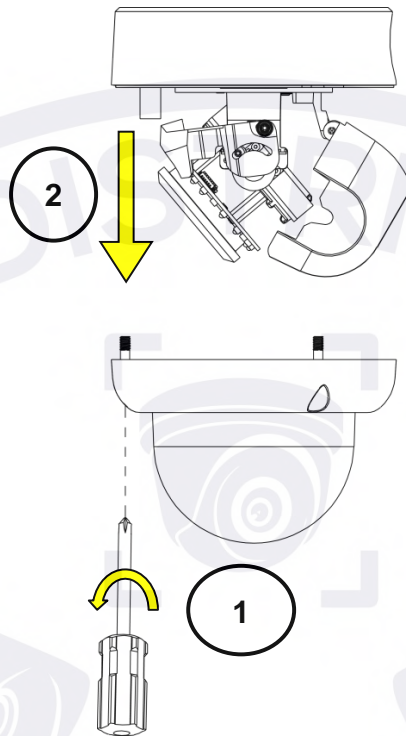

Figure 2 - 1: Disassembling the Camera

### 2.2.3 Installing the Desiccant

1. Lift to open the inner liner.
2. Secure the desiccant (via the sticker that is attached to the desiccant) on the inside part of inner liner as shown in the following figure.

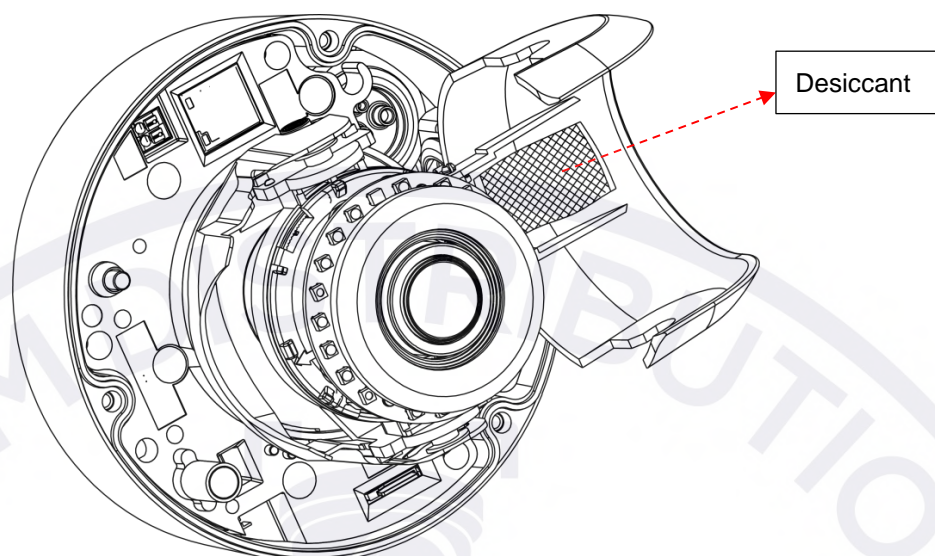

Figure 2 - 2: Installing the Desiccant

3. Return the inner liner back to its default position after desiccant installation.

### 2.2.4 Connecting the Cables

The I/O interfaces are on the front of the camera module. Make the appropriate cable connections.

1. Based on your needs, connect the power cable to the power port via one of the following 3 options.
  - **24 VAC:** Connect a power cable that supplies 24 VAC power source to the power terminal.
  - **12 VDC:** Connect a power cable that supplies 12 VDC power source to the power terminal.

**NOTE:** Be sure the polarities match when using 12 VDC power source.

- **PoE (Class 3):** Connect an Ethernet cable terminated with a **short-bodied** RJ-45 connector to the PoE RJ-45 port for both power supply and network connectivity purposes simultaneously.
2. Connect BNC cable for video output, if required. BNC cable is used to connect to the video input terminal of a monitor, switcher, etc. (to be terminated with 75 ohm impedance). Do NOT pass the BNC cable through the supplied rubber grommet, as that will damage the waterproof protection. Refer to step 8 below for how to properly use the supplied grommet.

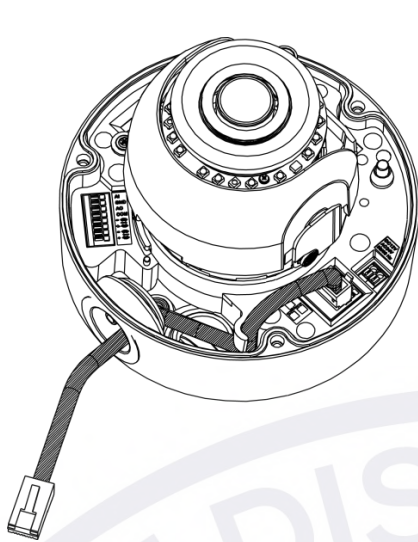

Figure 2 - 3: Connecting Ethernet Cable

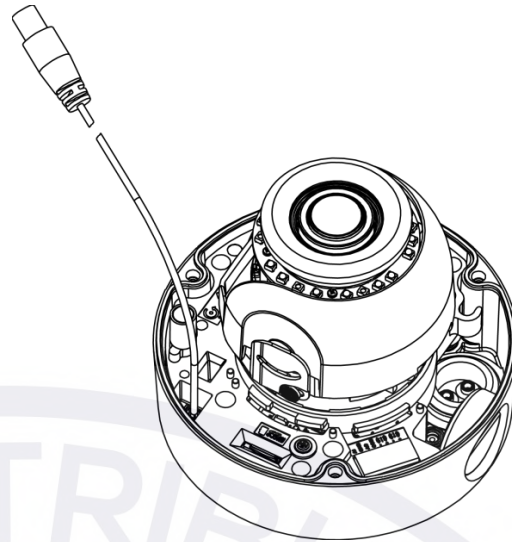

Figure 2 - 4: Connecting BNC Cable

3. Insert audio in/out cables and alarm in/out cables to the corresponding terminals of the camera, if required.

**NOTE:** It is recommended to connect external microphones to ground (GND) on the digital I/O connector.

4. Refer to **Figure 1 - 3: Internal Interface Pictorial Index** for details on I/O interface.
5. If using the supplied rubber grommet (recommended), puncture a round hole(s) in the grommet that is smaller than the diameter of the cable that will be passed through the grommet. Feed an unterminated cable through the hole in the grommet. Terminate the cable with the appropriate connector. Refer to Figure 2-5.

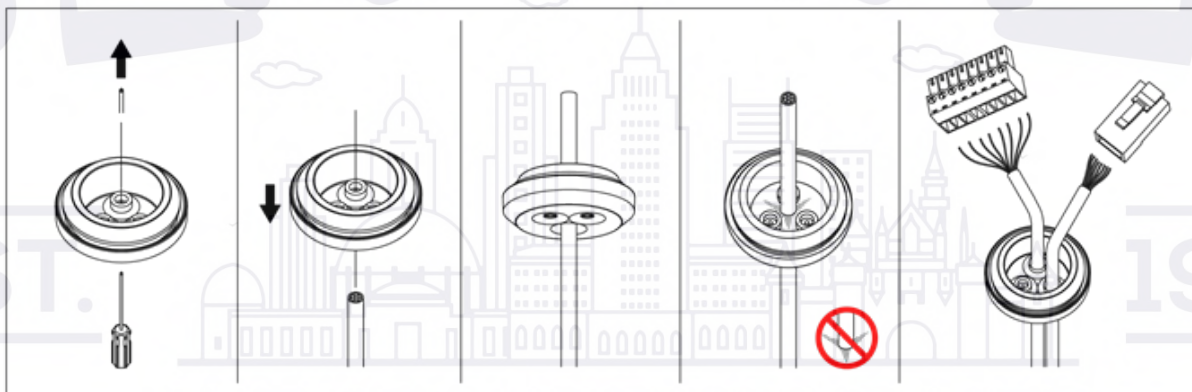

Figure 2 - 5: Using Rubber Grommet

For installations using Cat6 cable or pre-terminated cables with rubber jackets, a jumper cable accessory is supplied to provide easy installation for the increased size of the cable; waterproof tape is also included to maintain the watertight integrity of the installation. Refer to the instruction sheet with the jumper cable for details on using it.

## 2.2.5 Mounting the Camera

- Use the mounting template to prepare a mounting area for surface mounting.
  1. Place the supplied mounting template on a mounting surface. Drill 6 mm (0.2") outer holes at the T1 (double gang box) or T2 (single gang box) template positions on the mounting surface. Then insert 2 or 4 supplied plastic anchors into the holes.
  2. If feeding wiring from the hole on the rear of the camera bottom case, create a circular opening corresponding to the "Bottom conduit hole" on the mounting template on the mounting surface.
  3. If feeding wiring from the side of the camera bottom case, it is not necessary to drill a hole on the mounting surface. The "Side conduit hole" indication on the mounting template is for user to identify while mounting.

**NOTE:** Properly close the unused hole with the supplied conduit hole plug. For example, block the side conduit hole with the plug when using the bottom conduit hole for cable entry and vice versa.

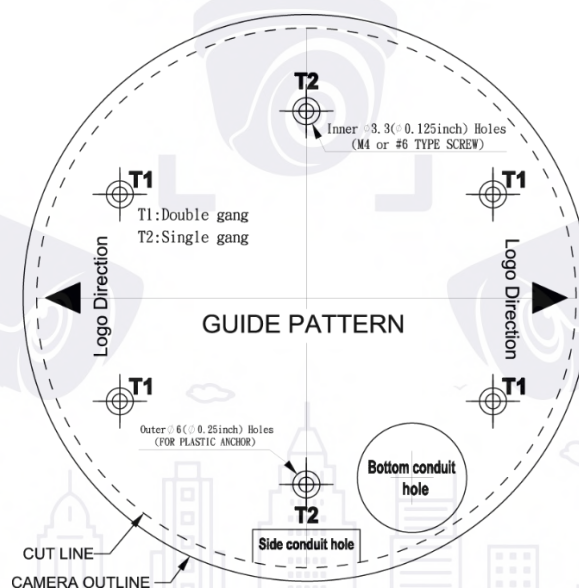

**Figure 2 - 6: Mounting Template for Surface Mount**

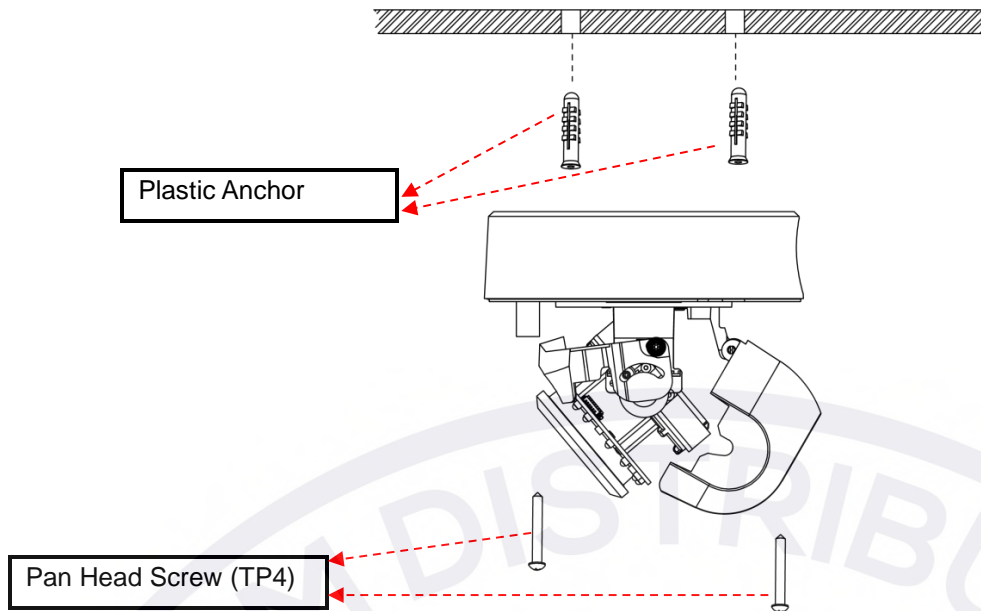

**Figure 2 - 7: Wall or Ceiling Surface Mount**

4. Based on your installation requirements, use the bottom or side conduit hole on the camera bottom case for cable entry and feed the cables through the camera bottom case first. Then mount the camera bottom case on a wall surface by tightly securing 4 TP4 screws (supplied) into the inserted plastic anchors. Note: Unless you are mounting directly to a flat surface, do NOT remove the small black plugs from the mounting hole; this maintains the waterproof protection. If you are mounting directly to a flat surface, remove the rubber plugs.
  - a. Alternatively, the camera bottom case can be fastened directly to a single gang or double gang electrical box (fasteners not provided).
  - b. The mounting height above ground level should be more than 9.8 ft (3 m) for wall mount height.

EST. 1998

WE SECURE YOUR LIFE

★★★★★★

## 2.2.6 Positioning the Camera

- **Pan Adjustment (A)**

Rotate the lens camera assembly to the desired field of view. Note that the camera lens should not be rotated further than the point where the side conduit hole of the camera bottom case is located.

- **Horizontal Rotation (B)**

Rotate the lens camera assembly in the camera module; do not turn assembly more than 355°, as this may cause the internal cables to be twisted, disconnected or broken. In addition, pay attention to the location upon which the light sensor (1) is located, since excessive rotation, in certain cases, results in obstruction to light sensor by the IR reflection shield (2). Check the Orientation section in *User's Manual* when 180° above rotation is necessary, for swift orientation adjustment.

- **Tilt Adjustment (C)**

Lift to open the inner liner and tilt the camera lens to the desired angle. Restore the inner liner back to its default position after adjustment.

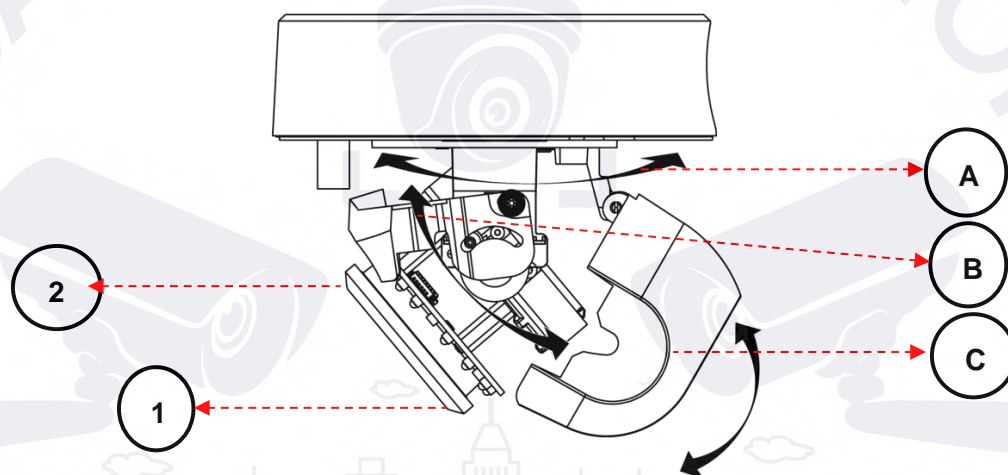

**Figure 2 - 8: Positioning the Camera**

**Caution**

Limitation for three axes position:

- Pan range: 0° ~ 370°
- Rotation range: 0° ~ 355°
- Tilt range: 15° ~ 90°

## 2.2.6 Reassembling the Camera

Assemble the camera housing with the camera bottom base, both of which have red dots for indicating alignment; then fasten the 3 screws of the lower dome with the T20 security torx bit to complete the installation.

Note: To avoid moving the tilt position, take care to angle the lower dome below the camera module when installing the lower dome.

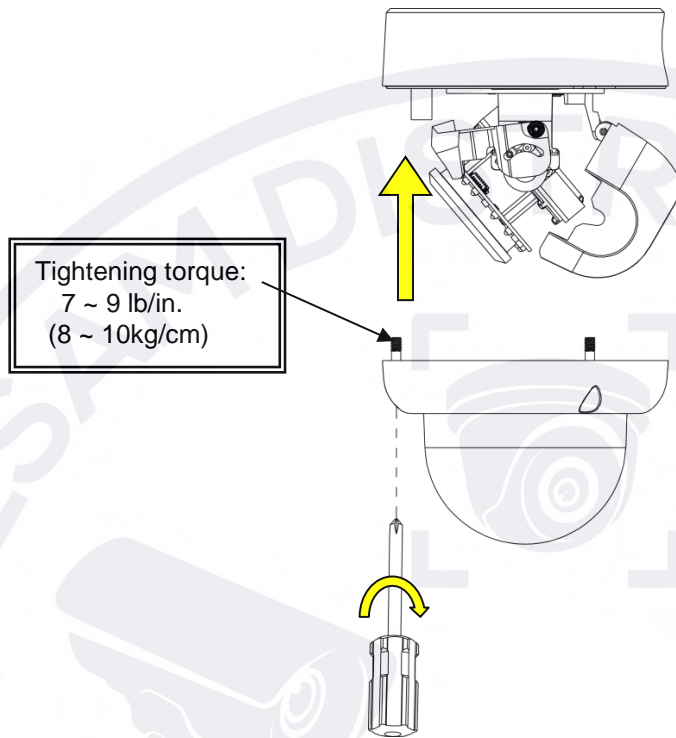

Figure 2 - 9: Assembling and Completing Camera Mounting

## 2.2.7 Lower Dome Defog

A Defog function, which heats up the camera to overcome certain extreme weather conditions (e.g., snow or frost) that may harm the operation of camera, is embedded within this vandal dome camera. This defog heater ring is On between 140°~ -40 ° F (60°~ -40 ° C). To prevent installers from getting a burn injury, the defog heating function is not activated when the lower dome is detached from the camera module (as shown in the following figure).

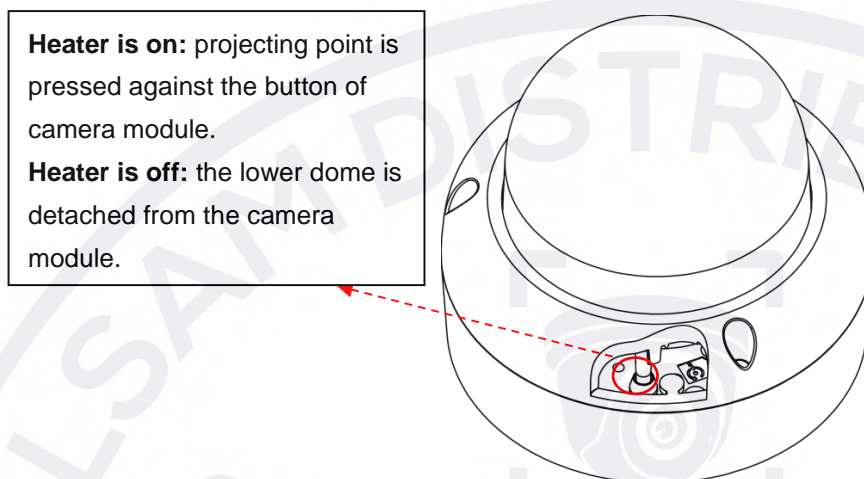

Figure 2 - 10: Lower Dome Defog

## 3 Connection

### 3.1 Network

The camera, which is equipped with Ethernet RJ-45 network interface, can deliver live view image in real time via both Internet and Intranet. Review the topology drawings shown below.

### 3.2 System Requirements

The table below lists the minimum requirements to implement and operate the camera. It is recommended not to use any hardware/software component below these requirements for proper performance.

**Table 3 - 1: System Requirements**

System Hardware	
CPU	i5-2430M CPU@ 2.40GHZ
RAM	6 GB or above
Display	NVIDIA GeForce 6 Series or ATI Mobility Radeon 9500
System Software	
Operating System	Windows 7 SP1, Windows 8, Windows 10
Browser	Mozilla Firefox, Chrome, Safari, Microsoft Edge
Unit	
Power Supply	12 VDC/24 VAC/PoE (IEEE 802.3af Class 3)
Networking	
Wired*	10/100BASE-T Ethernet (RJ-45 connector)

\*A switch is required for surveillance on multiple cameras.

**Note** All the installation and operations should comply with your local electricity safety regulations.

**Caution** When using PoE, this camera is to be connected only to PoE networks without routing to any heterogeneous devices. A heterogeneous network is a network connecting computers and other devices where the operating systems and protocols have significant differences.

## 3.3 Connecting Process

### 3.3.1 Accessing the Camera

The camera can be accessed directly from its web page or using Vicon's [PRONTO Device Manager](#), which can be found on Vicon's website. Note that when accessing the camera for the first time, a message will display to reset the password.

Since this is a network-based camera, an IP address must be assigned. The camera's default IP address is obtained automatically through a DHCP server in your network; be sure to enable DHCP in "Network Settings." If DHCP is not available, the camera will use APIPA (link-local address); IPv4 link-local addresses are assigned from address block 169.254.0.0/16 (169.254.0.0 through 169.254.255.255).

### 3.3.2 Connecting from a Computer

#### Connecting from a computer

1. Make sure the camera and your computer are in the same subnet.
2. Check whether the network available between the camera and the computer by executing ping the default IP address. To do this, simply start a command prompt (Windows: from the "Start Menu", select "Program". Then select "Accessories" and choose "Command Prompt"), and type "Ping" and then type in your IP address. If the message "Reply from..." appears, it means the connection is available.
3. Start a browser, e.g., Internet Explorer, and enter IP address. A login window as shown below should pop up. In the window, enter the default user name: **ADMIN**; it is required to change the password when you login for the first time for added security, which requires at least 8 characters including 1 uppercase letter, 1 special character, alphanumeric characters to log in.
4. Further administration of the unit can be found in "User Manual."

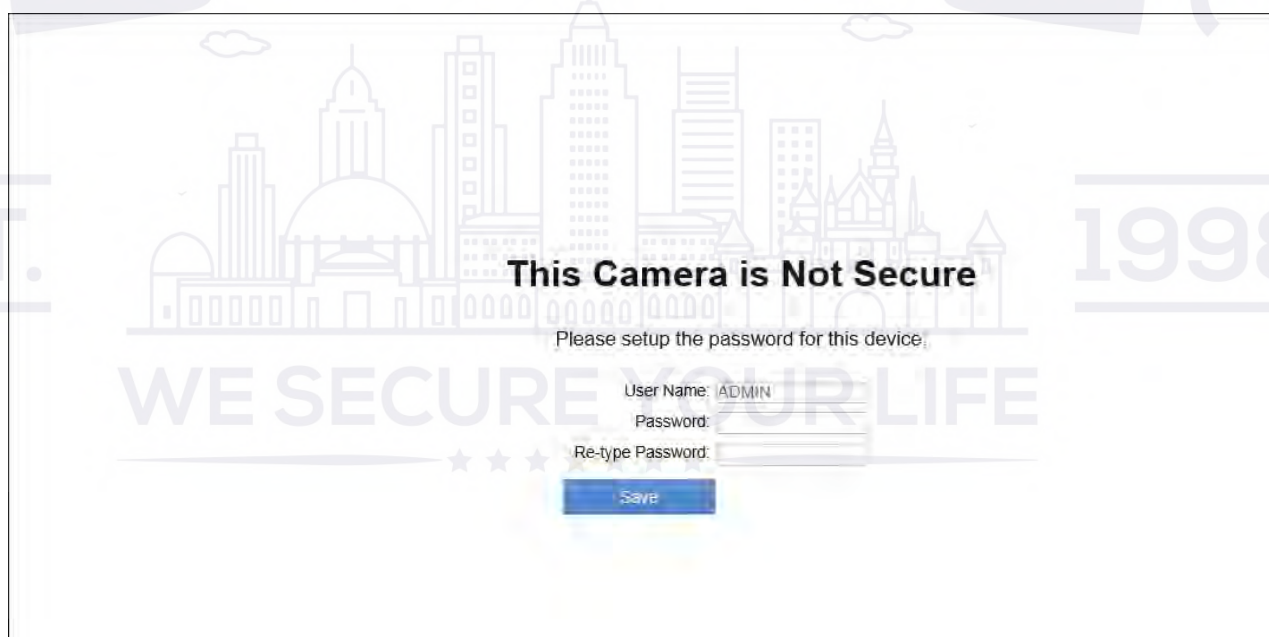

Figure 3 - 1: Login Window

### 3.4 PRONTO Device Manager

PRONTO is Vicon's device manager (Discovery tool) that can be used to discover all Vicon cameras on a system. The complete [User Manual](#) can be found on Vicon's website.

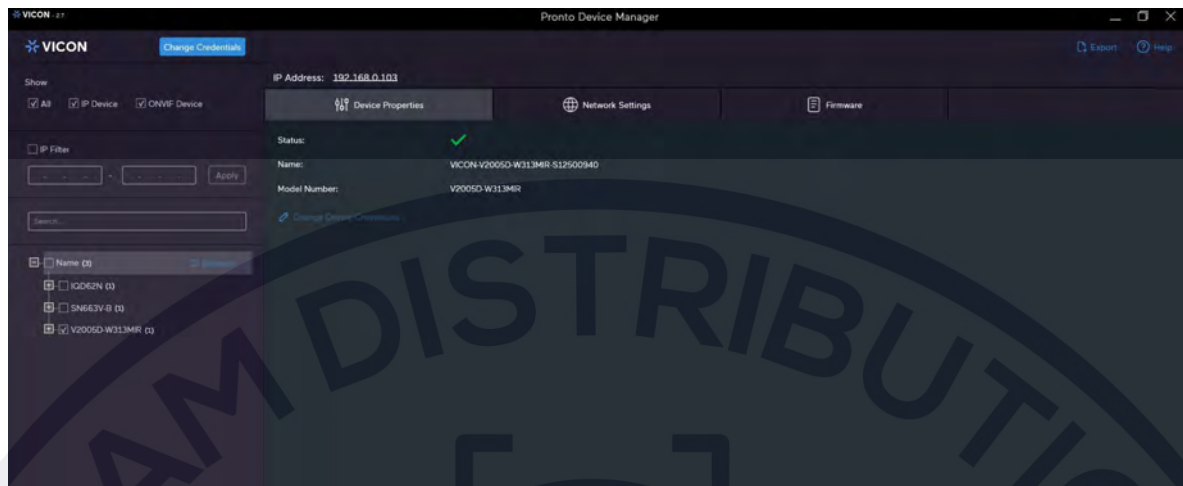

Figure 3 - 2: PRONTO Interface

- Upon startup of the PRONTO Device Manager, the tool's auto-discovery function generates a list of the discovered cameras on the network in a resource list.
- There are a variety of filtering options, including filter by All Devices/IP Device/ONVIF Device; IP range or text.
- There are tabs for Device Properties, Network Settings and Firmware.