

HIKVISION

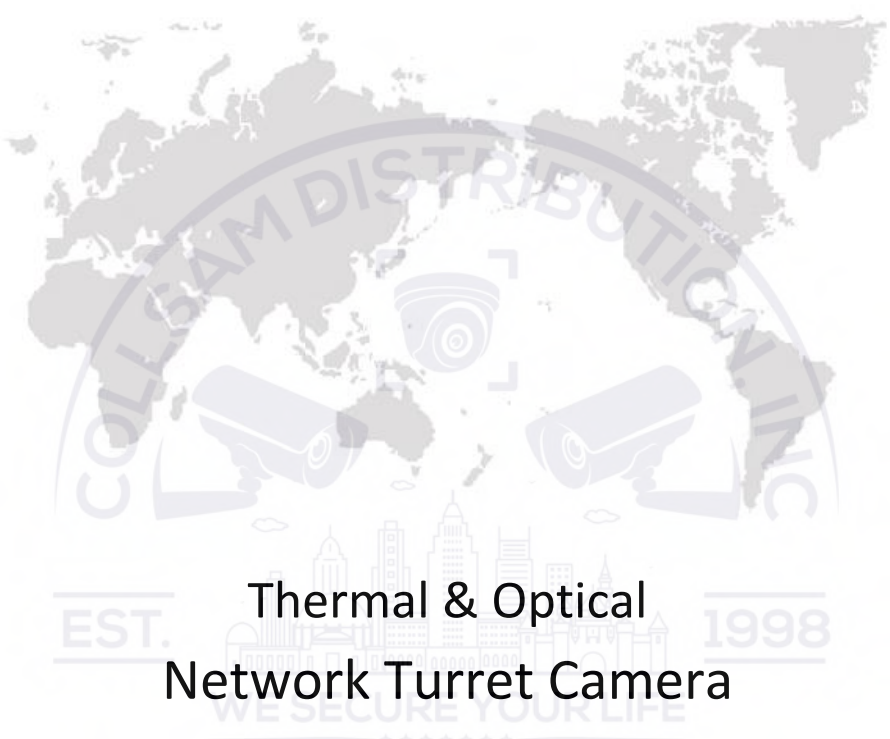

Thermal & Optical Network Turret Camera

Quick Start Guide

COPYRIGHT ©2019 Hangzhou Hikvision Digital Technology Co., Ltd.

Sales@collsam.com [HTTPS://COLLSAM.COM](https://collsam.com)Support@collsam.com
(951)282-8707 (213)210-6744
Images May Not Reflect the Actual Product
Design and specifications are subject to change without notice.

Quick Start Guide

COPYRIGHT ©2019 Hangzhou Hikvision Digital Technology Co., Ltd.

ALL RIGHTS RESERVED.

Any and all information, including, among others, wordings, pictures, graphs are the properties of Hangzhou Hikvision Digital Technology Co., Ltd. or its subsidiaries (hereinafter referred to be “Hikvision”). This user manual (hereinafter referred to be “the Manual”) cannot be reproduced, changed, translated, or distributed, partially or wholly, by any means, without the prior written permission of Hikvision. Unless otherwise stipulated, Hikvision does not make any warranties, guarantees or representations, express or implied, regarding to the Manual.

About this Manual

This Manual is applicable to **Thermal & Optical Network Turret Camera**.

The Manual includes instructions for using and managing the product. Pictures, charts, images and all other information hereinafter are for description and explanation only. The information contained in the Manual is subject to change, without notice, due to firmware updates or other reasons. Please find the latest version in the company website (<http://overseas.hikvision.com/en/>).

Please use this user manual under the guidance of professionals.

Trademarks Acknowledgement

HIKVISION and other Hikvision’s trademarks and logos are the properties of Hikvision in various jurisdictions. Other trademarks and logos mentioned below are the properties of their respective owners.

Legal Disclaimer

TO THE MAXIMUM EXTENT PERMITTED BY APPLICABLE LAW, THE PRODUCT DESCRIBED, WITH ITS HARDWARE, SOFTWARE AND FIRMWARE, IS PROVIDED “AS IS”, WITH ALL FAULTS AND ERRORS, AND HIKVISION MAKES NO WARRANTIES, EXPRESS OR IMPLIED, INCLUDING WITHOUT LIMITATION, MERCHANTABILITY, SATISFACTORY QUALITY, FITNESS FOR A PARTICULAR PURPOSE, AND NON-INFRINGEMENT OF THIRD PARTY. IN NO EVENT WILL HIKVISION, ITS DIRECTORS, OFFICERS, EMPLOYEES, OR AGENTS BE LIABLE TO YOU FOR ANY SPECIAL, CONSEQUENTIAL, INCIDENTAL, OR INDIRECT DAMAGES, INCLUDING, AMONG OTHERS, DAMAGES FOR LOSS OF BUSINESS PROFITS, BUSINESS INTERRUPTION, OR LOSS OF DATA OR DOCUMENTATION, IN CONNECTION WITH THE USE OF THIS PRODUCT, EVEN IF HIKVISION HAS BEEN ADVISED OF THE POSSIBILITY OF SUCH DAMAGES.

REGARDING TO THE PRODUCT WITH INTERNET ACCESS, THE USE OF PRODUCT SHALL BE WHOLLY AT YOUR OWN RISKS. HIKVISION SHALL NOT TAKE ANY RESPONSIBILITIES FOR

ABNORMAL OPERATION, PRIVACY LEAKAGE OR OTHER DAMAGES RESULTING FROM CYBER ATTACK, HACKER ATTACK, VIRUS INSPECTION, OR OTHER INTERNET SECURITY RISKS; HOWEVER, HIKVISION WILL PROVIDE TIMELY TECHNICAL SUPPORT IF REQUIRED.

SURVEILLANCE LAWS VARY BY JURISDICTION. PLEASE CHECK ALL RELEVANT LAWS IN YOUR JURISDICTION BEFORE USING THIS PRODUCT IN ORDER TO ENSURE THAT YOUR USE CONFORMS THE APPLICABLE LAW. HIKVISION SHALL NOT BE LIABLE IN THE EVENT THAT THIS PRODUCT IS USED WITH ILLEGITIMATE PURPOSES.

IN THE EVENT OF ANY CONFLICTS BETWEEN THIS MANUAL AND THE APPLICABLE LAW, THE LATER PREVAILS.

Regulatory Information

FCC Information

FCC compliance: This equipment has been tested and found to comply with the limits for a Class A digital device, pursuant to part 15 of the FCC Rules. These limits are designed to provide reasonable protection against harmful interference when the equipment is operated in a commercial environment. This equipment generates, uses, and can radiate radio frequency energy and, if not installed and used in accordance with the instruction manual, may cause harmful interference to radio communications. Operation of this equipment in a residential area is likely to cause harmful interference in which case the user will be required to correct the interference at his own expense.

FCC Conditions

This device complies with part 15 of the FCC Rules. Operation is subject to the following two conditions:

1. This device may not cause harmful interference.
2. This device must accept any interference received, including interference that may cause undesired operation

EU Conformity Statement



This product and - if applicable - the supplied accessories too are marked with "CE" and comply therefore with the applicable harmonized European standards listed under the EMC Directive 2014/30/EU, the RoHS Directive

2011/65/EU.



2012/19/EU (WEEE directive): Products marked with this symbol cannot be disposed of as unsorted municipal waste in the European Union. For proper recycling, return this product to your local supplier upon the purchase of equivalent new equipment, or dispose of it at designated collection points. For more information see: www.recyclethis.info.



2006/66/EC (battery directive): This product contains a battery that cannot be disposed of as unsorted municipal waste in the European Union. See the product documentation for specific battery information. The battery is marked with this symbol, which may include lettering to indicate cadmium (Cd), lead (Pb), or mercury (Hg). For proper recycling, return the battery to

your supplier or to a designated collection point. For more information see: www.recyclethis.info.

Industry Canada ICES-003 Compliance

This device meets the CAN ICES-3 (A)/NMB-3(A) standards requirements.



Safety Instruction

These instructions are intended to ensure that user can use the product correctly to avoid danger or property loss.

The precaution measure is divided into **Warnings** and **Cautions**:

Warnings: Neglecting any of the warnings may cause serious injury or death.

Cautions: Neglecting any of the cautions may cause injury or equipment damage.

	
Warnings Follow these safeguards to prevent serious injury or death.	Cautions Follow these precautions to prevent potential injury or material damage.



Warnings

- The device should be used in compliance with local laws and electrical safety regulations. Refer to the appropriate documentation for detailed information.
- The input voltage should conform to IEC60950-1 standard: SELV (Safety Extra Low Voltage) and the Limited Power Source (12 VDC). Refer to the appropriate documentation for detailed information.
- DO NOT connect multiple devices to one power adapter, to avoid over-heating or fire hazards caused by overload.
- Make sure the plug is properly connected to the power socket.
- If smoke, odor, or noise arises from the device, immediately turn off the power, unplug the power cable, and contact the service center.
- The installer and user are responsible for password and security configuration and its settings.
- Both internal and external grounds should be connected properly. (The cross section area of the grounding wire must be no less than 4 mm², and no less than that of the phase connector).



Cautions

- Do not drop the device or subject it to physical shock.
- Wipe the device gently with a clean cloth and a small quantity of ethanol, if necessary.
- Do not aim the lens at the sun or any other bright light.

Thermal & Optical Network Turret Camera Quick Start Guide

- When any laser equipment is in use, make sure that the device lens is not exposed to the laser beam, or it may burn out.
- Do not place the camera in extremely hot, cold (the working temperature shall be -40 °C to 65 °C), dusty or damp locations, and do not expose it to high electromagnetic radiation.
- Place the device in a dry and well-ventilated environment.
- Keep non-waterproof devices away from liquids.
- Keep the device in original or similar packaging while transporting it.
- A few device components (e.g., electrolytic capacitor) require regular replacement. The average lifespan varies, so periodic checking is recommended. Contact your dealer for details.
- Improper use or replacement of the battery may result in explosion hazard. Replace with the same or equivalent type only. Dispose of used batteries in conformance with the instructions provided by the battery manufacturer.
- Never attempt to disassemble the device.

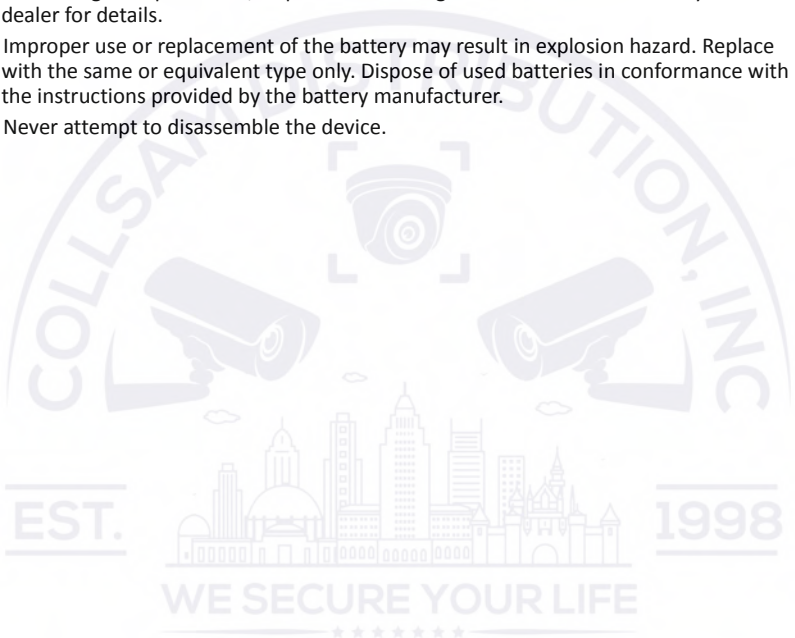

0505201090705

v

Table of Contents

1 Preparation	1
2 Appearance Description	2
2.1 Type I Turret Camera Appearance	2
2.2 Type II Turret Camera Appearance	2
2.3 Cable Descriptions	3
2.4 Alarm In/Out Connections	3
3 Install the Turret Camera	4
3.1 Monitor Distance Range	4
3.2 Install Memory Card	5
3.3 Install Turret Camera	5
3.4 Install Network Cable Water-proof Jacket	8
3.4.1 Install Network Cable Waterproof Jacket	8
3.4.2 Waterproof Other Cables	9
4 Set the System over the LAN	10
4.1 Wiring	10
4.2 Activate the System	10
4.2.1 Activation via Web Browser	10
4.2.2 Activation via SADP Software	11
4.3 Modify the IP Address	12
5 Operate via Web browser	14
5.1 Access the System	14
5.2 Live View Page	15
6 Appendix	17
6.1 Common Material Emissivity Reference	17
6.2 Frequently Asked Questions (FAQ)	18
6.2.1 Device Running Error	18
6.2.2 Device Upgrading	18
6.2.3 Others	18

1 Preparation

Basic Requirement

- All the electronic operation should be strictly compliance with the electrical safety regulations, fire prevention regulations and other related regulations in your local region.
- Check the package contents and make sure that the device in the package is in good condition and all the assembly parts are included.
- Use the system according to the working environment requirement.

Check Installing Environment

- Be sure that there is enough space to install the Turret Camera and accessories.
- Make sure that the wall is strong enough to withstand at least 8 times the weight of the system and the mount.

Prepare Cables

- According to the actual network bandwidth, the Cat5 (in 100M) or Cat6 (100M above) is needed.
- When the Turret Camera uses standard 12V DC power supply, the power cable should be American wire gauge 18 or above. The formula of the cross-section S (mm²) and the maximum transmission distance L (m) of the bare wire is $L=50*S$.
- Choose the video cable according to the transmission length. The video should meet the least demands as: 75Ω resistance; 100% copper core conducting wire; 95% weaving copper shield.

Prepare Tools

Before installation, please prepare the tools needed, such as the expansion screws, electric hammer, electric drill, wrench, screwdriver, electroprobe and network cable.

Original Packaging

When you unpack the Turret Camera, please keep the original package properly, in case of returning or repairing the Turret Camera, you can pack the Turret Camera with the package.

Note: The user should be responsible for any damage caused when transporting with unoriginal package.

2 Appearance Description

There are two types of thermal network turret cameras. Here are the overviews of Type I camera and Type II camera.

2.1 Type I Turret Camera Appearance

Refer to the following figure for type I thermal turret camera overview.

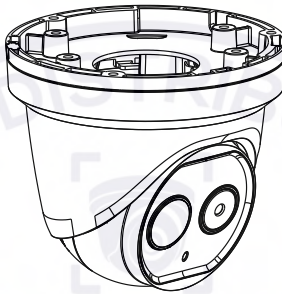

Figure 2-1 Type I Thermal Turret Camera Overview

2.2 Type II Turret Camera Appearance

Refer to the following figure for type II thermal turret camera overview.

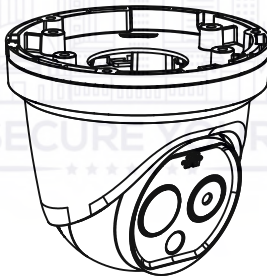

Figure 2-2 Type II Thermal Turret Camera Overview

2.3 Cable Descriptions

The cable interfaces of Turret Camera are shown in the figure below. The cables of RS-485, power supply, alarm inputs, alarm outputs, etc. are distinguished by different colors. Please refer to the labels attached on the cables for identification.

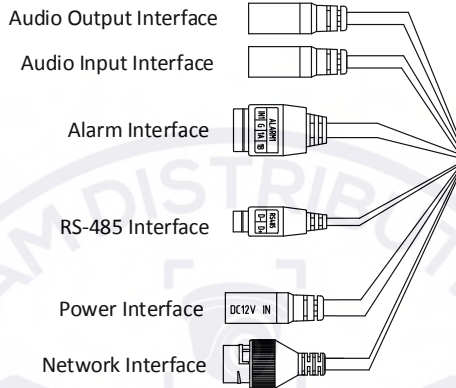

Figure 2-3 Cables of Thermal Turret Camera

2.4 Alarm In/Out Connections

This section is only for the Turret Camera with alarm in/out functions.

The Turret Camera can be connected with alarm inputs (0~5VDC) and alarm outputs. Refer to the following diagrams for alarm output:

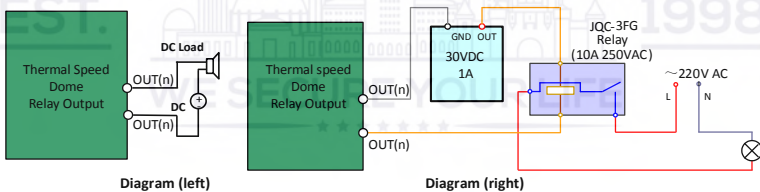

Figure 2-4 Alarm Out Connections

The alarm provides the relay output (no voltage), and the external power supply is required when it connects to the alarm device.

- For DC power supply (left diagram), the input must be no more than 30VDC, 1A.
- For AC power supply, the external relay must be used (right diagram) to prevent damages to the Turret Camera and avoid risk of electric shock.

3 Install the Turret Camera

Before you start:

1. Check the package contents and make sure that the device in the package is in good condition and all the assembly parts are included.
2. Please turn off the power of the Turret Camera before connecting the cables.

Notes:

- Do not drag the Turret Camera with its waterproof cables, or the waterproof performance is affected.
- Please remove the protective film on the Turret after the installation.
- Do not touch the bubble of the lower Turret directly. The image blurs otherwise.

3.1 Monitor Distance Range

Electric lens is adopted for the thermal channel of Turret Camera. It supports auto-focus function and remote focus function. For different lens focal length, the monitoring range is shown in the table below:

Table 3-1 Monitor Range (Pixel Interval: 17um)

Lens Focal Length/mm	1.8	3.1	6.2
MRAD	9.44	5.48	2.83
Detection Range (Vehicle)/m	162	280	559
Detection Range (Human)/m	53	91	182
Recognition Range (Vehicle)/m	41	70	140
Recognition Range (Human)/m	13	23	46
Identification Range (Vehicle)/m	20	35	70
Identification Range (Human)/m	7	11	23

Notes:

- This table is for reference only, and the actual detection range may vary according to different camera settings, mounting condition, monitor and so on.
- When the weather is fine and the atmospheric visibility is normal, the probability of detecting/recognizing/identifying target is 50%.
- The human width is presumed as 0.5m (human width cannot exceed 0.75m), the human height is presumed as 1.8m, and the vehicle width cannot exceed 2.3m.

3.2 Install Memory Card

The micro SD card of two camera models is installed in the same way. Here is an example of SD card installation for type II camera.

Steps:

1. Remove the cover on the back of the Turret Camera.

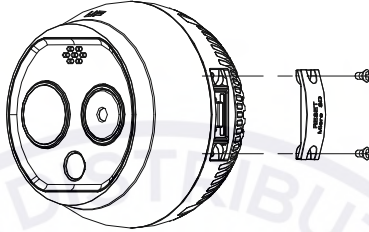

Figure 3-1 Remove the Cover

2. Insert the SD card to the SD card slot and install the cover back.

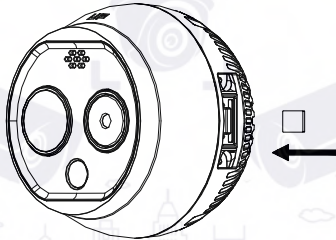

Figure 3-2 SD Card Slot

3.3 Install Turret Camera

Two types of cameras are installed in the same way. Here is an example of installation for type II camera.

Steps:

1. Drill the hole on the wall or the ceiling according to the supplied drill template

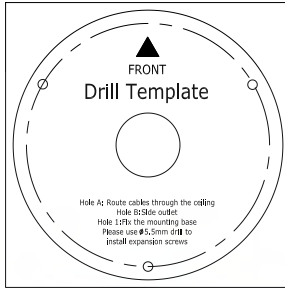

Figure 3-3 Drill Template

2. Turn the ring anticlockwise and remove it.

Note: The ring is only applicable to type II camera.

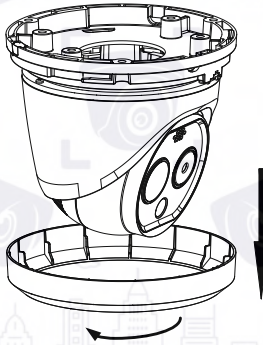

Figure 3-4 Remove the Ring

3. Loosen the screw and dismount the camera body from the base.

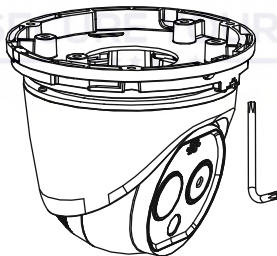

Figure 3-5 Dismount the Camera from Base

4. Mount the camera base according to the position of drill template.

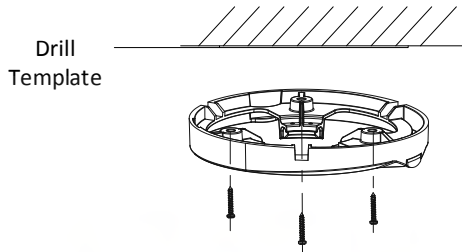

Figure 3-6 Mount the Camera Base

5. Mount the Turret body to the base. Rotate the camera body in the pan direction ($0^{\circ}\sim 360^{\circ}$) or rotate the lens in the tilt direction ($0^{\circ}\sim 80^{\circ}$) to get the desired view angle.

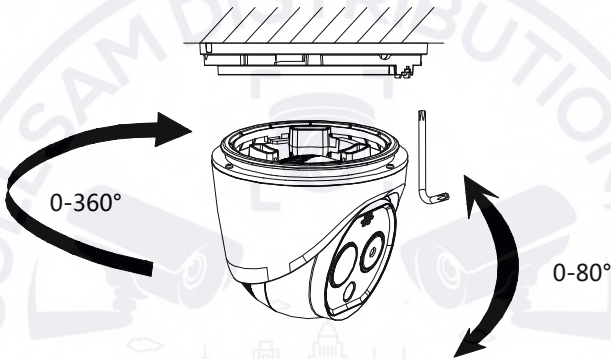

Figure 3-7 Mount the Camera Body

6. Screw the screw to fix the camera body on the camera base.

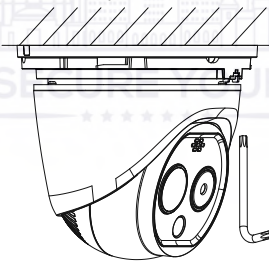

Figure 3-8 Screw the Camera

7. Mount the ring on the camera body, and turn it clockwise to fix the ring.
Note: The ring is only applicable to type II camera.

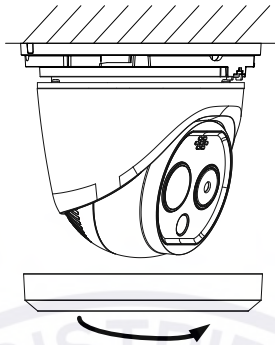

Figure 3-9 Mount the Ring

3.4 Install Network Cable Water-proof Jacket

Purpose:

If the camera is installed outdoor, you should use the waterproof accessory or tapes to waterproof the cables. Otherwise the cables might get wet or a short circuit occurs.

3.4.1 Install Network Cable Waterproof Jacket

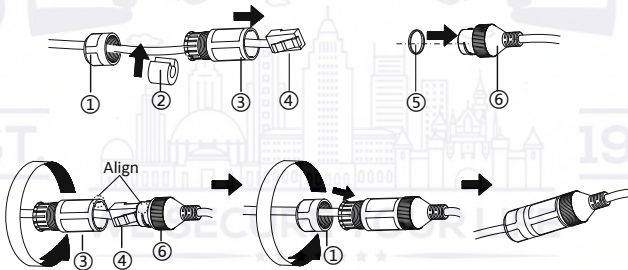

Figure 3-10 Install Waterproof Jacket

Steps:

1. Feed the network cable through ① and ③ in order.
2. Fix ② on the network cable between ① and ③.
3. Place ⑤ onto the end of ⑥, and plug the RJ45 male connector into RJ45 female connector.
4. Screw ③ to ⑥ clockwise.
5. Push ② into ③.

6. Secure ① with the ③ in clockwise direction.

3.4.2 Waterproof Other Cables

After routing and connecting the cables, use the waterproof tapes to wrap up the cables. Connected cables and spare cables both should be wrapped up as the figures below.

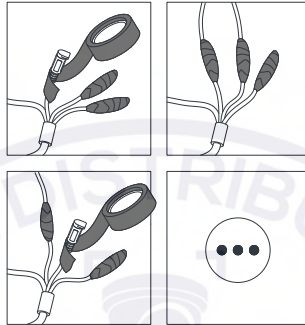
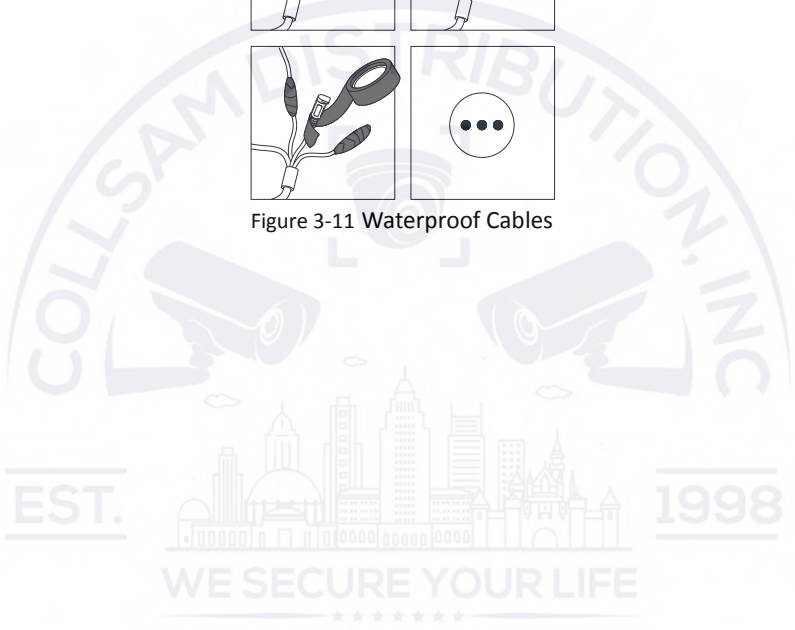

Figure 3-11 Waterproof Cables



4 Set the System over the LAN

Notes:

- You shall acknowledge that the use of the product with Internet access might be under network security risks. For avoidance of any network attacks and information leakage, please strengthen your own protection. If the product does not work properly, please contact with your dealer or the nearest service center.
- To ensure the network security of the Turret Camera, we recommend you to have the system assessed and maintained termly. You can contact us if you need such service.

4.1 Wiring

To view and configure the system via LAN (Local Area Network), you need to connect the network system in the same subnet with your PC. Then, install the SADP or client software to search and change the IP of network system.

The following figure shows the cable connection of network system.

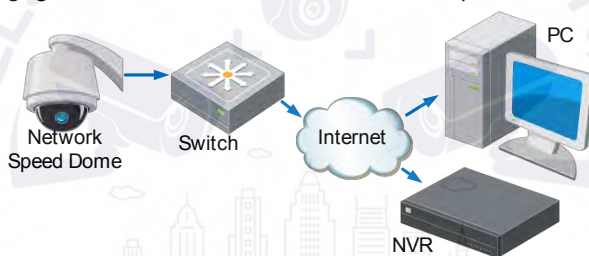

Figure 4-1 Wiring over LAN

4.2 Activate the System

Purpose:

You are required to activate the system first by setting a strong password for it before you can use the system.

Activation via Web Browser, Activation via SADP, and Activation via client software are supported. In the following sections, activation via web browser and SADP will be taken as examples. You may refer to the user manual of the system for the details of activation via client software.

4.2.1 Activation via Web Browser

Steps:

1. Power on the system, and connect the system to the network.

- Input the IP address into the address bar of the web browser, and click Enter to enter the activation interface.

Note: The default IP address of the system is 192.168.1.64.

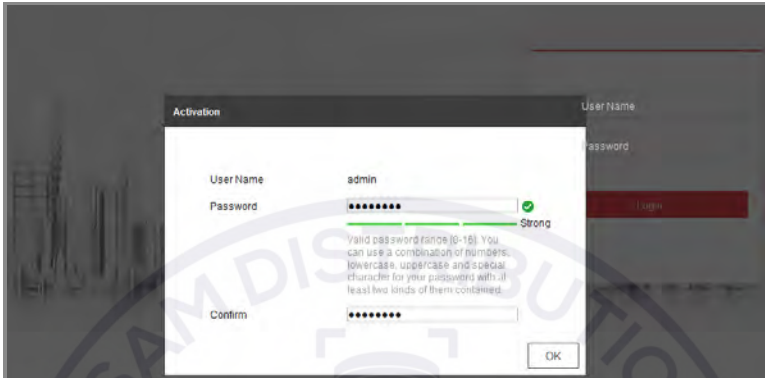

Figure 4-2 Activation Interface(Web)

- Create a password and input the password into the password field.



STRONG PASSWORD RECOMMENDED— We highly recommend you create a strong password of your own choosing (using a minimum of 8 characters, including upper case letters, lower case letters, numbers, and special characters) in order to increase the security of your product. And we recommend you reset your password regularly, especially in the high security system, resetting the password monthly or weekly can better protect your product.

- Confirm the password.
- Click **OK** to activate the system and enter the live view interface.

4.2.2 Activation via SADP Software

SADP software is used for detecting the online device, activating the device, and resetting the password.

Get the SADP software from the supplied disk or the official website, and install the SADP according to the prompts. Follow the steps to activate the system.

Steps:

- Run the SADP software to search the online devices.
- Check the device status from the device list, and select an inactive device.



Figure 4-3 SADP Interface

3. Create a password and input the password in the password field, and confirm the password.



STRONG PASSWORD RECOMMENDED– We highly recommend you create a strong password of your own choosing (using a minimum of 8 characters, including upper case letters, lower case letters, numbers, and special characters) in order to increase the security of your product. And we recommend you reset your password regularly, especially in the high security system, resetting the password monthly or weekly can better protect your product.

4. Click **OK** to save the password.

You can check whether the activation is completed on the popup window. If activation failed, please make sure that the password meets the requirement and then try again.

4.3 Modify the IP Address

Purpose:

To view and configure the system via LAN (Local Area Network), you need to connect the network system in the same subnet with your PC. Then, install the SADP software or client software to search and change the IP of network system. We will take modifying the IP Address via SADP software as an example to introduce the IP address modification.

Steps:

1. Run the SADP software.
2. Click to select an active device.

Note: Please refer to section 3.2 to activate the system if it is inactive.

3. Change the device IP address to the same subnet with your computer by either modifying the IP address manually or checking the checkbox of Enable DHCP.

Modify Network Parameters

Enable DHCP
 Enable Hik-Connect

Device Serial No.: XX-XXXXXXXX-XXXXXXXXXXXXXXXXXX

IP Address: 192.168.1.64

Port: 8000

Subnet Mask: 255.255.255.0

Gateway: 192.168.1.1

IPv6 Address: =

IPv6 Gateway: =

IPv6 Prefix Length: 0

HTTP Port: 80

Security Verification

Admin Password: _____

[Modify](#) [Forgot Password](#)

Figure 4-4 Modify the IP Address

4. Input the password and click **Save** to activate your IP address modification.



5 Operate via Web browser

5.1 Access the System

System Requirement:

Operating System: Microsoft Windows XP SP1 and above version / Vista / Win7 / Server 2003 / Server 2008 32bits

CPU: Intel Pentium IV 3.0 GHz or higher

RAM: 1G or higher

Display: 1024×768 resolution or higher

Web Browser: Internet Explorer 7.0 and above version, Apple Safari 5.02 and above version, Mozilla Firefox 5 and above version and Google Chrome8 and above version

Steps:

1. Open the web browser.
2. In the browser address bar, input the IP address of the network Turret Camera, e.g., 192.168.1.64 and press the Enter key to enter the login interface.
3. Activate the Turret Camera for the first time using, refer to the section **4.2 Activate the System.**

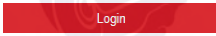
4. Input the user name and password and click .

The admin user should configure the device accounts and user/operator permissions properly. Delete the unnecessary accounts and user/operator permissions.

Note:

The device IP address gets locked if the admin user performs 7 failed password attempts (5 attempts for the user/operator).



Figure 5-1 Login Interface

5. Install the plug-in before viewing the live video and managing the network Turret Camera. Please follow the installation prompts to install the plug-in.

Note:

You may have to close the web browser to finish the installation of the plug-in.

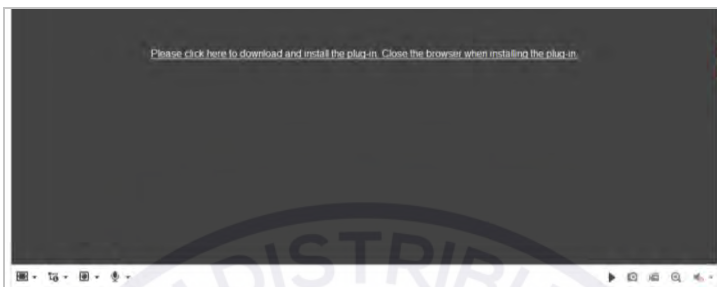

Figure 5-2 Download Plug-in

6. Reopen the web browser after the installation of the plug-in and repeat the above steps 2-4 to login.

Note:

For detailed instructions of further configuration, please refer to the user manual of network Turret Camera.

5.2 Live View Page

The live video page allows you to view live video, capture images, realize PTZ control, set/call presets and configure video parameters.

Thermal & Optical Network Turret Camera Quick Start Guide

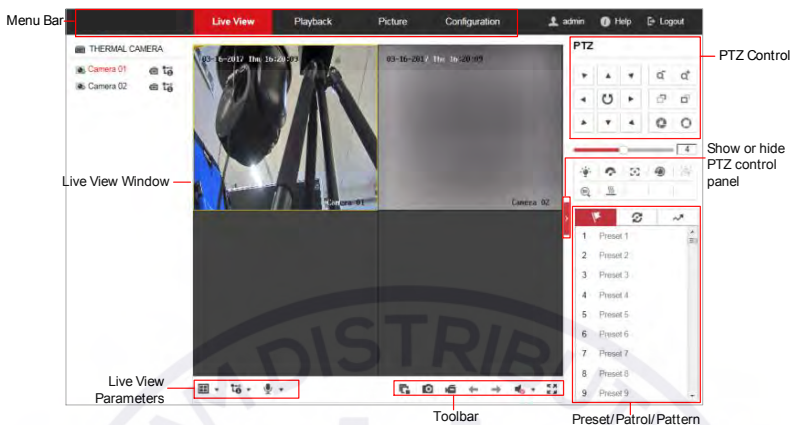



Figure 5-3 Live View Page

Menu Bar:

Click each tab to enter Live View, Playback, Picture, and Configuration page respectively.

Click  to display the help file of the Turret Camera.

Click  to logout the system.

Live View Window:

Display the live video.

Toolbar:

Operations on the live view page, e.g., live view, capture, record, audio on/off, regional exposure, regional focus, etc.

PTZ Control:

Panning, tilting, focusing and zooming actions of the Turret Camera. The lighter, wiper, one-touch focus and lens initialization control.

Preset/patrol/pattern:

Set and call the preset/patrol/pattern for the Turret Camera.

6 Appendix

6.1 Common Material Emissivity Reference

Material	Emissivity
Human Skin	0.98
PCB	0.91
Cement Concrete	0.95
Ceramics	0.92
Rubber	0.95
Paint	0.93
Wood	0.85
Asphalt	0.96
Brick	0.95
Sand	0.90
Soil	0.92
Cotton	0.98
Cardboard	0.90
White Paper	0.90
Water	0.96

6.2 Frequently Asked Questions (FAQ)

6.2.1 Device Running Error

Question:

- The device fails to start up or reboots repeatedly.
- The device constantly powers off unexpectedly when you pan/tilt the device or call preset.
- The device fails to zoom in/out or pan/tilt.

Answer:

- Examine the power supply of the Turret Camera and see whether it meets the requirements.
- Select the power supply as close as possible.
- Examine the power cord and see whether it meets the requirements.

6.2.2 Device Upgrading

Question:

Device fails to upgrade.

Answer:

- Examine if the device upgrading fails because of the poor network.
- Examine if the upgrading program matches with the device type.

6.2.3 Others

Question:

The device live view is vague.

Answer:

- Examine if you removed the protective film.
- Examine if the lens is dirty or not.
- Examine if any obstruction is nearby, e.g. spider web.

Question:

Live view fails with good network connection.

Answer:

- Examine if the IE plug-in is well installed. Change the Website Blocker settings if necessary.
- For cross-domain routing, enable the UPnP of device, or set manual mapping to port No. 80, 8000, or 554.
- Examine if the live view channel amount exceeds the upper limit.
- Examine the network bandwidth.

Question:

Focus fails when you test outdoor device in indoor situation.

Answer:

- Restore the device to default settings.
- Adjust the **Min. Focusing Distance** in **Configuration > Image > Display Settings > Focus**

